



User manual

2020/09/10

Disclaimer

CONTROLLER AND CONTROLLER SOFTWARE ARE PROVIDED TO YOU "AS IS," WITHOUT WARRANTY. THERE IS NO WARRANTY FOR THE CONTROLLER AND CONTROLLER SOFTWARE, EITHER EXPRESSED OR IMPLIED, INCLUDING, BUT NOT LIMITED TO, THE IMPLIED WARRANTIES OF MERCHANTABILITY AND FITNESS FOR A PARTICULAR PURPOSE AND NONINFRINGEMENT OF THIRD PARTY RIGHTS. THE ENTIRE RISK AS TO THE QUALITY AND PERFORMANCE OF THE CONTROLLER OR CONTROLLER SOFTWARE IS WITH YOU. SHOULD THE CONTROLLER OR CONTROLLER SOFTWARE PROVE DEFECTIVE, YOU ASSUME THE COST OF ALL NECESSARY SERVICING, REPAIR OR CORRECTION.

IN NO EVENT SHALL THE AUTHOR BE LIABLE TO YOU FOR DAMAGES, INCLUDING ANY GENERAL, SPECIAL, INCIDENTAL OR CONSEQUENTIAL DAMAGES ARISING OUT OF THE USE OR INABILITY TO USE THE CONTROLLER OR CONTROLLER SOFTWARE.

1 Introduction

1.1 Overview

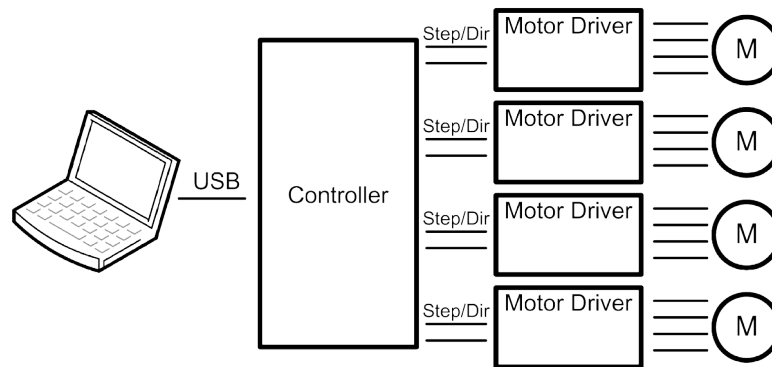

The PlanetCNC series of CNC motion controllers are link between a personal computer and motor drivers supporting step/direction control. They are compatible with most drivers. The controllers use the USB or Ethernet port, available on all modern computers and laptops. They can serve as direct replacement or upgrade for many parallel port break-out boards.

There are different models available. PlanetCNC controllers provide a complete, fully integrated software/hardware solution. The PlanetCNC TNG software is a dedicated application, designed to fully exploit the features of the purpose-built CNC hardware. It has many advanced features to assist day-to-day CNC machine operation.

1.2 Features and specifications:

- PC/Laptop running Windows 7, 8, 8.1 or Windows 10 (32-bit or 64-bit)
- PC/Laptop running Linux 64-bit OS
- iMAC with High Sierra or newer OS
- Raspberry Pi 3 and Pi4 running Raspbian
- PC/Laptop with USB (V2.x) or Ethernet port (Mk3 controller only)
- advanced motion interpolation and kinematic algorithms
- start, stop, pause and resume execution of program on your machine
- standard RS274/NGC G-code with extensions to achieve full LinuxCNC G-code compatibility
- support for user defined M-codes
- customizable M-codes (e.g.: custom M6, M3,... behavior)
- tested with DeskProto, SheetCAM, SolidCAM, MasterCAM, ArtCAM, Vectric, CamBam, MeshCAM ... generated G-code
- foam cutting 4-axes G-code supported
- lathe G-codes supported
- plasma with optional THC G-code supported
- rotational axes G-code supported
- 5-axes G-code supported
- measuring and probing supported
- spindle synchronization supported
- canned cycles supported
- transformations, different coordinate systems and offsets supported
- PWM, I2C, SPI, USART communication with external devices
- import toolpath from DXF files
- import toolpath from PLT/HPGL files
- import toolpath from image files
- import toolpath from NC-Drill (Excellon) files
- import toolpath from Gerber (RS-274X) files
- export toolpath to different formats
- simulation
- automatic and fully configurable homing procedure
- fully configurable toolchange procedure
- automatic tool length measuring

1.3 System Requirements

PlanetCNC TNG is a high performance CNC system. It is designed with flexibility in mind and it can be used for mills, routers, lathes, plasma or laser machines as well as any other machine or system where coordinated movement of servo or stepper motors is needed.

PlanetCNC TNG software works with Mk3 series of PlanetCNC motion controllers and PC running Windows 7, 8, 8.1, 10 or Linux.

For best performance of PlanetCNC TNG software, PC with 4 virtual processors(cores) CPU is recommended. However, PC's with 2 virtual processors will do just fine. Various services running in the background, antivirus software and program updates can interfere with PlanetCNC TNG performance and that is why dedicated computer is recommended.

If using USB, controller should be connected directly to computers root USB port. We recommend that you connect controller to computer root USB port via USB HUB device. Note that controller should be the only USB device connected on this HUB.

You see, all devices connected to the same HUB device share available bandwidth. Because data traffic is prioritized by the OS, it would not be uncommon if another device connected to same HUB would interfere with controller and therefore compromise the communication between controller and PC.

2 Software

2.1 Overview

PlanetCNC TNG software is designed to fully exploit the advanced features of controller hardware. At the same time the software remains user friendly. Even those new to CNC machining can employ advanced functions with ease.

Configuration options allow for maximum flexibility, integration and customization.

Simulation features are designed for fast verification of NC programs. Simulation can run automatically, under keyboard or mouse control, or by selection of individual lines in an NC program. Zoom, pan or rotate of the preview does not interrupt simulation.

The software has useful G-Code manipulation and transformation functions. G-Code can be bookmarked, copied pasted and edited. It can be shifted, scaled mirrored and rotated. Code re-mapping for foam cutter applications is available.

There are many functions to assist creation of toolpaths. A wide range of content can be directly imported or converted to NC program.

2.2 Installation

PlanetCNC TNG software is compatible with Linux (tested with Ubuntu MATE distribution), Windows 7, Windows 8, 8.1 and Windows 10(32 or 64 bit). Installation is a two-part process. Driver installation is performed, after which the main application can be installed and configured. The installation process is largely 'automatic.' In most cases it's possible to accept 'default' options.

2.2.1 Software installation on Windows

Download installation files from PlanetCNC (www.planet-cnc.com) homepage:

<https://planet-cnc.com/software/>

From *Choose your download* drop-down menu select *PlanetCNC TNG 2018 – Windows* and click *Download*. Double click on downloaded *PlanetCNC_Install.exe* file to begin with installation.

Setup-PlanetCNC dialogue will be displayed:

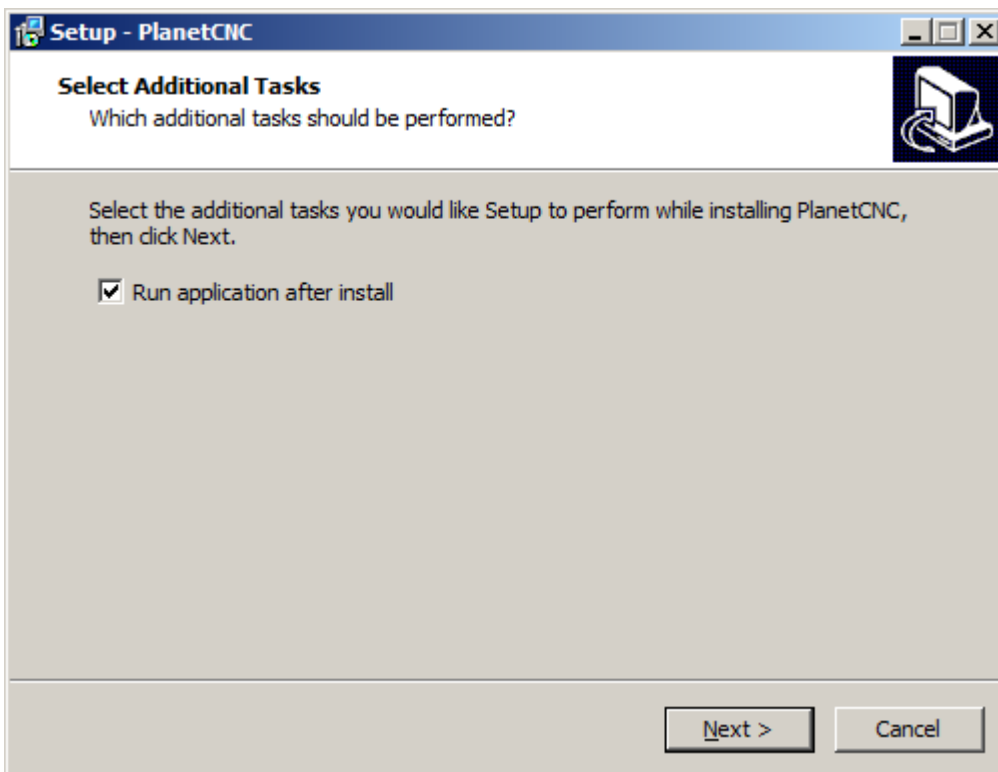

Setup-PlanetCNC dialogue will ask if you are ready to install, click *Install*:

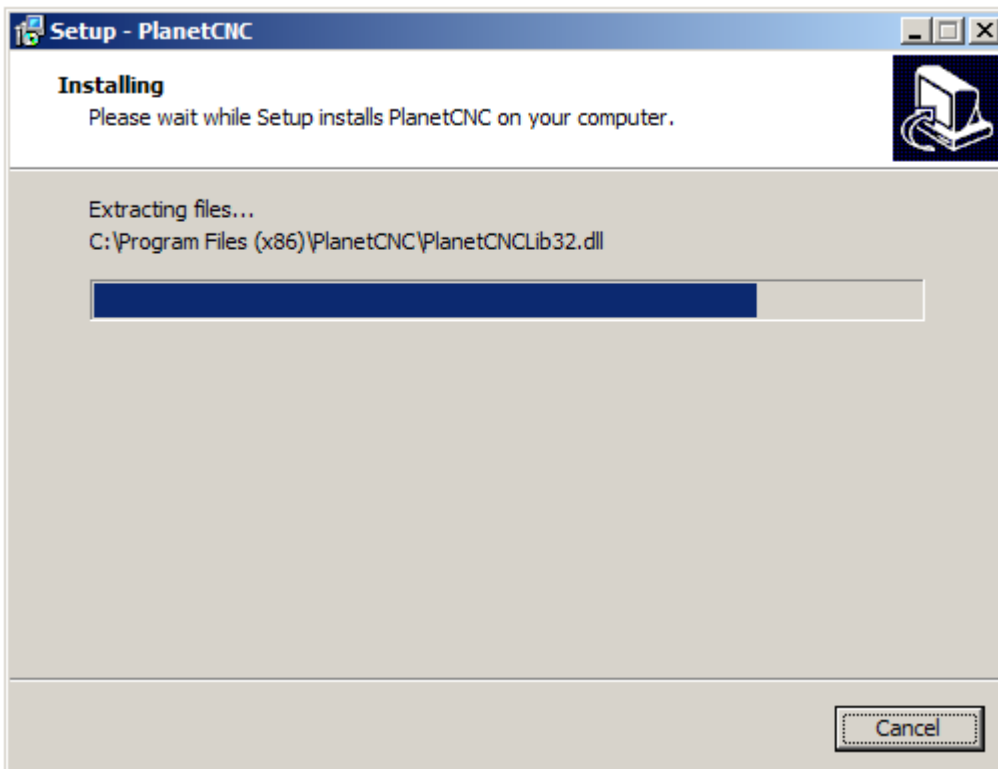
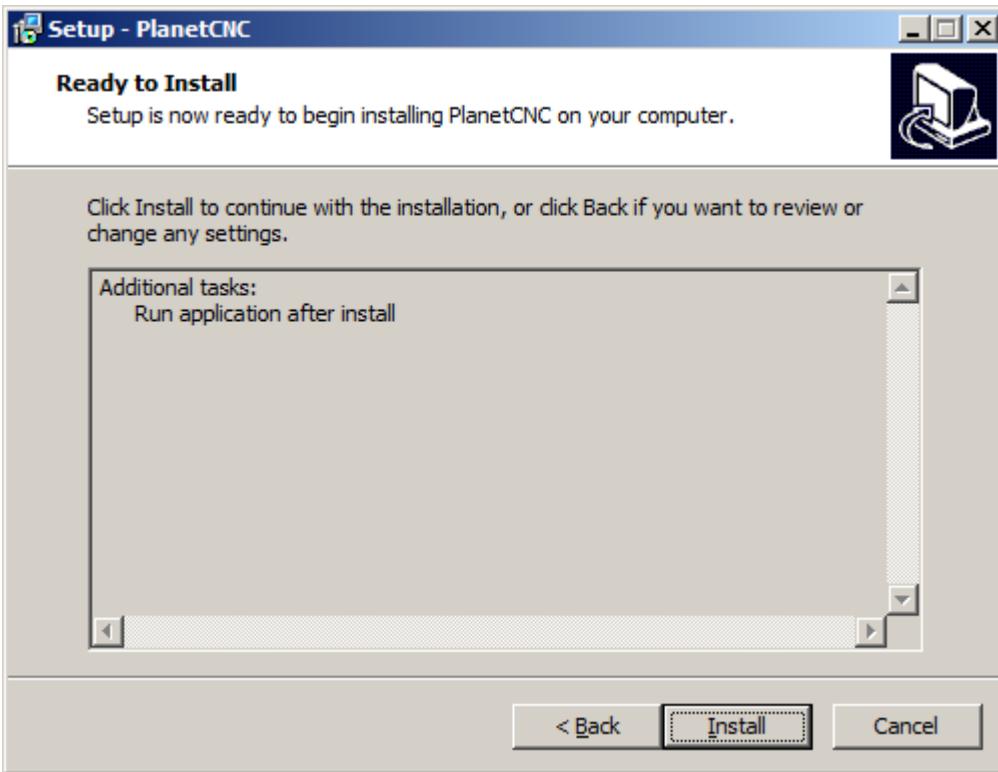

Complete PlanetCNC Setup wizard by clicking *Finish*:

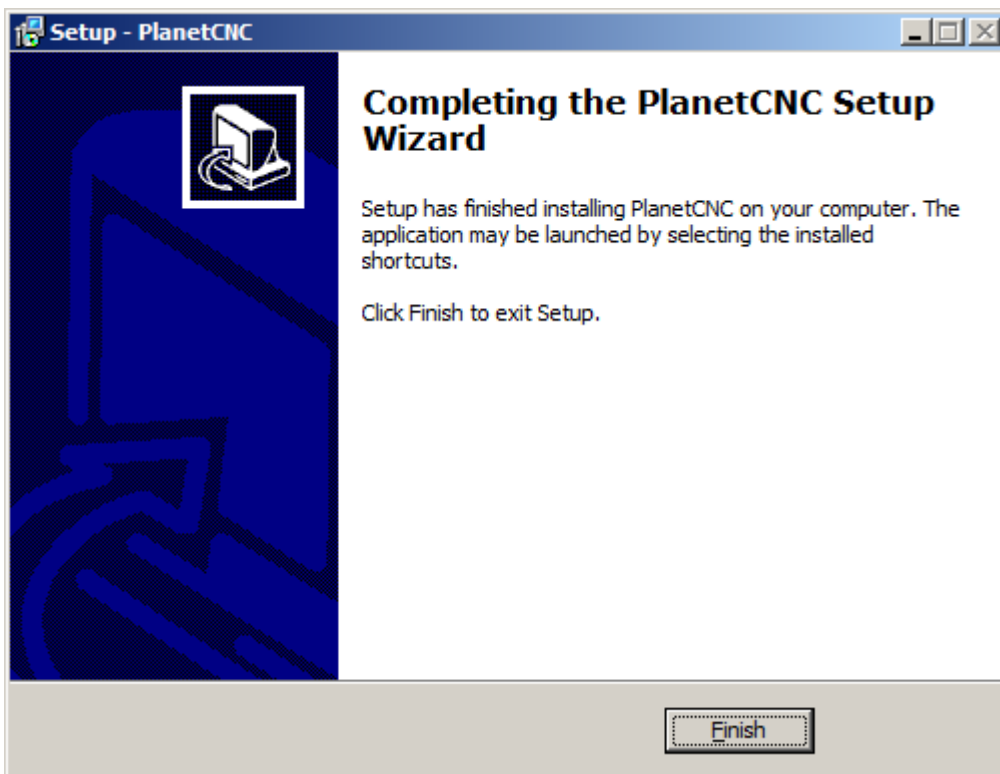

2.2.2

2.2.3 Software installation on Linux

We used freshly installed Linux – Ubuntu MATE distribution for this guide. Please note that distributions differ one from another so these steps may not be suitable for all distributions and installation methods may vary.

Start your Ubuntu MATE system:

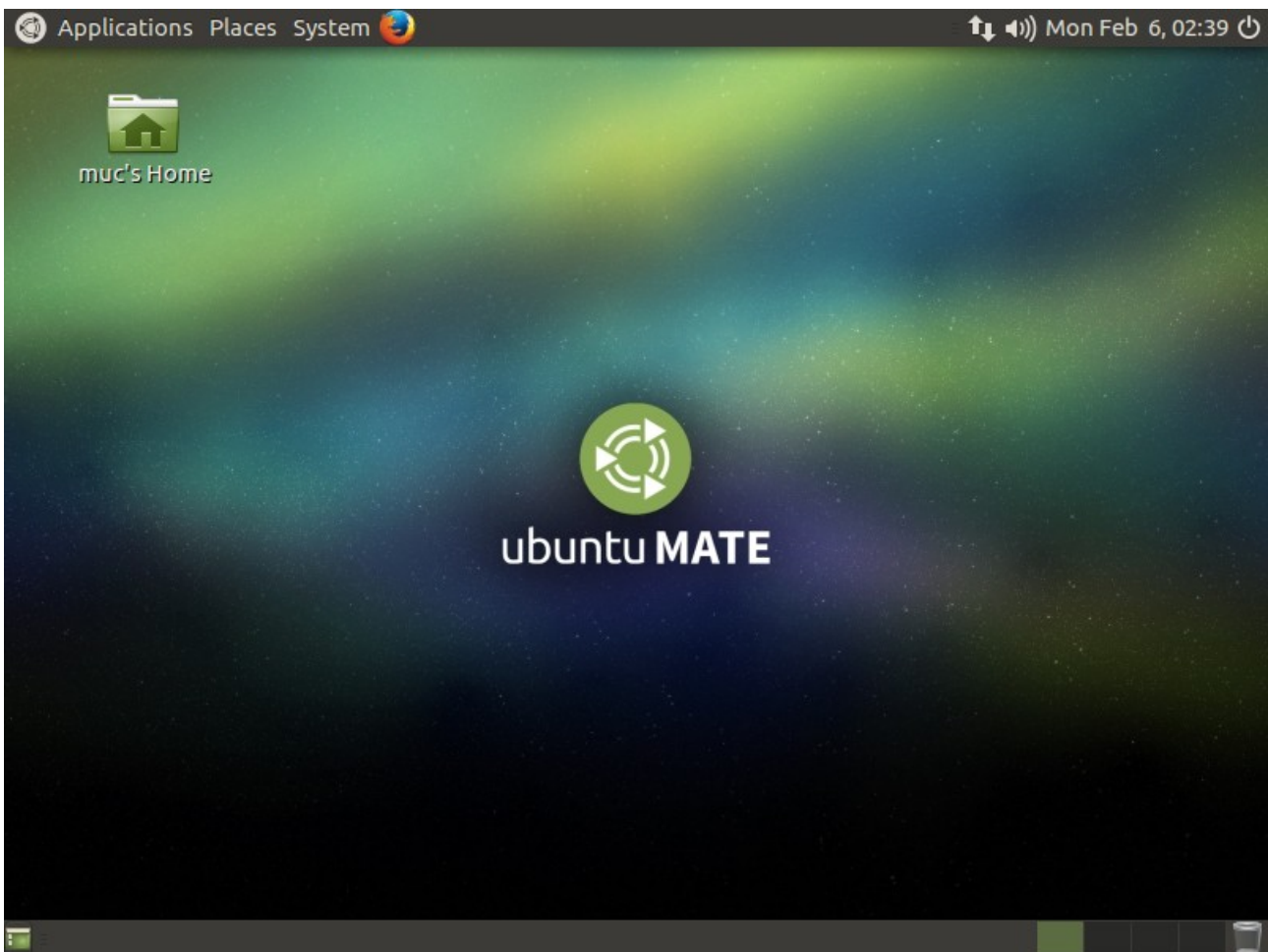

Using your web browser, download PlanetCNC TNG version from PlanetCNC download page:
<https://planet-cnc.com/software/>

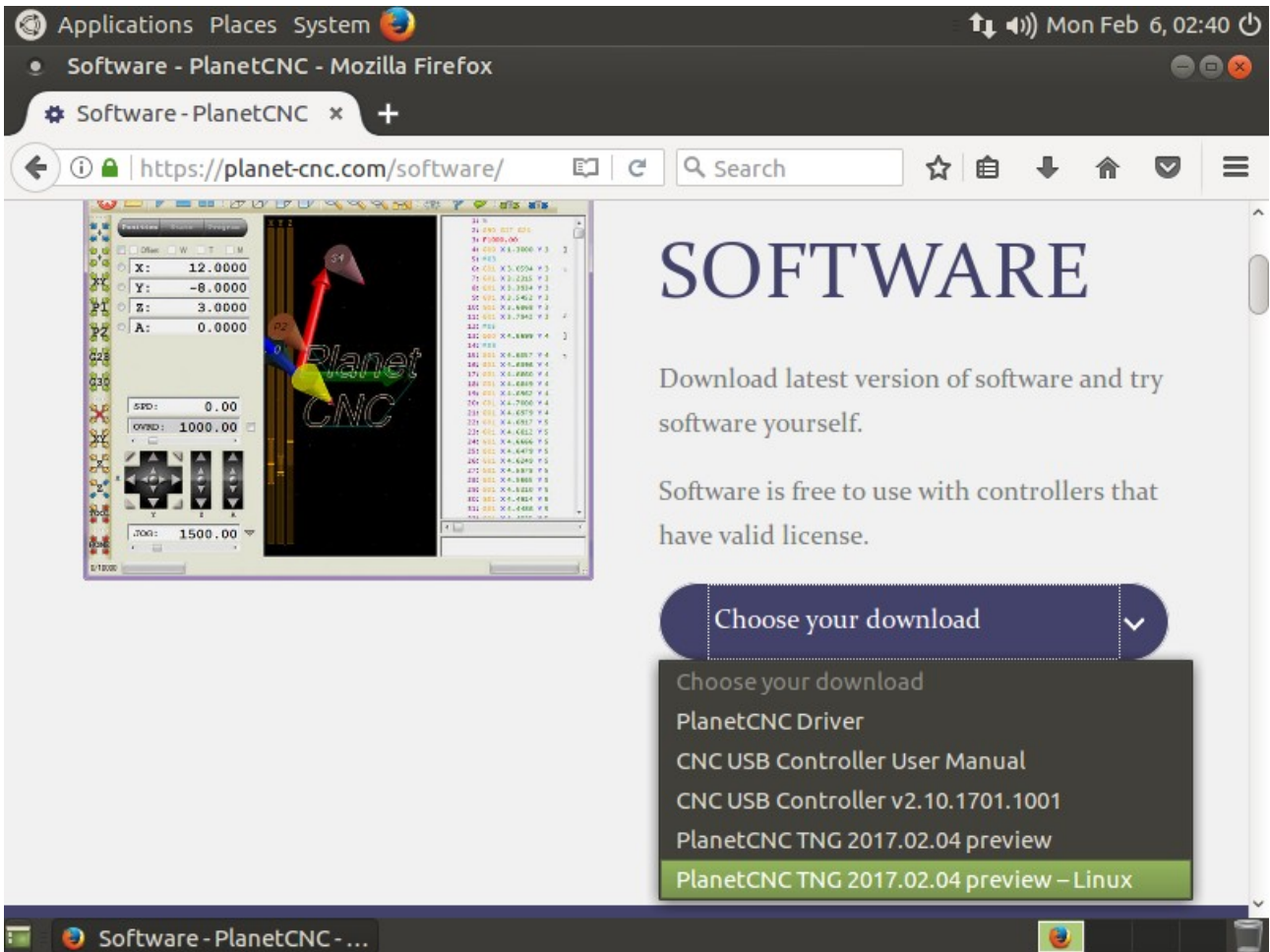

Under download options choose *PlanetCNC TNG preview-Linux* and click *Download* button:

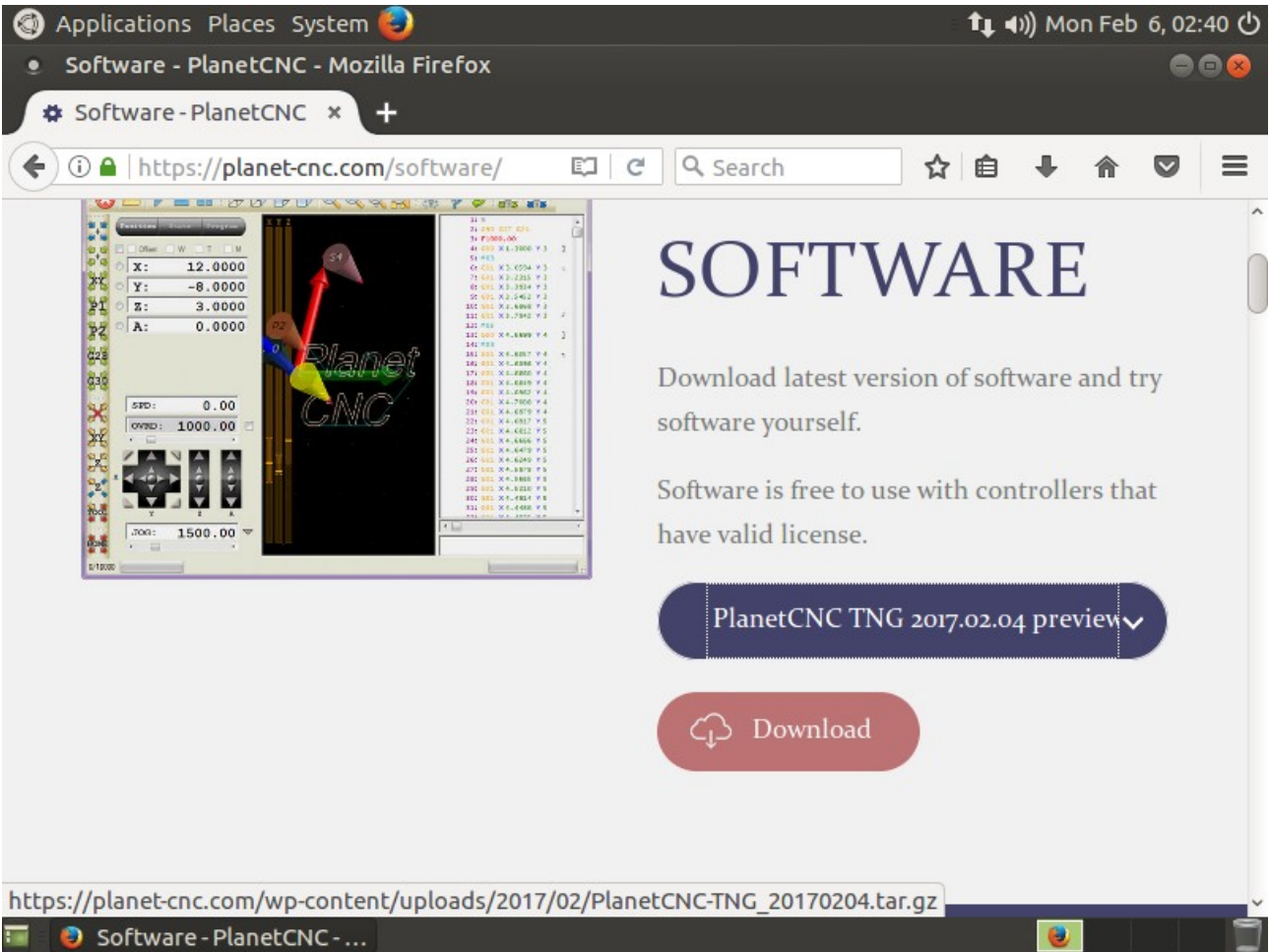

When download dialogue appears, select *Save File* and hit *OK* button:

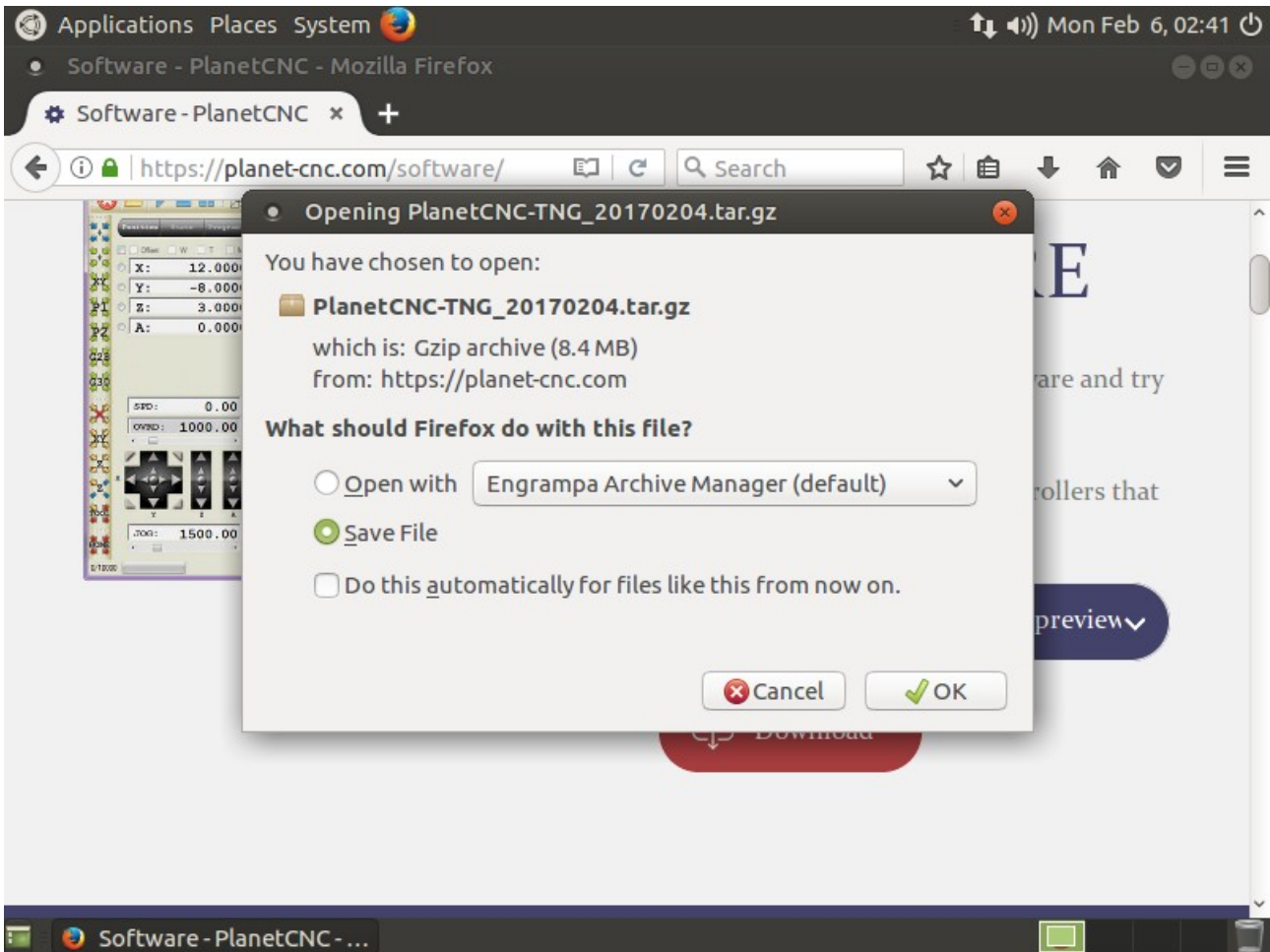

When download is complete, click *Open folder* button:

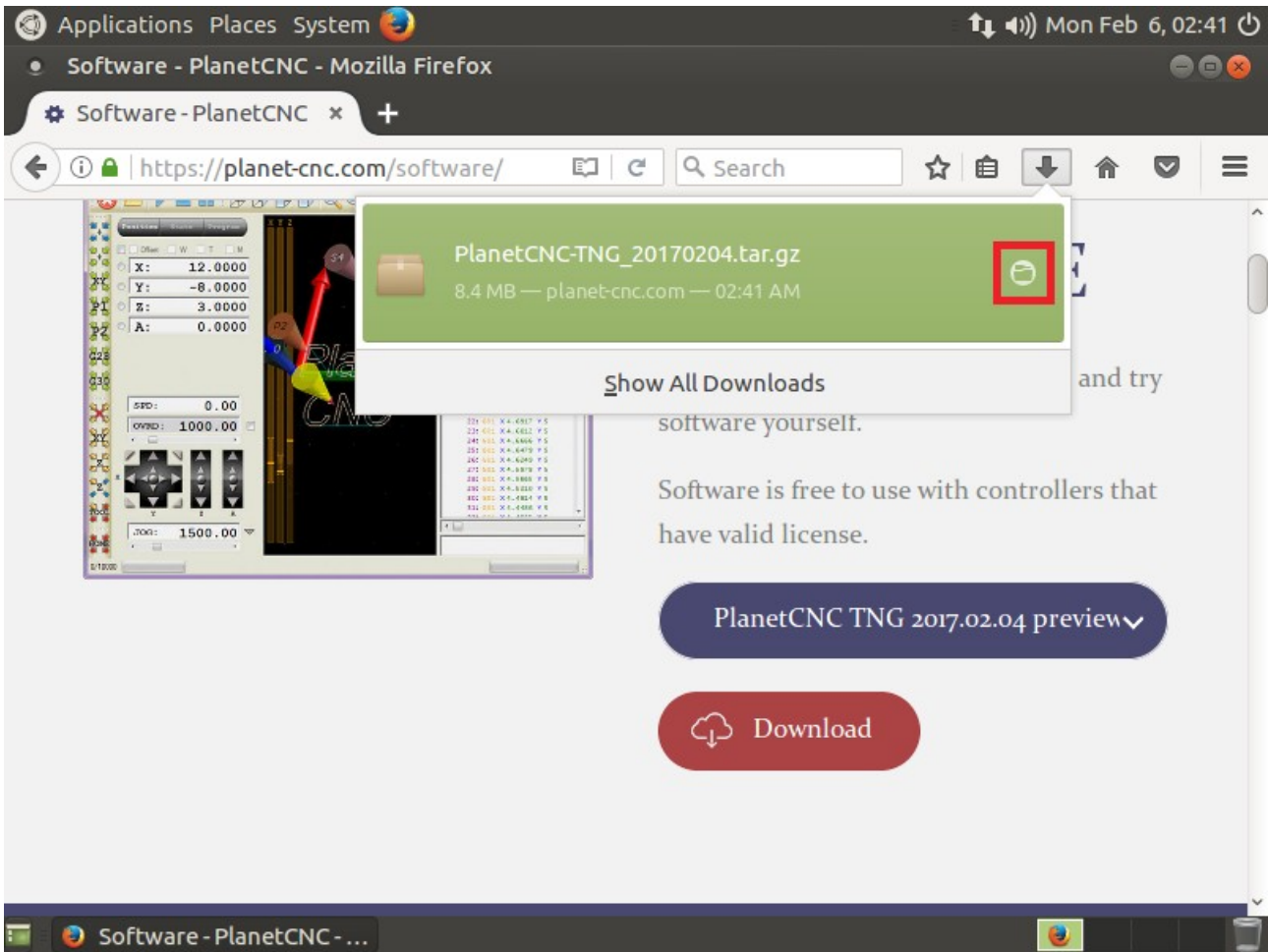

In *Downloads* folder, right click on downloaded file and click: *Extract To...*:

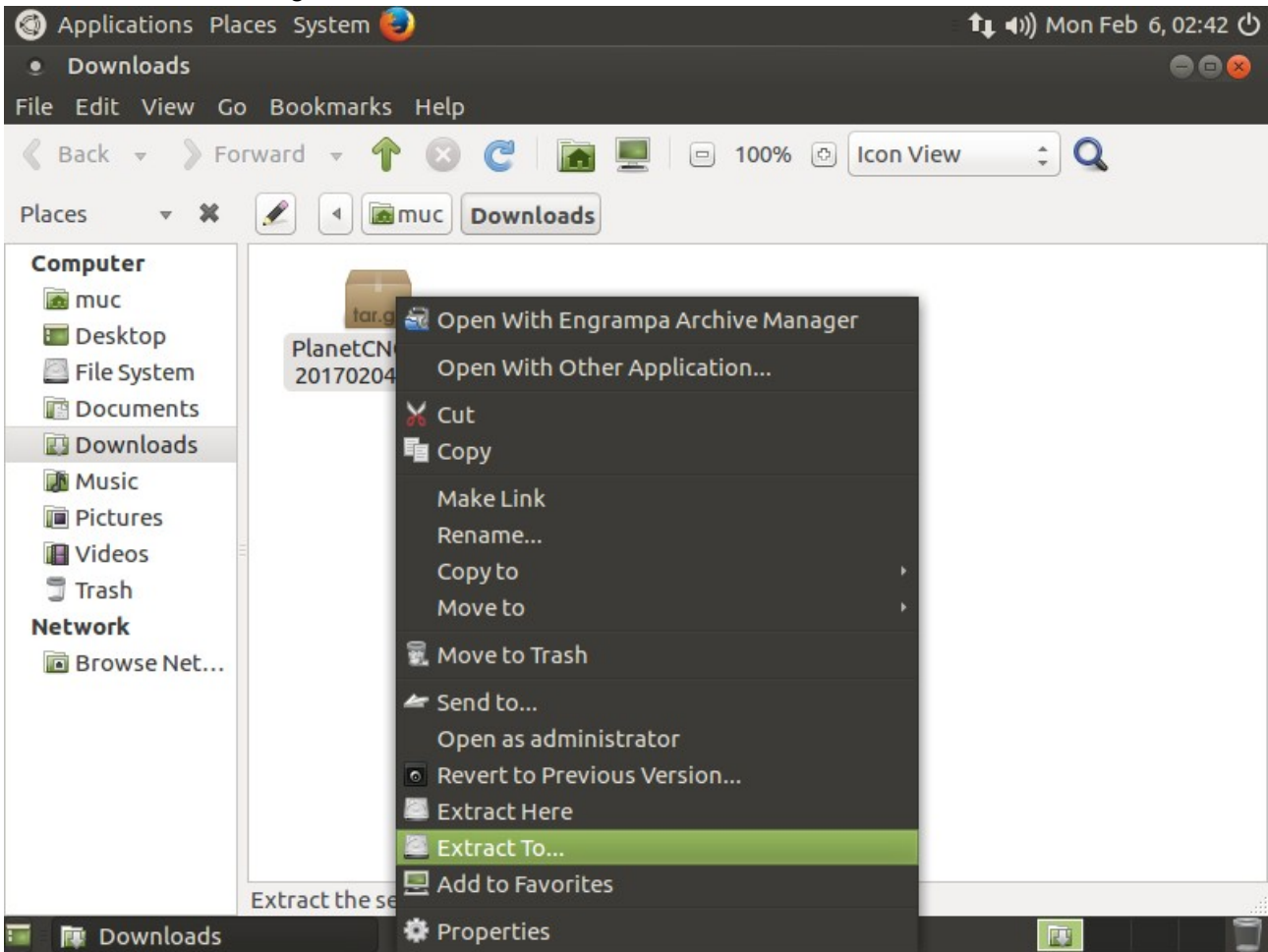

Extract dialogue will appear, click: *Create Folder* button:

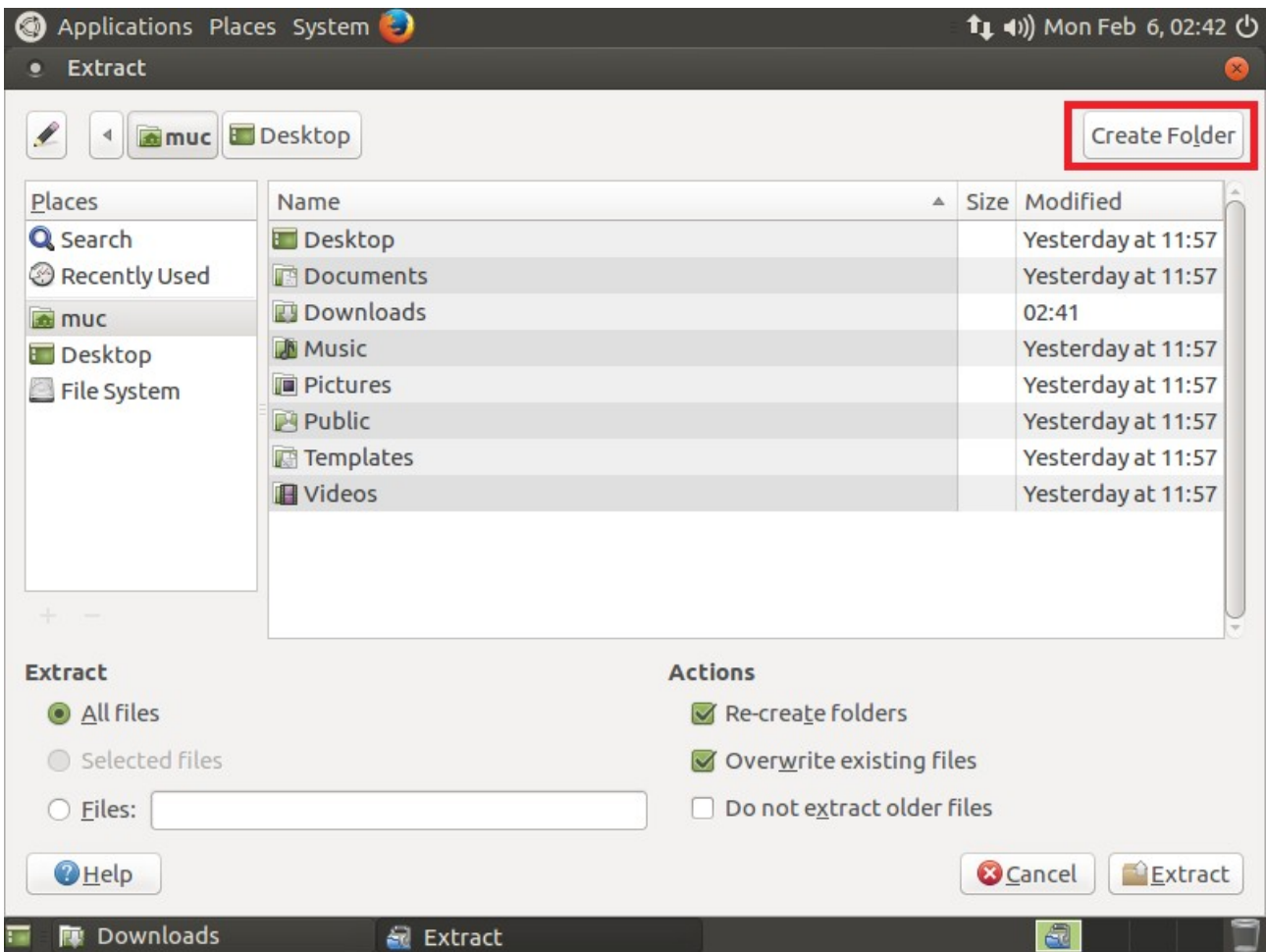

Type in the name of new folder: PlanetCNC

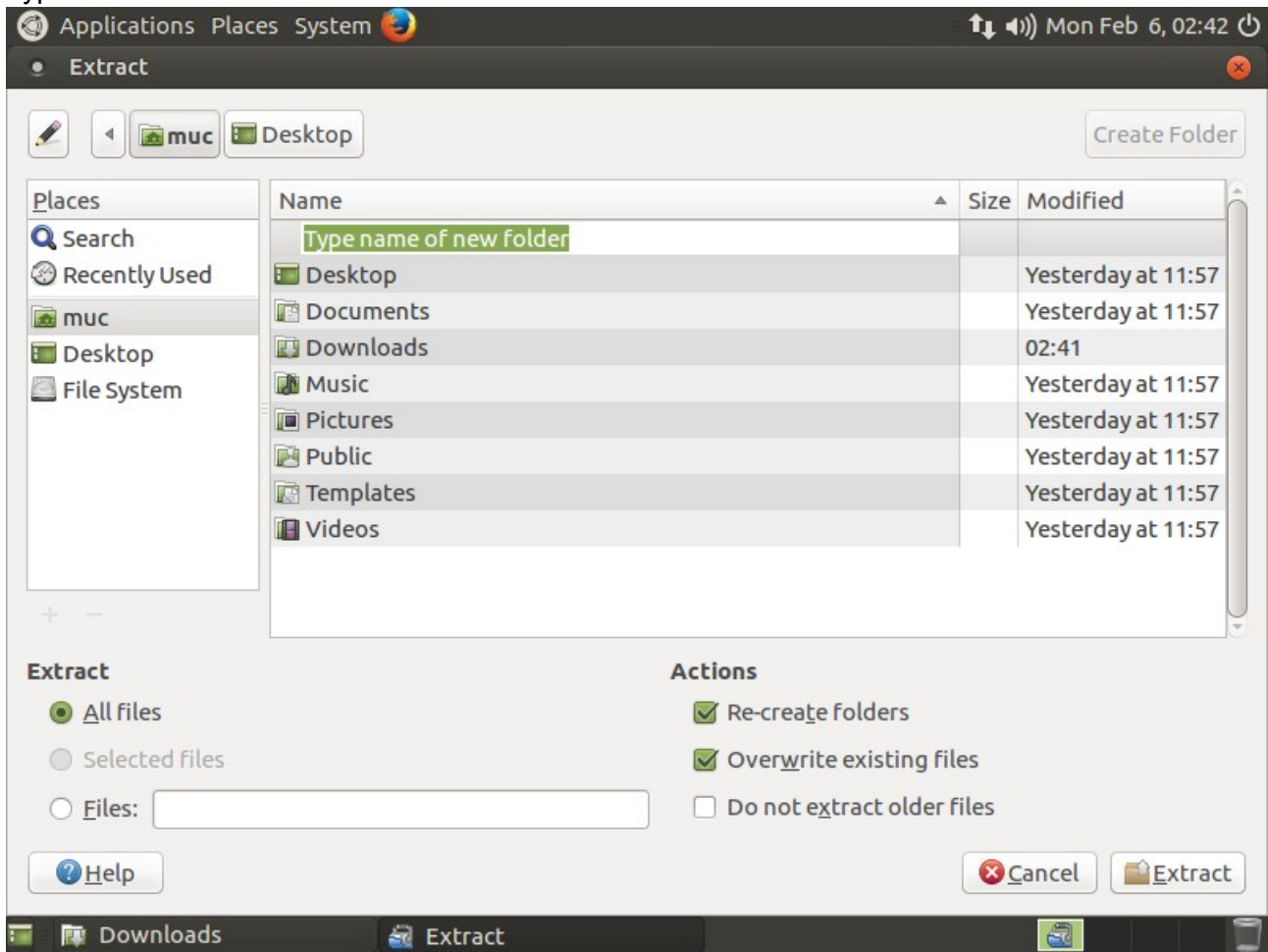

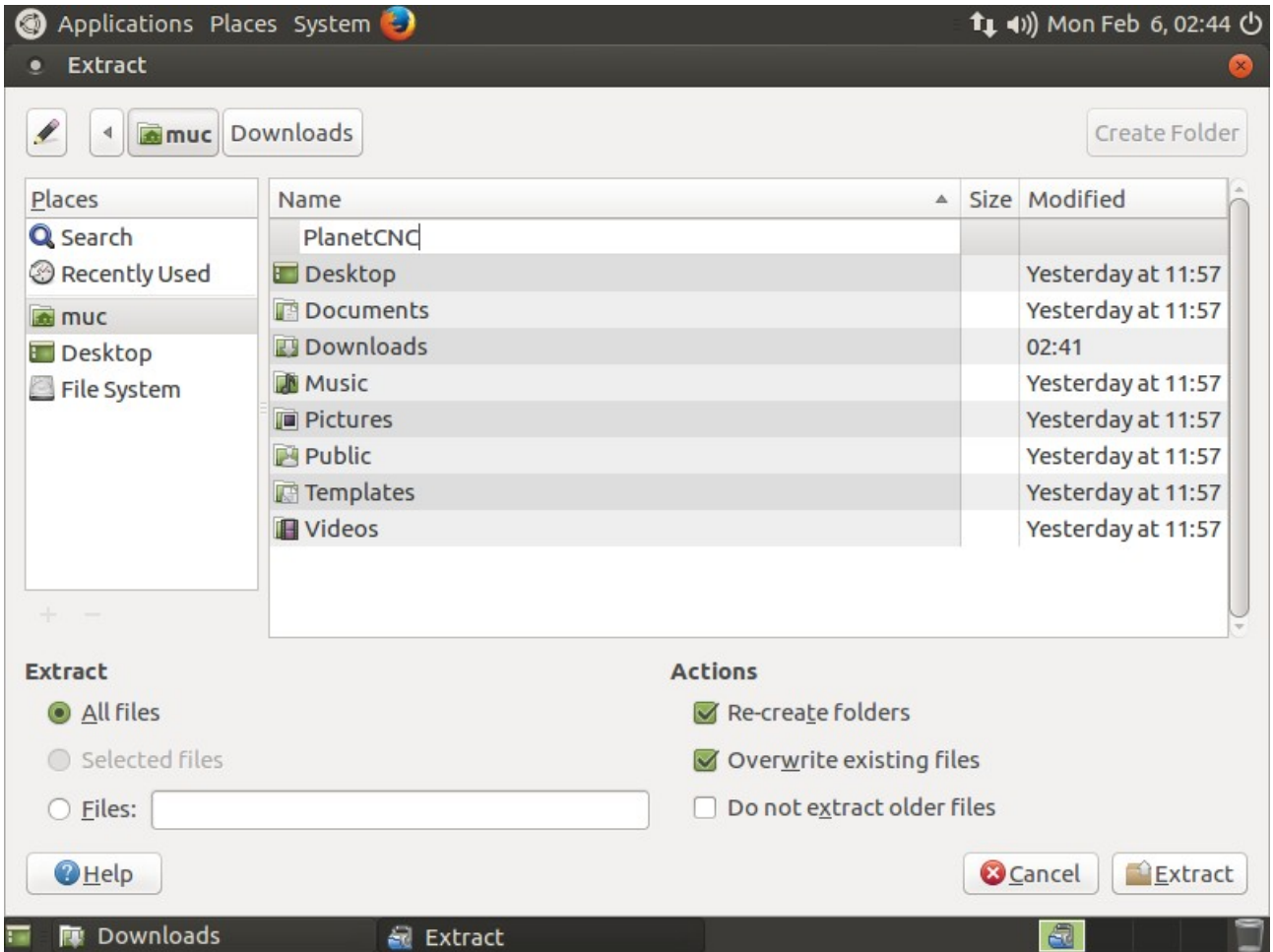

Open PlanetCNC folder and click *Extract* button:

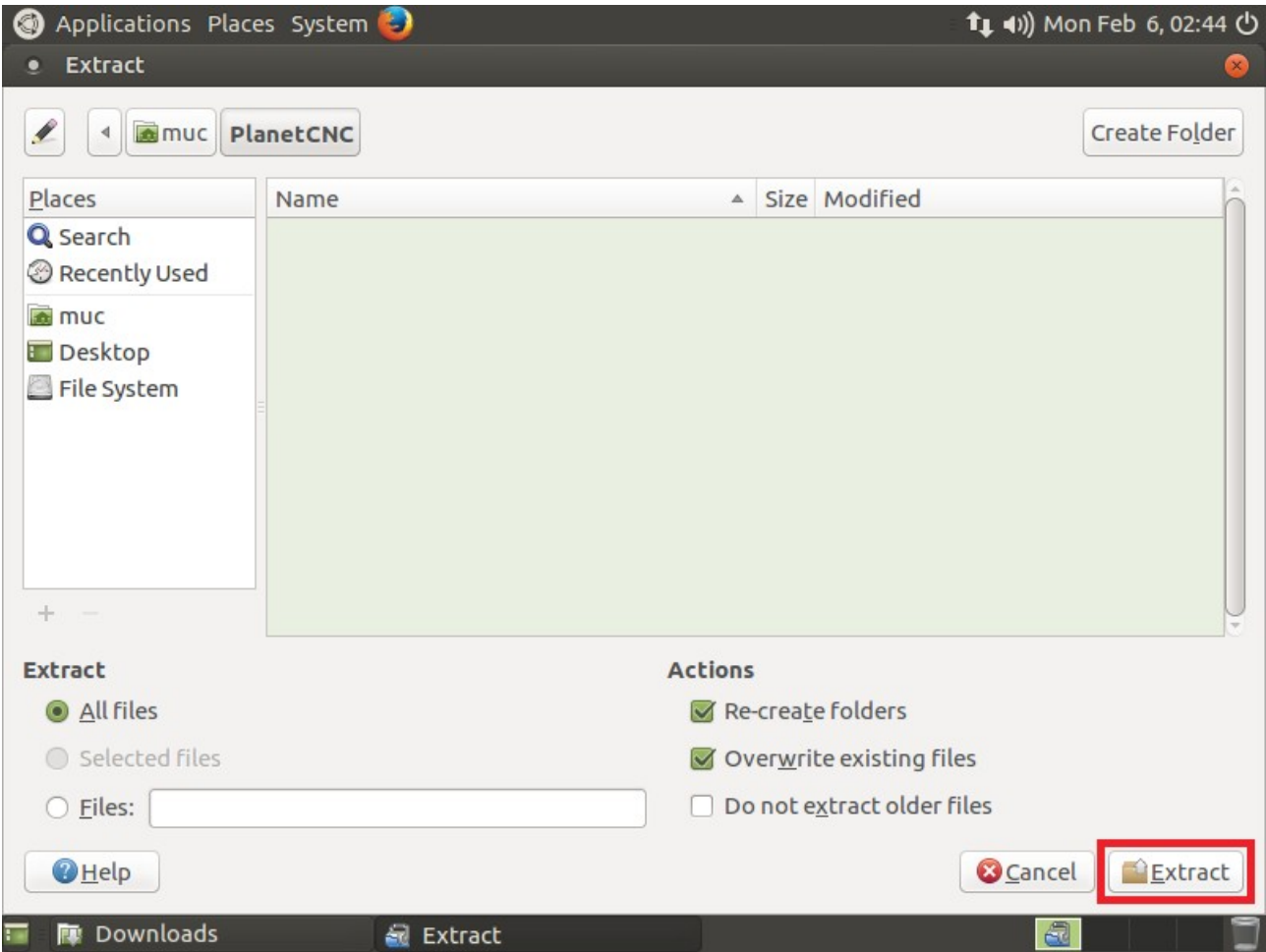

Extracted files will now populate PlanetCNC folder:

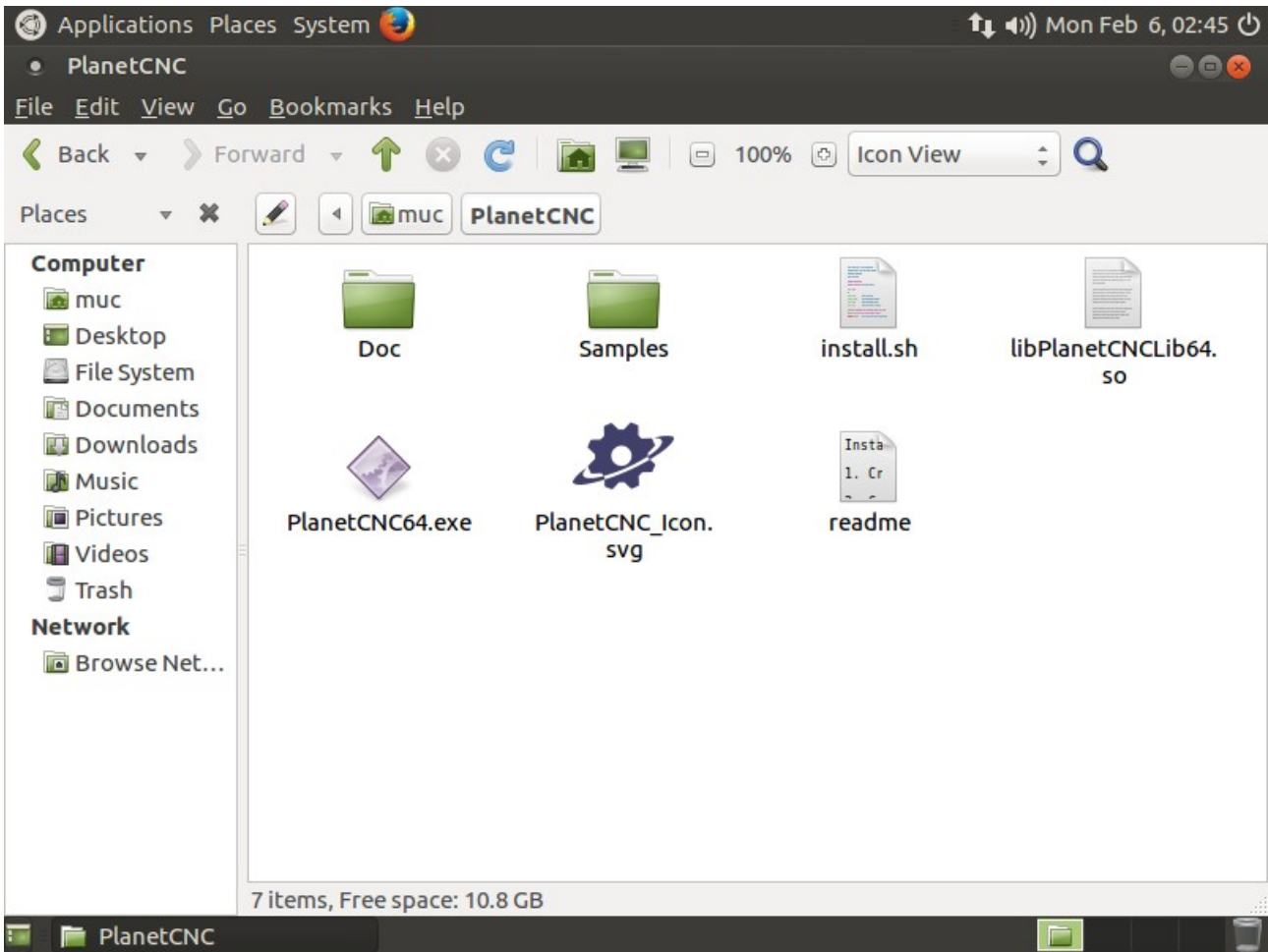

Right mouse click on blank space and click: *Open in Terminal*

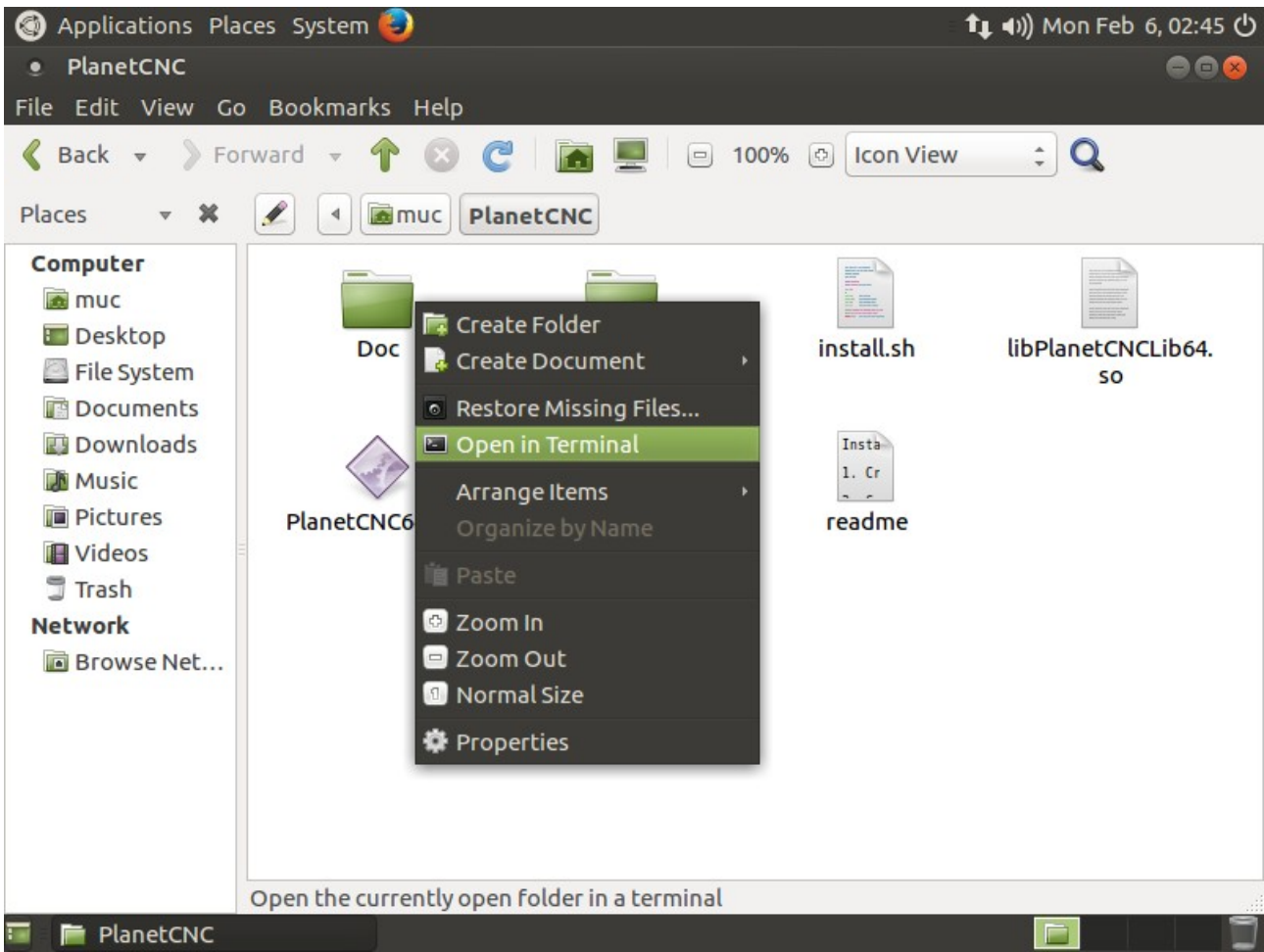

Terminal window will appear:

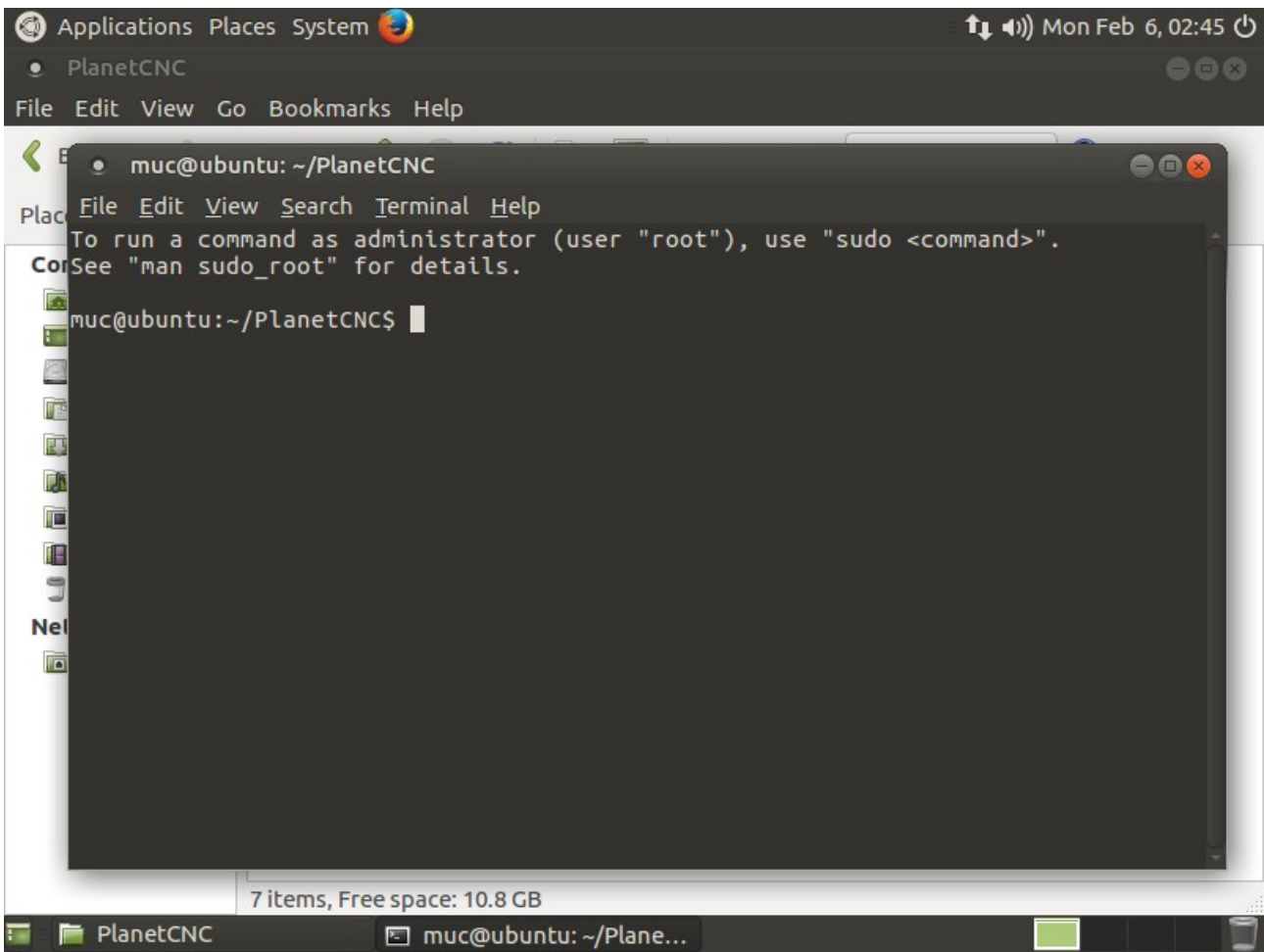

Write: `sh install.sh`

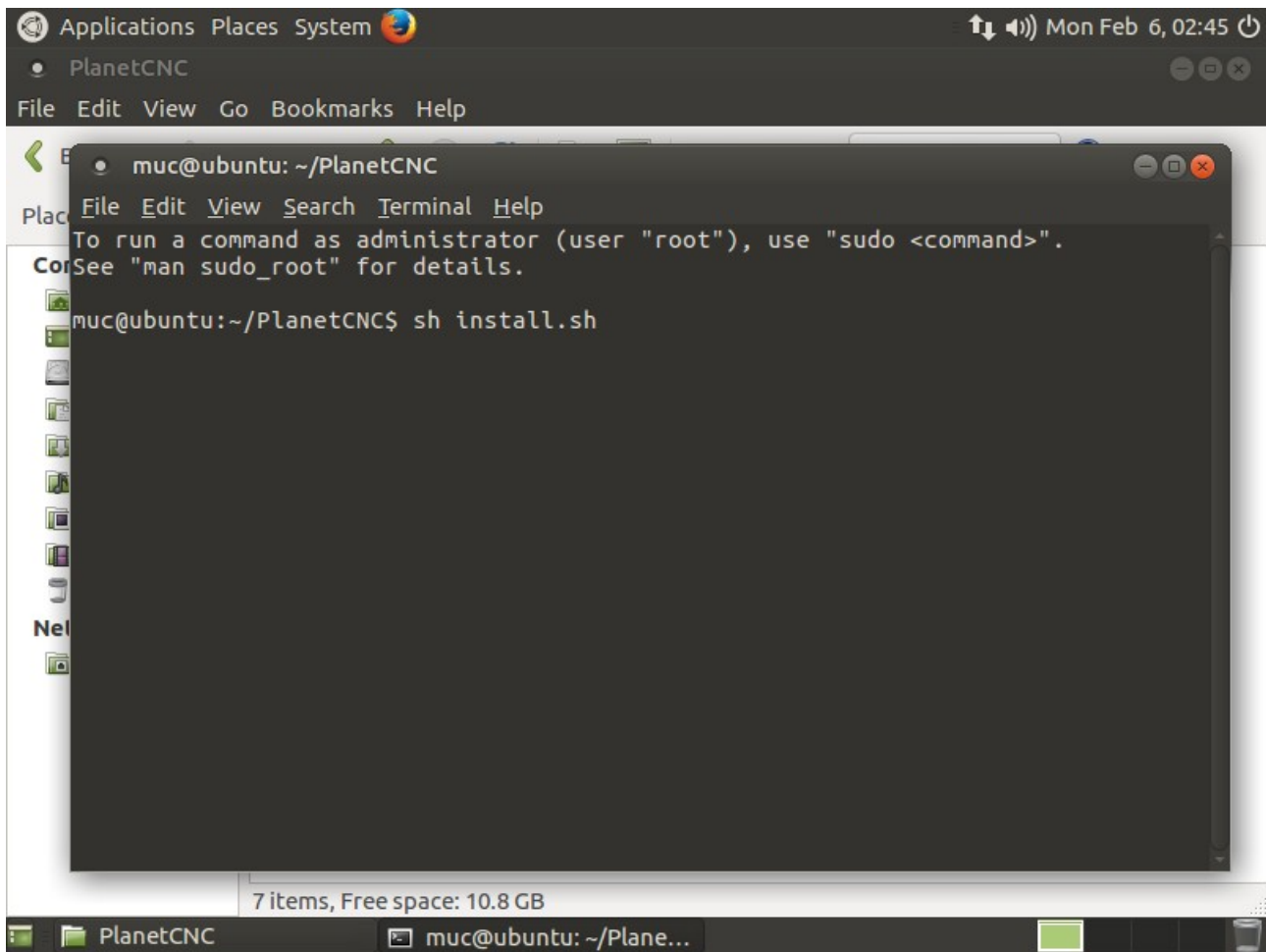

Type in your root password and hit enter.

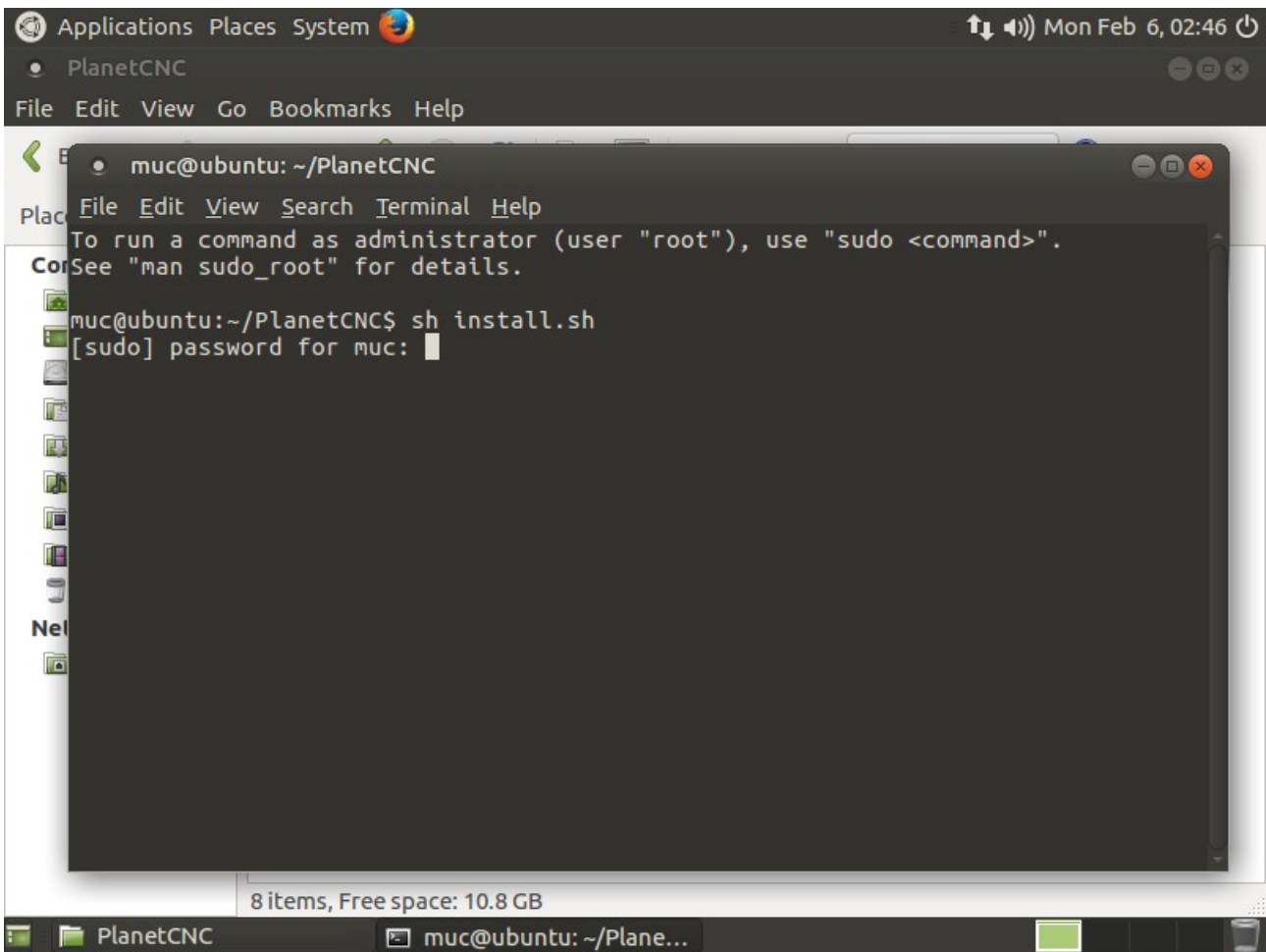

PlanetCNC TNG software will automatically launch:

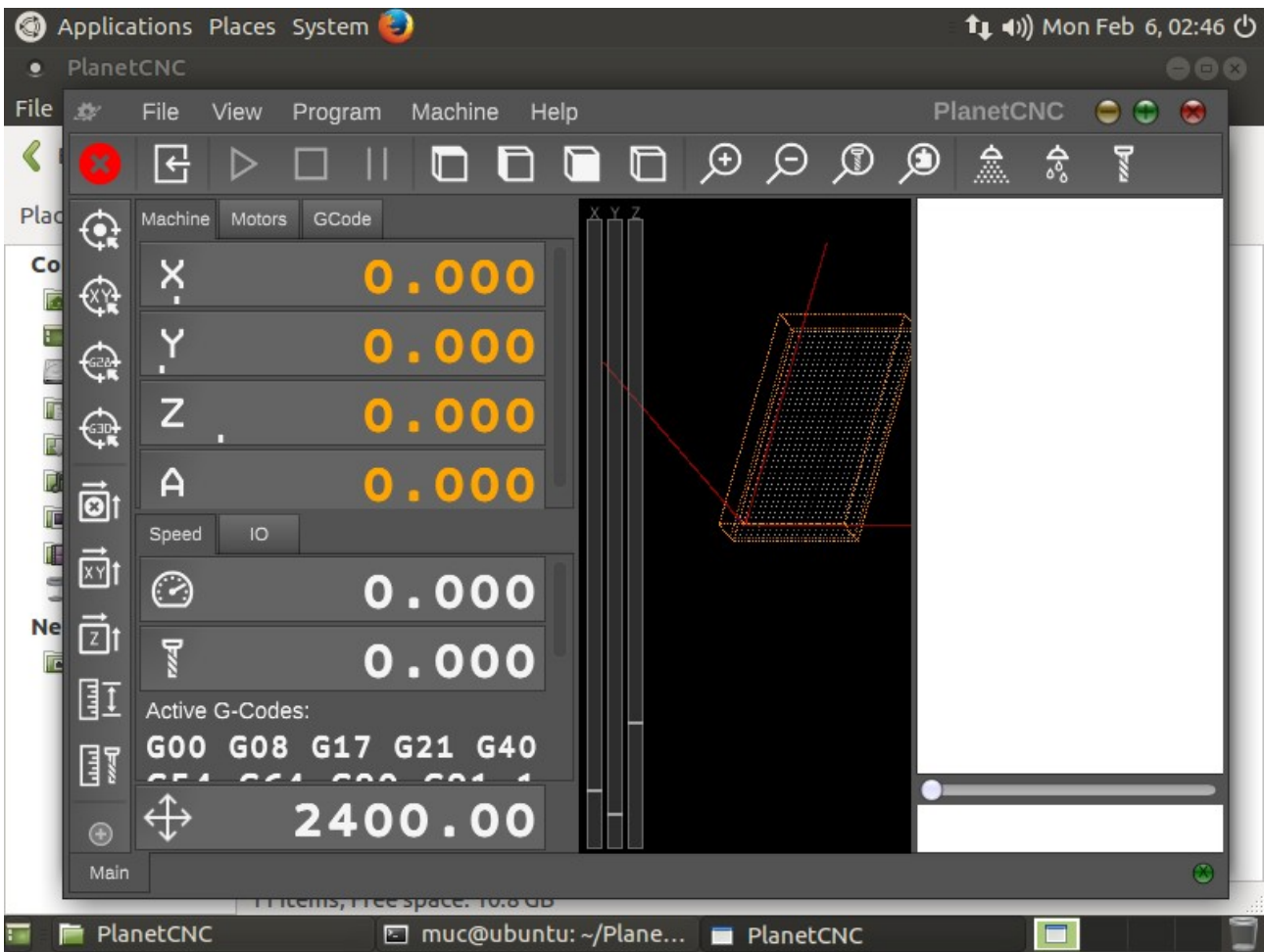

2.3 Main Window

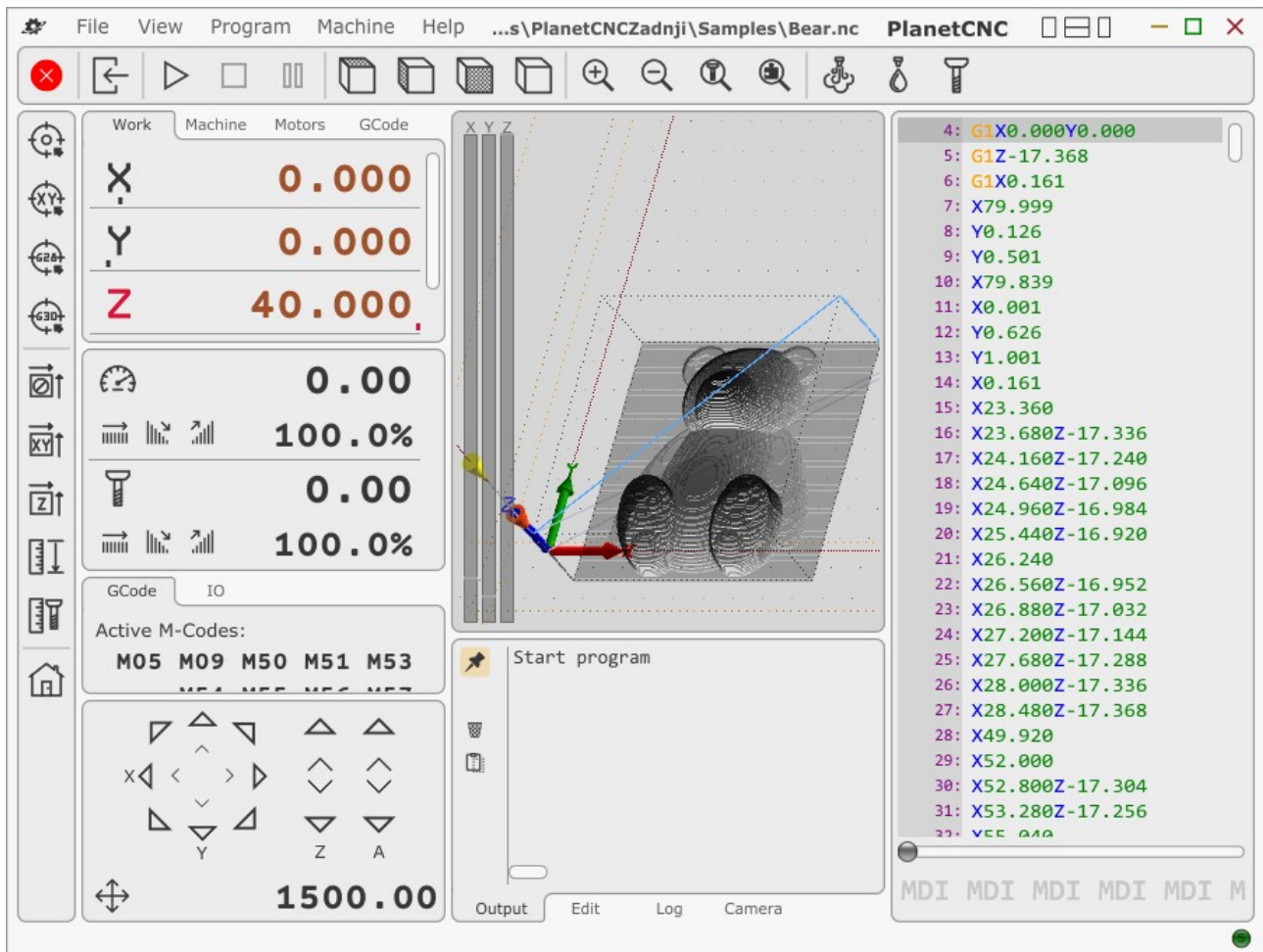

On launch of PlanetCNC TNG software, *Main Window* will display.

Main window consists of nine sections - panels. Each provides information or function concerning machine control, G-Code program execution, displaying machine or controller state, jogging, program editing etc..

- Menu bar
- Toolbars
- Position panel
- Speed panel
- State panel
- Jog panel
- 3D
- Gcode panel
- Utilities panel

2.3.1 Menu bar

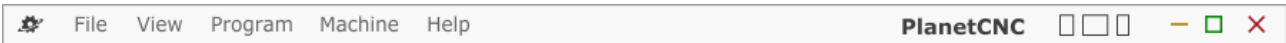

Menu bar is populated by *File*, *View*, *Program*, *Machine* and *Help* menu items as also main window manipulation buttons. If file is imported, file name and file path are displayed:



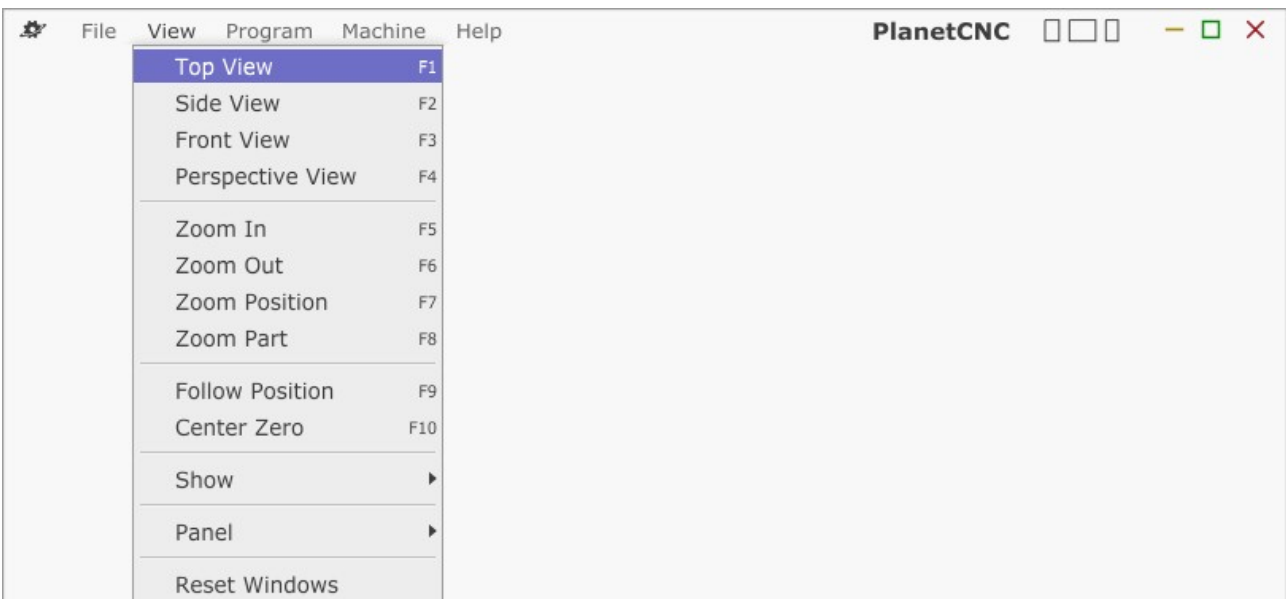

Drop down menu will appear if you click on a dedicated menu item:



2.3.1.1 Buttons for panel display manipulation

On the right side of menu bar are buttons for panel manipulation. Left button is used for show/hide of *Position*, *Speed*, *State* and *Jog* panels, centre button is used for show/hide *Utilities* panel and right button is used for show/hide of the *G-code* panel. When button is enabled its shape will change.

All three buttons disabled: 

All three buttons enabled: 

Also buttons for minimize, resize and close PlanetCNC TNG main window: 

You can hide/show Position, Speed, State and Jog panel with left button:

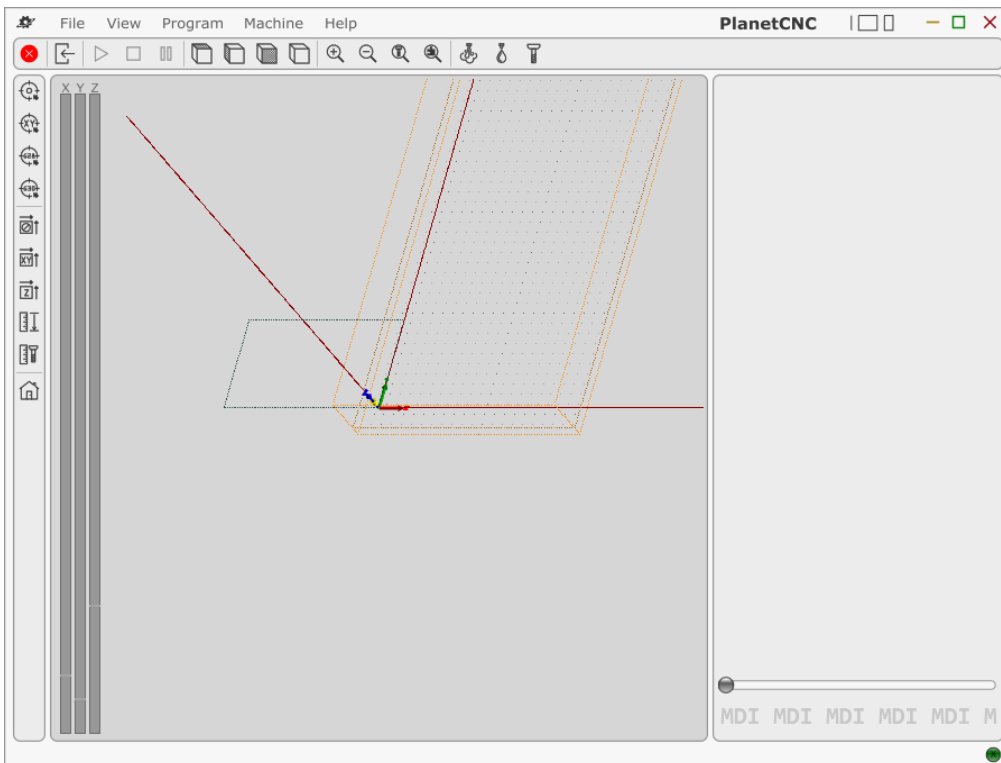
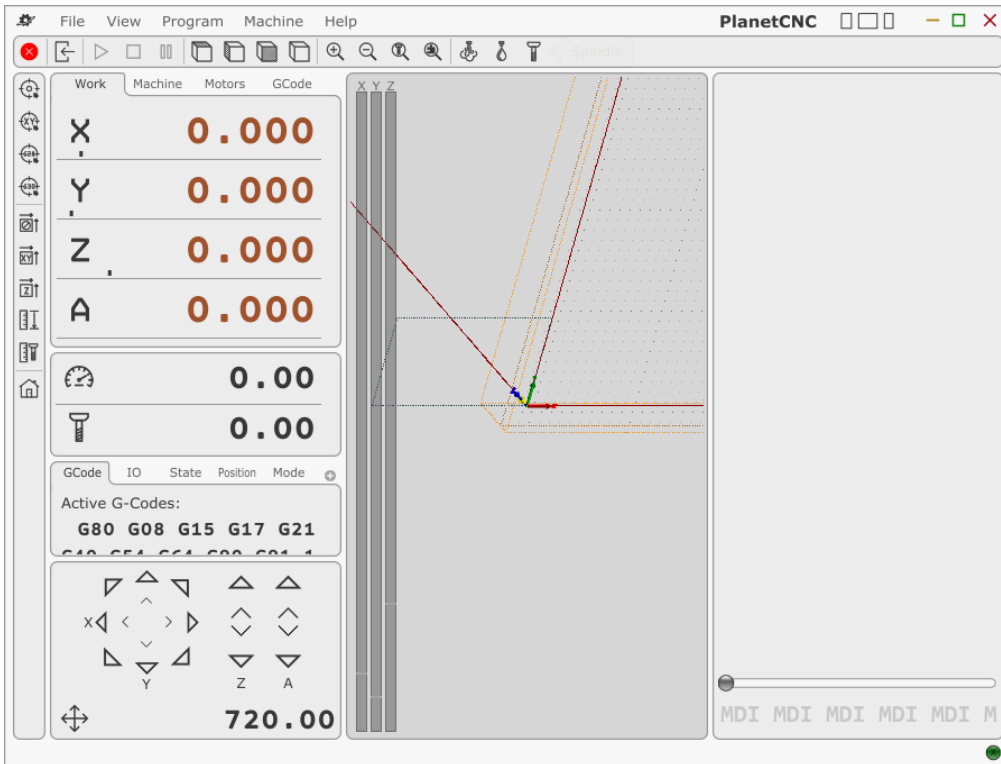

You can hide/show G-code panel with right button:

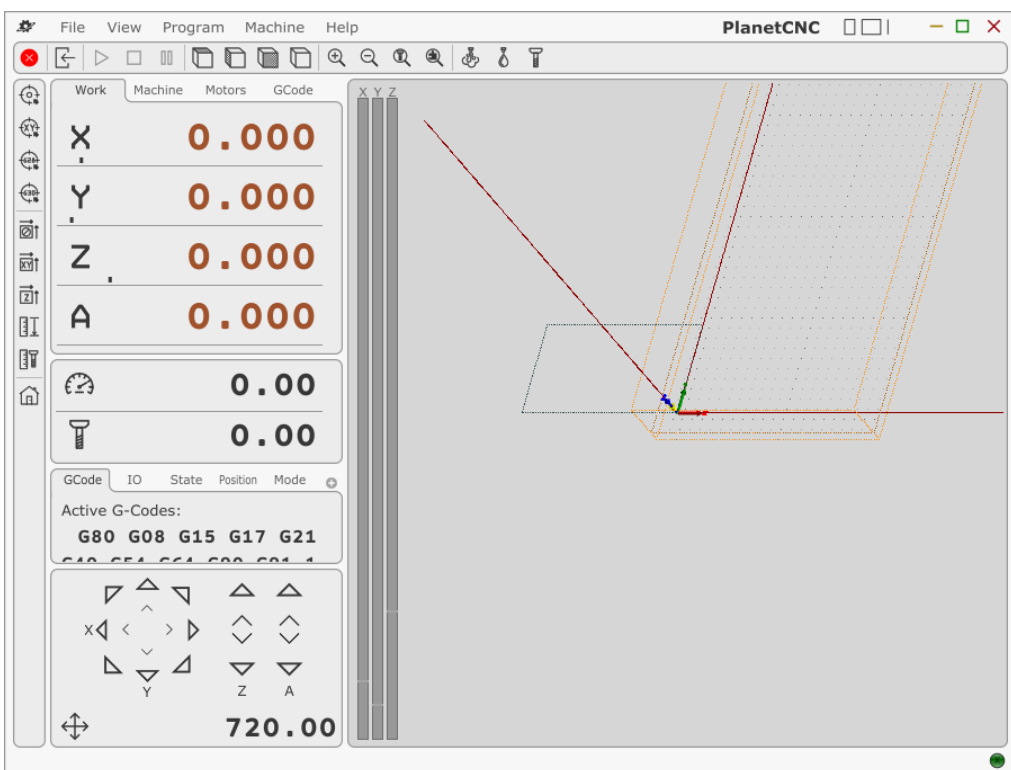
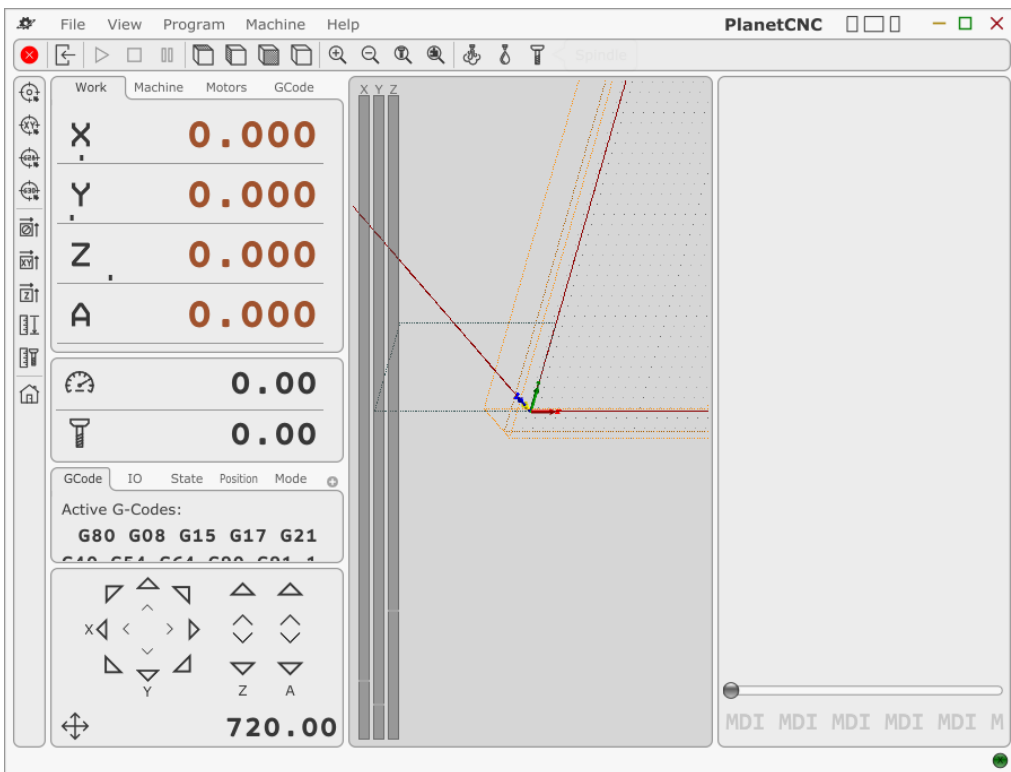

You can hide/show utilities panel with centre button:

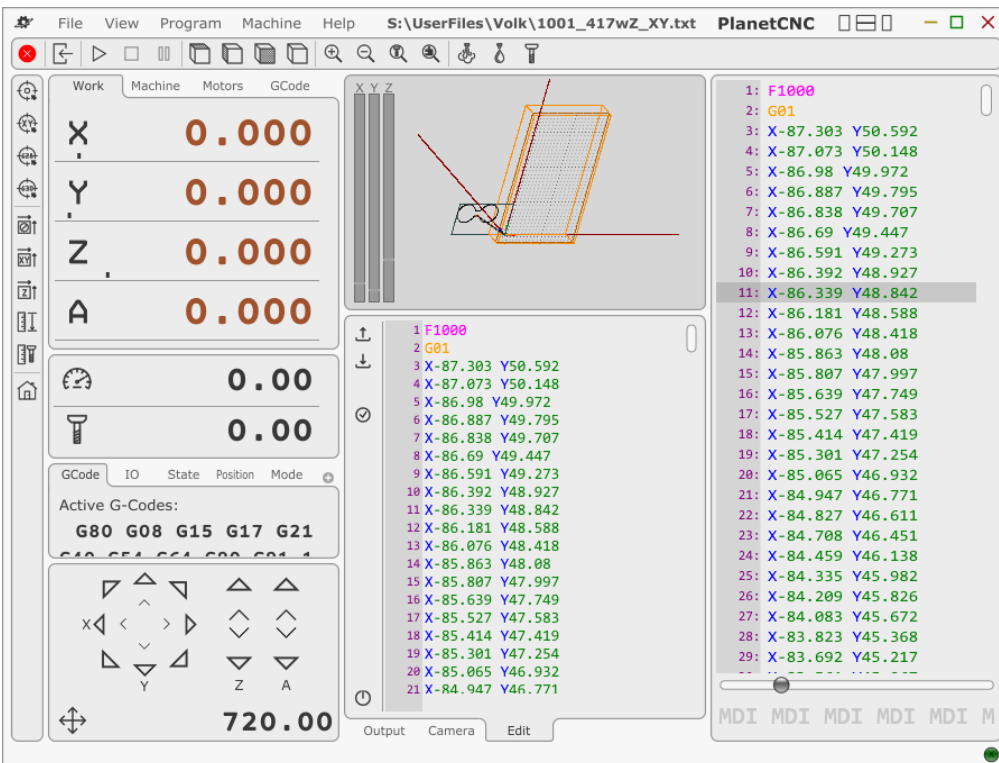
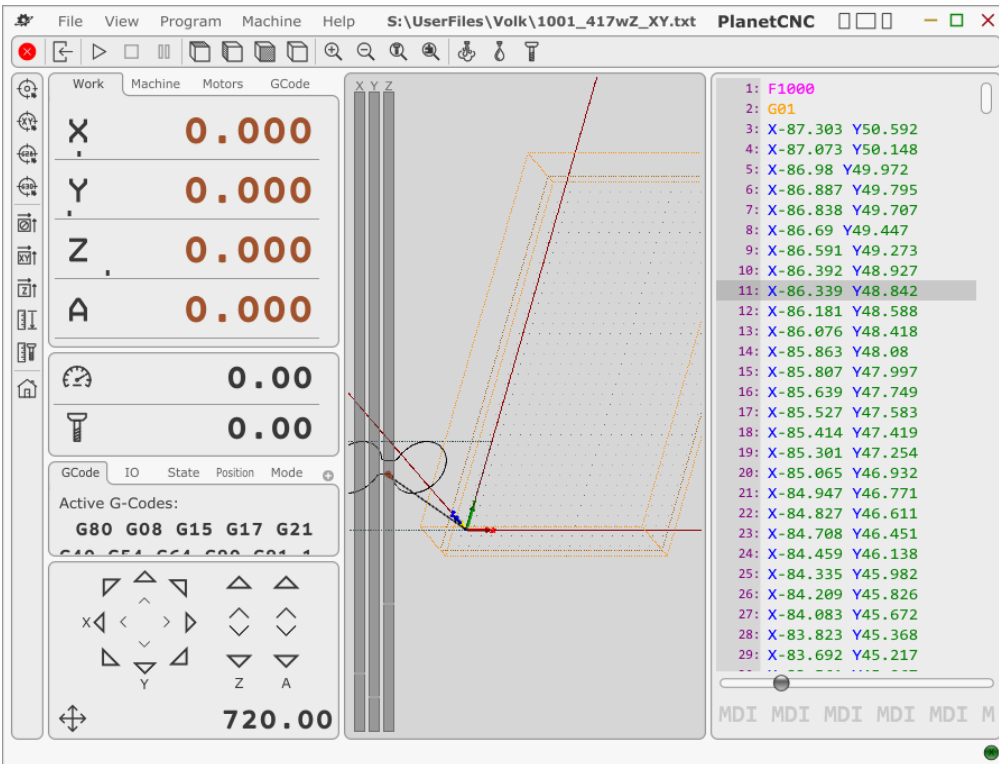

2.3.2 Toolbars

2.3.2.1 Top toolbar:



Emergency stop:	Executes immediate Emergency Stop (E-Stop)
Open program:	Loads a G-Code program
Start execution:	Start program execution
Stop execution:	Stop program execution
Pause execution:	Pause program execution
Top View:	Display G-Code program view from the top
Side View:	Display G-Code program view from the side
Front View:	Display G-Code program view from the front
Perspective View:	Display G-Code program using 'Perspective' view
Zoom In:	Zoom display in to view details
Zoom Out:	Zoom display out to view a larger area
Zoom Tool:	Zoom display to the current tool position
Zoom Extents:	Zoom display to the G-Code program extents
Mist:	Activate / Deactivate Coolant Mist
Flood:	Activate / Deactivate Coolant Flood
Spindle:	Activate / Deactivate Spindle

2.3.2.2 Left toolbar:

Move/To Zero:

Moves the machine XY and Z axes to zero position.

Move/Axis To Zero/XY:

Moves the machine X and Y axes to zero position.

Move/To G28:

Moves machine to the absolute G28 position as set with Machine/Absolute Position/As G30.

Move/ To G30:

Moves machine to the absolute G30 position as set with Machine/Absolute Position/As G30.

Work Offset/To Zero:

Sets working offset to zero.

Work Position/Axis To Zero/XY:

Sets the current XY position of machine as zero XY work position.

Work Position/Axis To Zero/Z:

Sets current Z position as zero Z work position.

Work Position/Measure:

Measures Z working position at current machine position, using movable tool sensor.

Tool Offset/Measure:

Measures tool length using a fixed tool sensor.

Home:

Initiate automatic homing procedure.

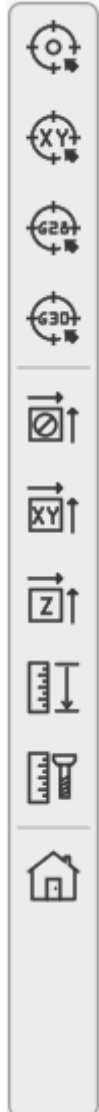

2.3.2.3 *Toolbar additional features*

2.3.2.3.1 **Pop-up clouds**

If you hover a mouse cursor over toolbar button, pop-up cloud with buttons name appears:



2.3.2.3.2 **Spindle and coolant buttons**

If *Mist*, *Flood* and *Spindle* output pins are configured in settings, then when buttons are activated either directly via toolbar or dedicated spindle or flood g-codes *M3*, *M7*, *M8* are active, buttons will change colour.

Spindle and coolant OFF: 

Spindle and coolant ON: 

2.3.2.3.3 **Adding toolbars**

User can add additional toolbars to main window and populate them with user created buttons.

Example below displays additional bottom (horizontal) and right (vertical) toolbars, both populated with user toolbar buttons (User 1, User 2):

2.3.2.3.4 **Adding user toolbar buttons**

Buttons can be created and added to any existing or newly added toolbar. Buttons can be designed to use custom made graphics or images.

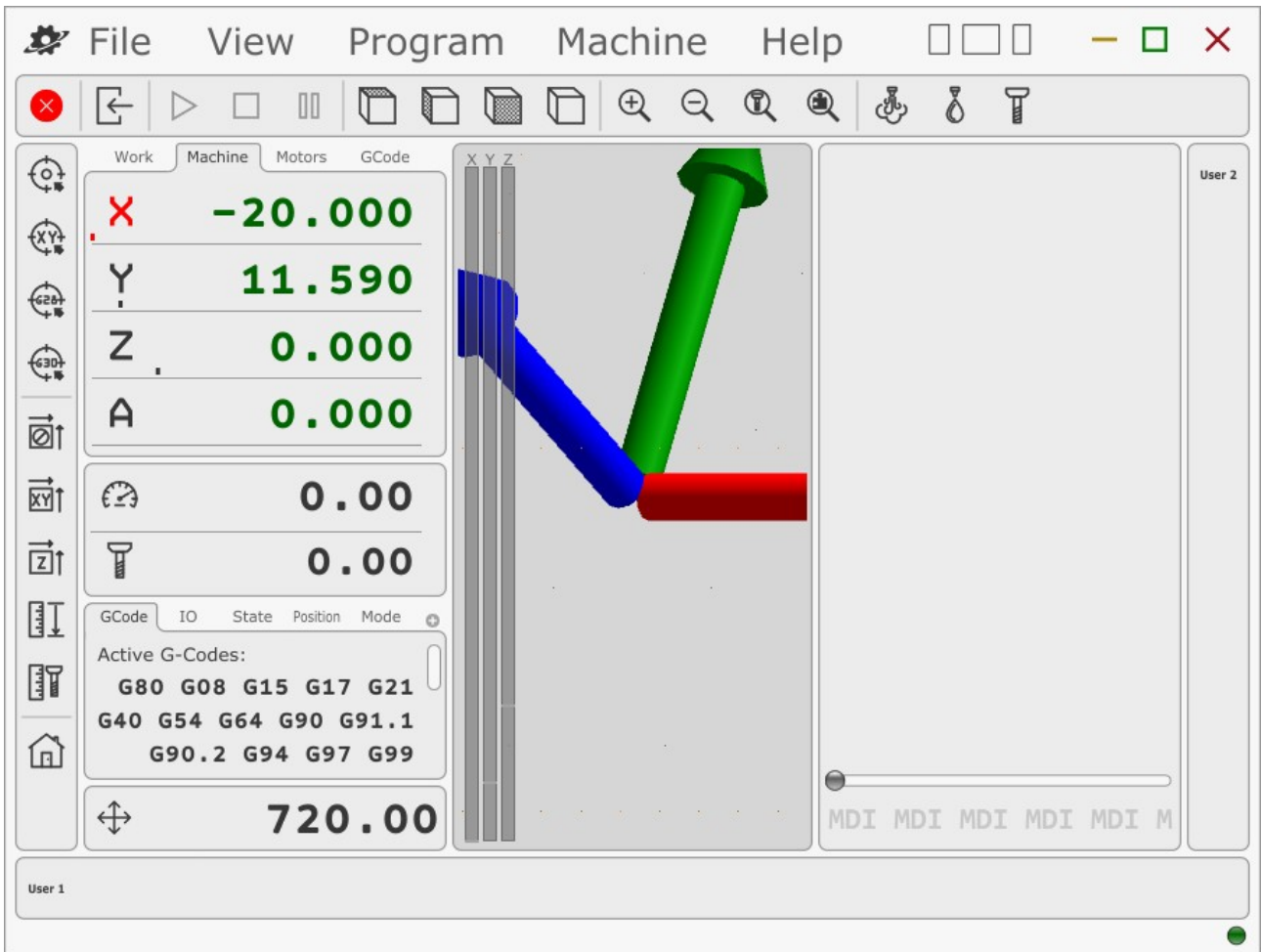

2.3.3 Position panel

Position panel can display four different types of position coordinates.

Each is located under separate position panel tab: *Work*, *Machine*, *Motors*, *GCode*.

2.3.3.1 Work

This tab displays work position coordinates of machine.

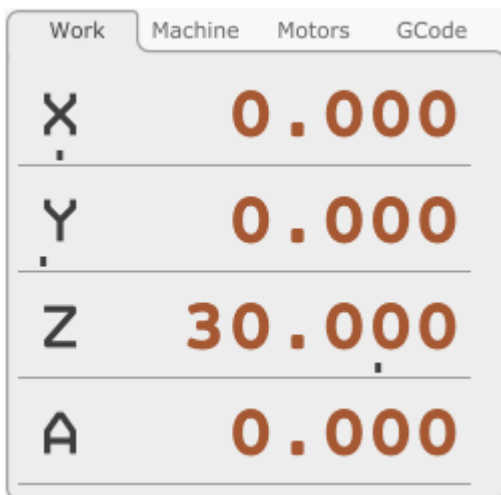

User can set new *Work/Coordinate System* position value by double clicking on the axis position value of *Work* tab. *To Value...* insert field will appear:

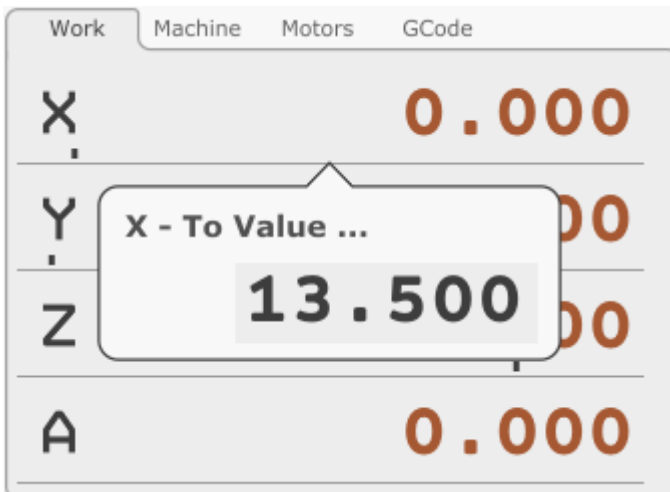

User can set new *Work* zero position value by clicking on the axis zero button:

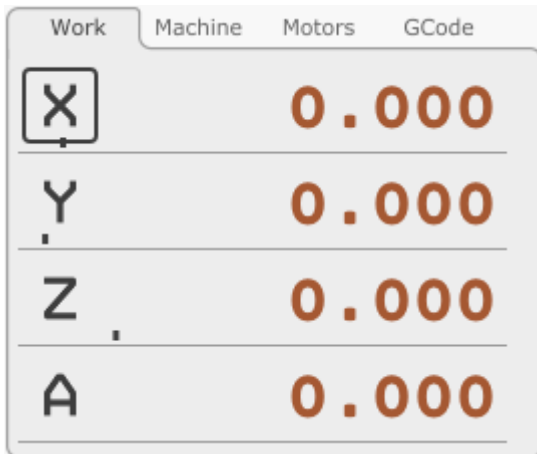

Please note:

As a safety feature, this option needs to be enabled in settings under:

File/Settings/User Interface/Position/Commands

2.3.3.2 Machine

This tab displays machine position coordinates of machine.

Work	Machine	Motors	GCode
X	0.000		
Y	0.000		
Z	30.000		
A	0.000		

User can set new *Machine* position value by double clicking on the axis position value of *Machine* tab. *To Value...* insert field will appear:

Work	Machine	Motors	GCode
X	0.000		
X - To Value ...			
15.000			
A	0.000		

User can set new *Machine* zero position value by clicking on the axis zero button:

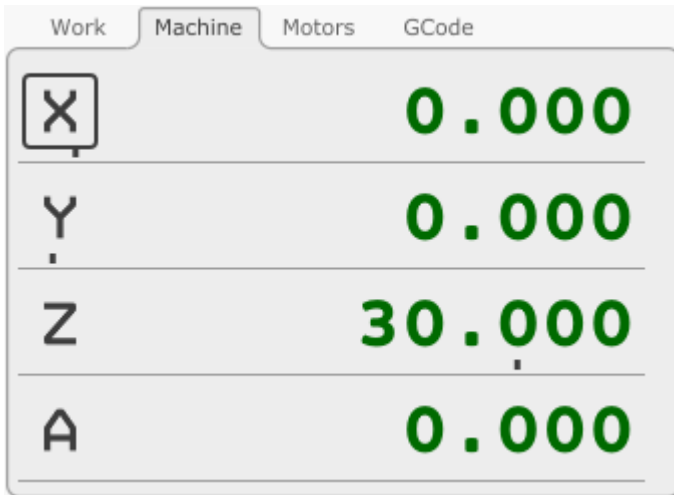

Please note:

As a safety feature, this option needs to be enabled in settings under:

File/Settings/User Interface/Position/Commands

2.3.3.3 Motors

This tab displays motor position coordinates.

Work	Machine	Motors	GCode
X		0.000	
Y		0.000	
Z		30.000	
A		0.000	

2.3.3.4 GCode

This tab displays position coordinates of selected g-code line. These values are relative to machine position.

Work	Machine	Motors	GCode
X		26.880	
Y		1.001	
Z		-17.032	
A		0.000	

2.3.4 Speed Panel

Displays current machine and spindle speed. Additional speed options are available such as feed speed and spindle speed override. Displayed speed can be either speed during jog motion, or feed speed set within the program.





2.3.4.1 Feed speed display:

By clicking speed dial button  additional override feed speed options will appear:



Reset button: Resets any speed override 

Decrease button: Decreases speed override value for 10% 

Increase button: Increases speed override value for 10% 

Mouse cursor can be used to grab and drag the feed override value bar.

Any feed override value other than 100% (100% means no feed override set) will as a result have a coloured speed dial button. This way user can quickly see if feed override is being used.

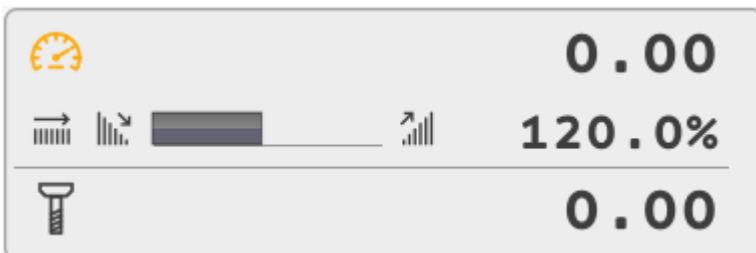

In settings, user can also enable traverse speed override options. Set of buttons for traverse speed override uses symbol of a rabbit:

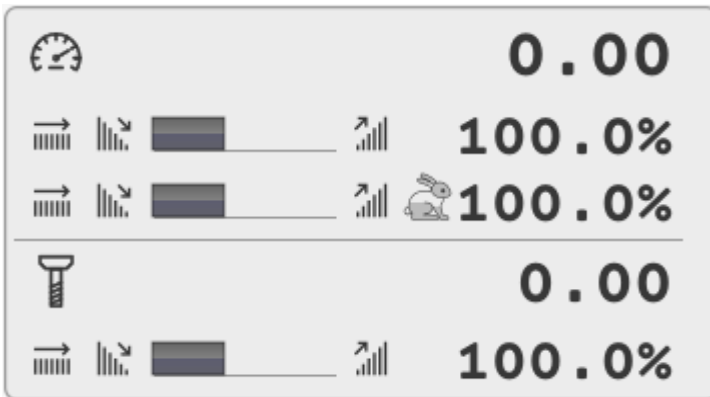

2.3.4.2 Spindle speed display:

By clicking spindle button additional override spindle speed options will appear:

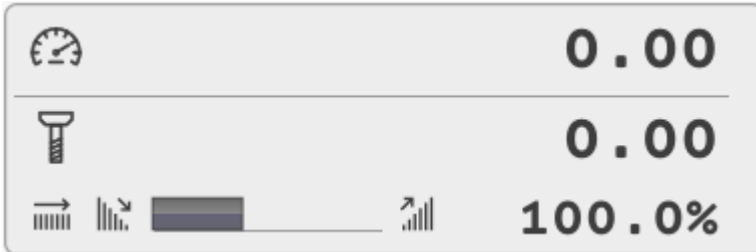

Reset button: Resets any speed override



Decrease button: Decreases speed override value for 10%



Increase button: Increases speed override value for 10%



Mouse cursor can be used to grab and drag the spindle speed override value bar.

Any spindle speed override value other than 100% (100% means no spindle speed override set) will as a result have a coloured spindle button. This way user can quickly see if spindle speed override is being used.

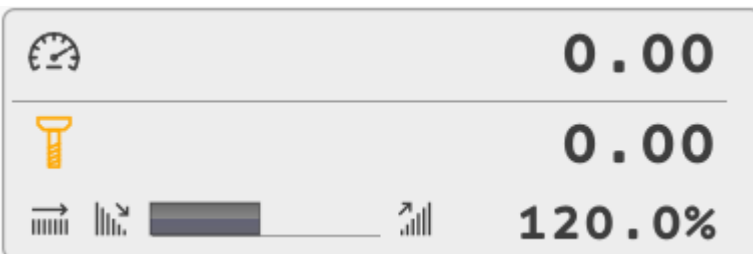

2.3.5 State panel

State panel is used for display of g-code modal states, controller hardware status, parameter value display etc... And as such it can be used as a diagnostic tool in the troubleshooting process.

All data and information described above are available using *state panel tabs*.

By default, PlanetCNC TNG software provides user with two state tabs: *GCode* and *IO*.

User can configure and add up to 30 state tabs.

2.3.5.1 Gcode state tab

GCode tab displays currently active modal states. This tab will register and display modal states executed either from running g-code program or MDI (manual data input).

Gcode tab is divided into: G-codes, M-codes and Other codes.



Active G-code:

Displays all currently active G-codes.

Active M-Codes:

Displays all currently active M-codes.

Other Codes:

Displays all currently active G-codes such as F-word, S-word g-codes and current tool number.

2.3.5.2 IO state tab

IO state tab displays status of controllers hardware input and output pins. As well as E-stop mode status.

Red LED indicates active state, green LED indicates in-active state.

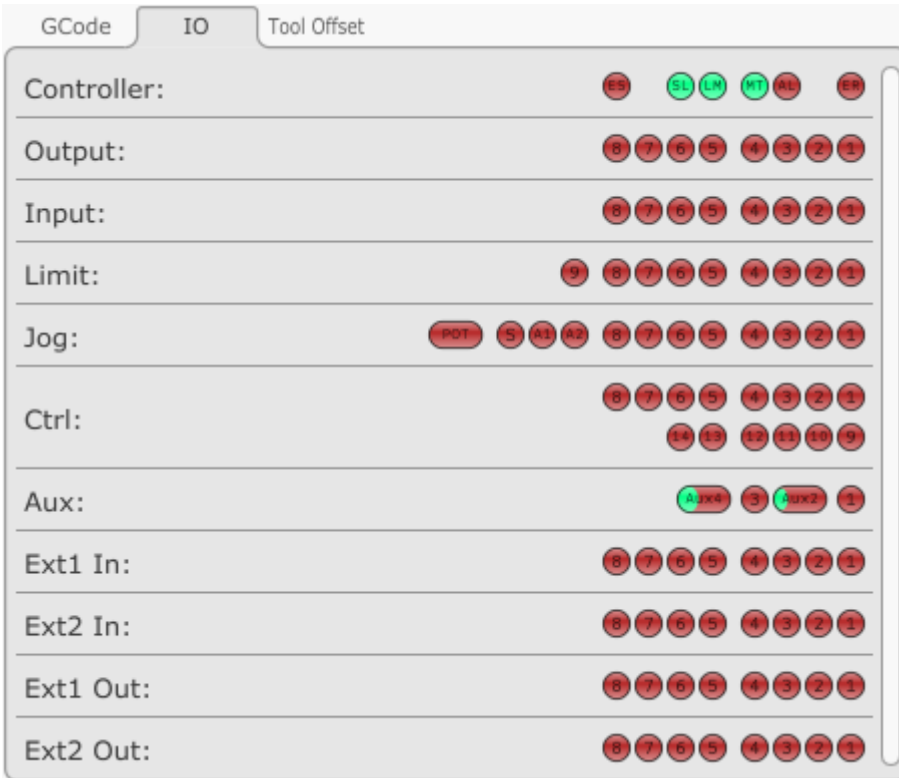

2.3.5.2.1 Controller:



ES:

This is short for E-Stop. This LED indicator lights green when E-Stop mode is active.

SL:

This is short for Soft Limits. This LED indicator lights green when soft limits are enabled via: *Machine/Motors,Limits,Probe/Soft Limits Enable*.



This is short for Limits. This LED indicator lights green when hardware limit switch inputs are enabled via: *Machine/Motors,Limits,Probe/Hard Limits Enable*.



This is short for Motors. This LED indicator lights green when axis motors are enabled via: *Machine/Motors,Limits,Probe/Motors Enable*. When E-stop mode is active, MT LED indicator turns red.



This is short for Axis Lock. This LED indicator lights green when axis is locked due to activated probe. Axis movement is locked at direction at which it was moving when probe was activated. As soon as probe input is inactive, axis lock of dedicated axis is disabled.

Under File/Settings/Jogging user can enable Probe Lock option. When enabled, in order to release the axis lock state, user needs to jog the axis in the opposite direction for short distance.



This is short for Error. This LED indicator lights green when controllers Error input pin is active.

2.3.5.2.2 Output



Output LED panel displays controllers Output header pin status. When output pin is active, corresponding 1-8 LED lights green.

2.3.5.2.3 Input



Input LED panel displays controllers Input header pin status. When input pin is active, corresponding 1-8 LED lights green.

2.3.5.2.4 Limit



Limit LED panel displays controllers Limit header pin status. When limit input pin is active, corresponding 1-9 LED lights green.

2.3.5.2.5 Jog

Jog: 

Jog LED panel displays controllers jog header pin status. When jog input pin is active, corresponding 1-8 LED lights green.

POT:

This LED indicator displays jogging potentiometer input value. POT indicator resembles a progress bar, and depending on potentiometer value (rod position), indicator will display progress of pot. input value – jogging speed.

Potentiometer at 0%:  50%:  100%: 

S:

This is short for Shift. This LED indicator lights green when Shift input is active.

A1, A2:

This is short for alternative. These LED indicators light green when A1 or A2 are active.

2.3.5.2.6 Ctrl

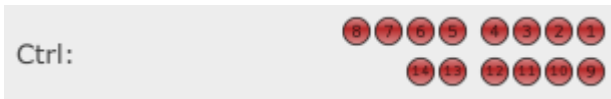

Ctrl LED panel displays controllers CTRL header pin status. When CTRL pin is active, corresponding 1-14 LED lights green.

2.3.5.2.7 Aux

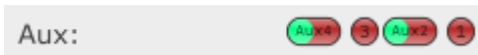

2.3.5.2.8 Ext1 In



Ext1 In LED panel displays controllers EXT header pin status. When EXT pin is active, corresponding 1-8 LED lights green.

2.3.5.2.9 Ext2 In



Ext2 In LED panel displays controllers EXT header pin status. When EXT pin is active, corresponding 1-8 LED lights green.

2.3.5.2.10 Ext1 Out



Ext1 Out LED panel displays controllers EXT header pin status. When EXT pin is active, corresponding 1-8 LED lights green.

2.3.5.2.11 Ext2 Out



Ext2 Out LED panel displays controllers EXT header pin status. When EXT pin is active, corresponding 1-8 LED lights green.

2.3.5.3 User state tabs

User state tabs can be added to state panel. Each tab can include any native system parameter or user created parameter. User can add up to 30 user state tabs.

The screenshot shows a software interface with a top navigation bar containing tabs for 'GCode', 'IO', 'State', 'Position', and 'Mode'. The 'Mode' tab is selected and active. Below the navigation bar, a panel titled 'Modal State' displays a list of parameters and their values:

Modal State	
Motion (R)	800
Units	21
Plane	17
Distance Mode	90
Distance Mode IJK	91.1
Distance Mode ABC	90.2

To the right of the 'Modal State' panel, a dropdown menu is open, listing the following options: Tools, Offset, CS, Home, Jogging, Outputs, THC, Settings, Defaults, Measure, Home, Measure Off, HW, GCode, and UI.

2.3.6 Jogging Panel

Jogging panel offers on-screen jog buttons.

Jogging panel is located under state panel:



by clicking cross-arrow button, jogging buttons will appear:

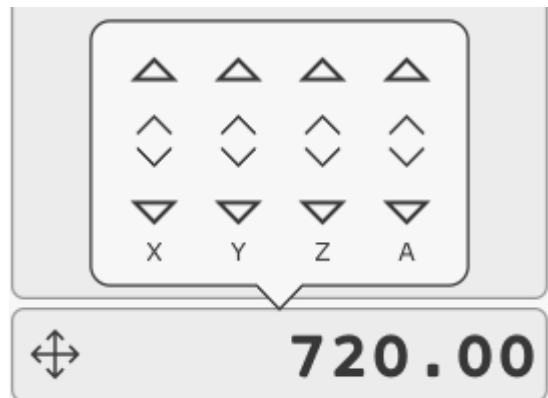

Mouse click+hold on large arrow jog buttons to jog machine in desired direction. Machine will move until the mouse button is released. Corner buttons allow diagonal or combined axis jogging.

Smaller arrows, near the centre of jog controls, perform a single step move per click. Step distance is configurable.

Jogging speed can be set by double clicking on the jogging speed value, *Set* insert field will appear:

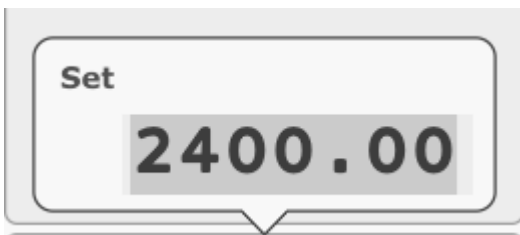

In settings (chapter), user can change jogging panel button layout (XY Cross or UV Cross) as also jog panel display behaviour to either *Hide*, *Show* or *Fixed* (jogging panel is always displayed on main window):

Fixed XY Cross jogging panel layout:

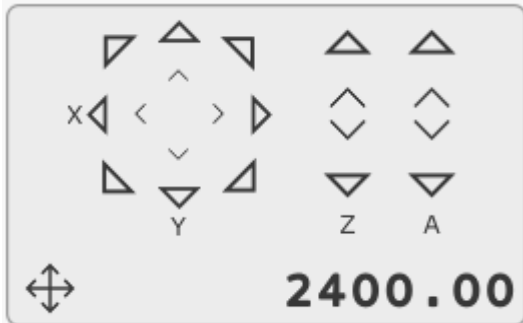

2.3.7 3D program visualization display

Shows 3D display of g-code program.

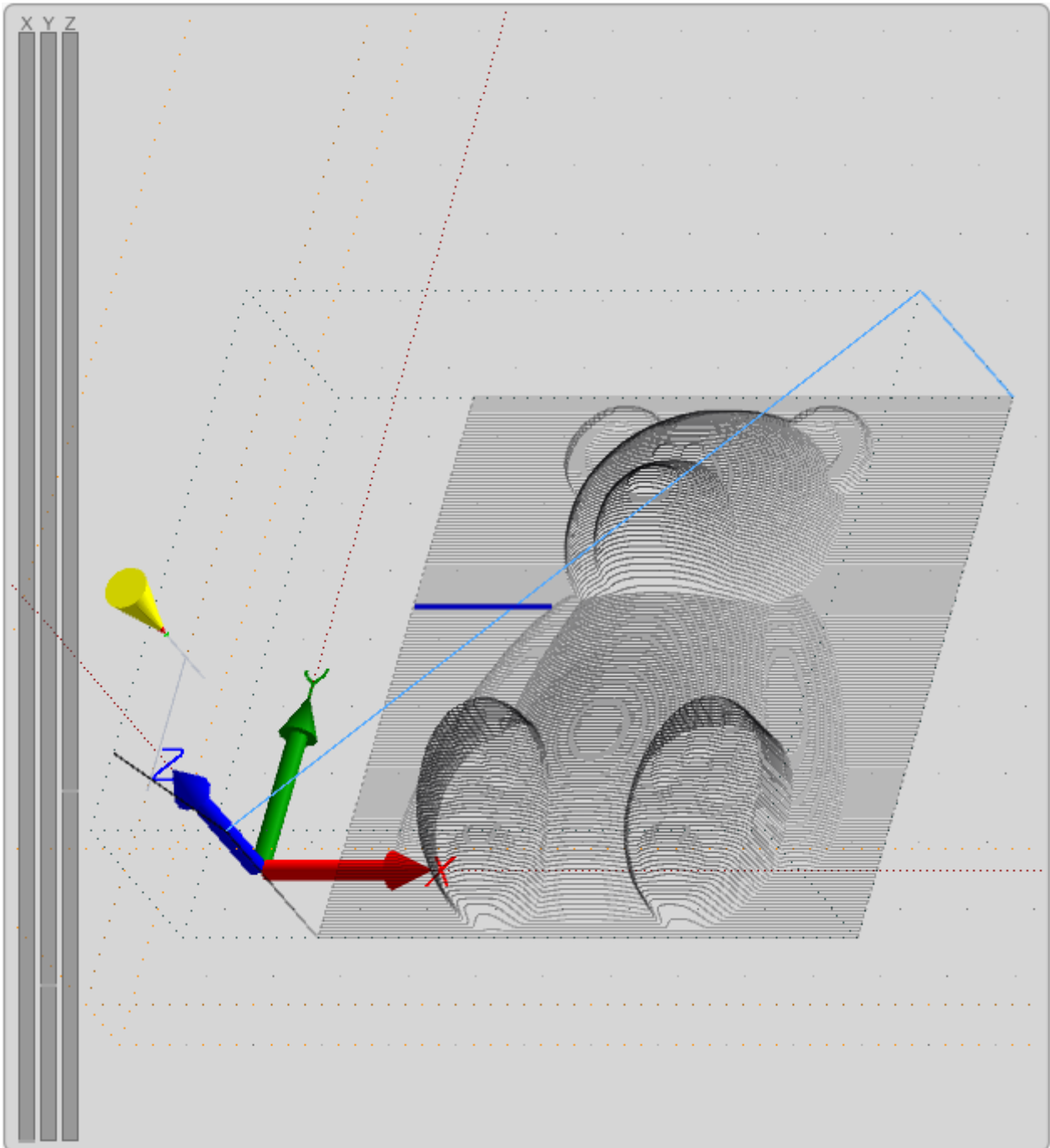

2.3.8 G-Code panel

G-code panel displays and tracks current program g-code lines.

2.3.8.1 Vertical Slider

At the right side of G-code panel is vertical slider. Dragging slider up or down, user is able to navigate through pages of current g-code program.

2.3.8.2 Position Slider

At the bottom of G-Code panel is position slider. Dragging slider left or right, user is able to navigate through program lines and observe progress of toolpath simulation in program visualization display. User can also use PC keyboard arrow keys to navigate through pages of g-code program, line by line.

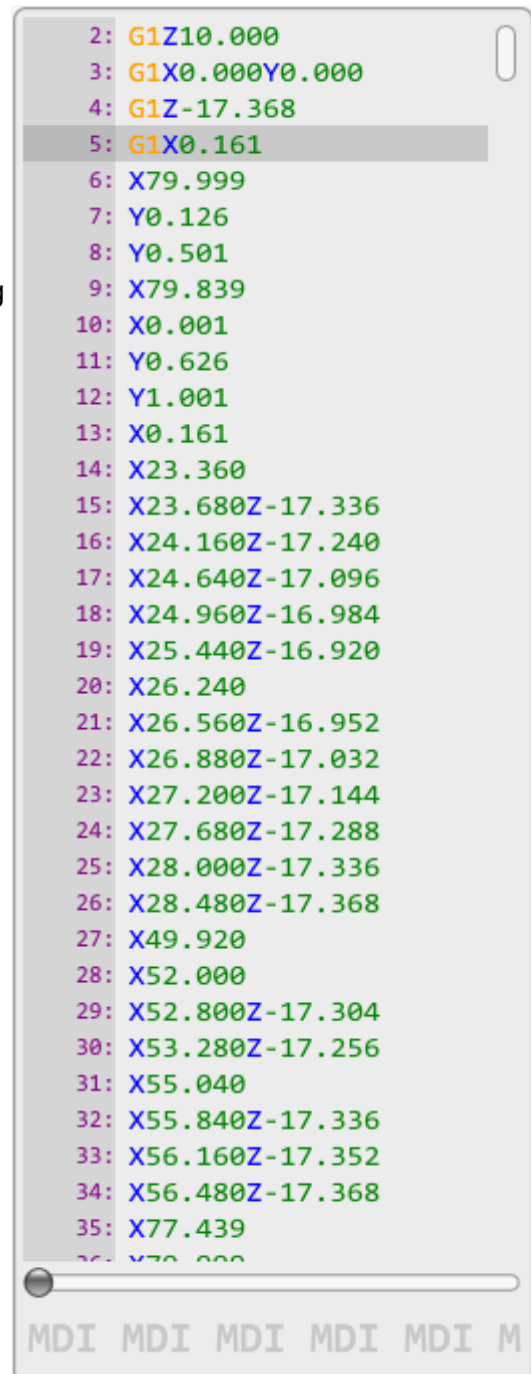

```
2: G1Z10.000
3: G1X0.000Y0.000
4: G1Z-17.368
5: G1X0.161
6: X79.999
7: Y0.126
8: Y0.501
9: X79.839
10: X0.001
11: Y0.626
12: Y1.001
13: X0.161
14: X23.360
15: X23.680Z-17.336
16: X24.160Z-17.240
17: X24.640Z-17.096
18: X24.960Z-16.984
19: X25.440Z-16.920
20: X26.240
21: X26.560Z-16.952
22: X26.880Z-17.032
23: X27.200Z-17.144
24: X27.680Z-17.288
25: X28.000Z-17.336
26: X28.480Z-17.368
27: X49.920
28: X52.000
29: X52.800Z-17.304
30: X53.280Z-17.256
31: X55.040
32: X55.840Z-17.336
33: X56.160Z-17.352
34: X56.480Z-17.368
35: X77.439
36: X70.000
```

MDI MDI MDI MDI MDI M

2.3.8.3 Additional G-code panel options

Right mouse click on selected g-code line opens a dialogue with additional options:

2.3.8.3.1 Start From Selected Line

Program will start at position of selected program g-code line.

2.3.8.3.2 Move/To Selected Line

See chapter 2.6.12.6

2.3.8.3.3 Move To Selected Line XY

See chapter 2.6.12.7

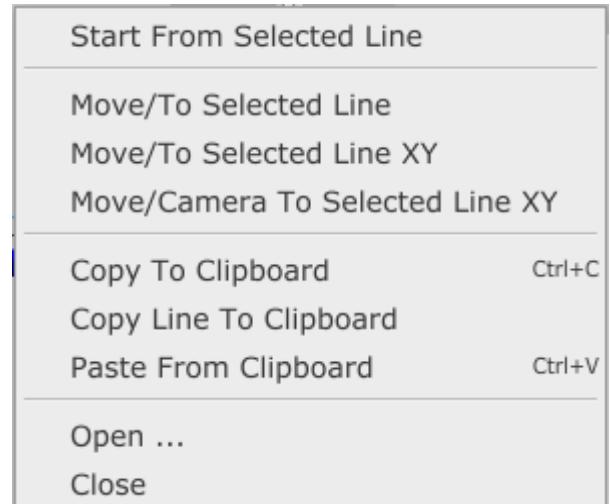

2.3.8.3.4 Move/Camera To Selected Line XY

See chapter 2.6.12.10

2.3.8.3.5 Copy To Clipboard

See chapter 2.5.16

2.3.8.3.6 Copy line to Clipboard

2.3.8.3.7 Paste From Clipboard

See chapter 2.5.17

2.3.8.3.8 Open...

See chapter 2.3.2

2.3.8.3.9 Close

See chapter 2.3.1

2.3.9 Utilities panel

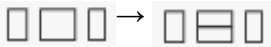
Utilities panel is shown/hidden with centre button for panel layout manipulation. When utilities panel is displayed, centre button will change its symbol: 

By default, Utilities panel embeds only *Output* tab. User can additionally embed also *Edit*, *Camera* and *Log* tabs to the utilities panel. This is done in settings (*Chapter xxxxx*).

Please note: Edit, Camera and Log tabs will not be embedded until you execute them from their dedicated menus.

2.3.9.1 Output tab

Output tab will display any error event and data used with *print* command.

In a case of g-code error, exact program line where error occurs, current g-code program folder path and the error definition will be displayed.

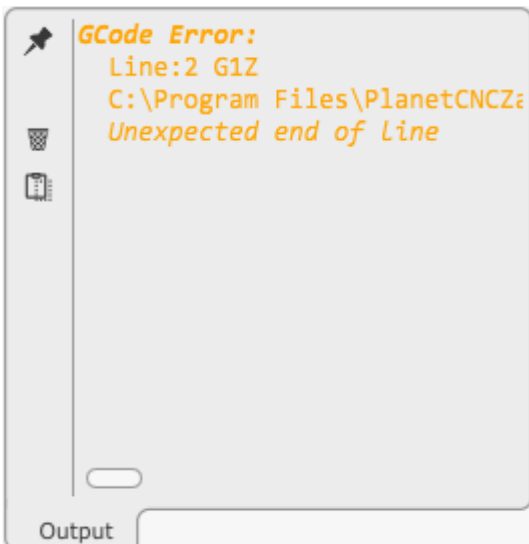

Bottom picture depicts output data of print command: *(print,#<_x>); position value of X axis*



2.3.9.1.1 Output tab buttons

Output tab uses three buttons for easier data manipulation:



Pin:

Pin button will stick/fix last printed data so that it is always visible as a last displayed line. Basically this is an automatic scroller, always tracking last printed data.

It is very useful if there is large and frequent flow of printed data.



Clear:

Clears any printed data on the output tab display.



Copy:

Copies any printed data to clipboard.



2.3.9.2 Edit tab

It is used as g-code program editing tool, where user can create new or edit current g-code program.

Edit tab will be populated with currently imported g-code program as soon as *Program/Edit* menu item is executed. User then has a full control on editing or re-writing g-code program.

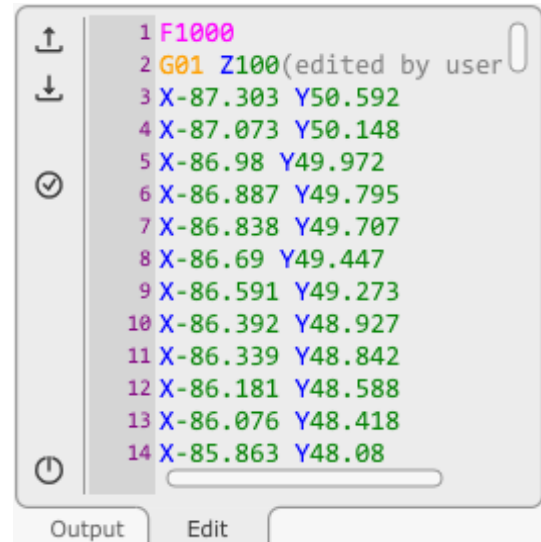

2.3.9.2.1 Edit tab buttons

Output tab uses four buttons for easier program editing and and tab control.



Upload:

This buttons uploads any content in edit tab into g-code panel.

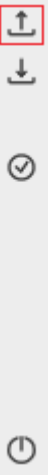

Download:

This button copies any content (g-code program) from g-code panel and pastes it to edit tab.

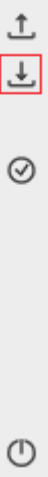

Verify:

This button will verify any content in edit tab. Any g-code syntax or initialization error will be displayed.

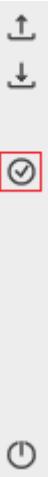

Example of displayed error in G-code after using verification button:

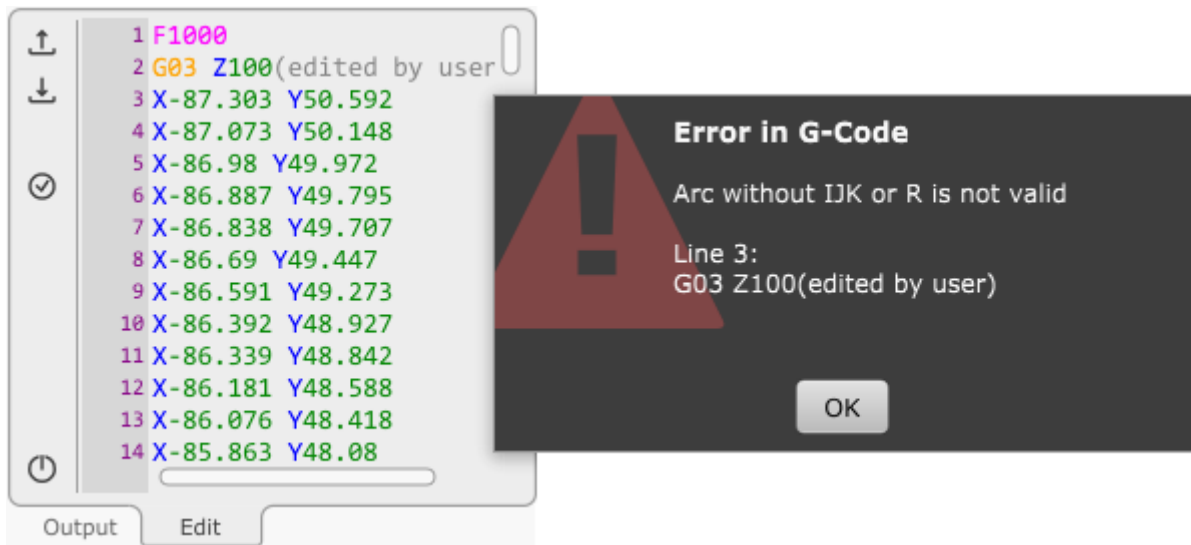

Close:

Closes edit tab.



2.3.9.3 Log tab

Log tab will display all information regarding computer, connected USB and USB HID devices and connected controller.

This screenshot shows the 'Computer' log tab. A yellow callout box labeled 'Computer' points to the computer icon in the left sidebar. The main area displays system information in a text-based format:

```

Language:          sl (en-US)
User is admin:    yes
Settings are R/W: yes

CPU:
Model:            GenuineIntel
                  Intel(R) Core(TM) i7 CPU           870  @ 2.93GHz
Physical CPUs:    4
Logical CPUs:     8
Speed:            2931 MHz

Memory:           4095 MB

OpenGL:
Vendor:           ATI Technologies Inc.
Renderer:         ASUS EAH5570 series
Version:          4.1.10834 Compatibility Profile Context
Extensions:       GL_AMDIX_debug_output GL_AMDIX_vertex_shader_tesse
    
```

At the bottom, there are two tabs: 'Output' and 'Log', with 'Log' being the active tab.

This screenshot shows the 'USB' log tab. A yellow callout box labeled 'USB' points to the USB icon in the left sidebar. The main area displays a list of USB devices with their identifiers and speeds:

```

USB devices:
VID: 0x1033 PID: 0x0194 (1)
VID: 0x8086 PID: 0x3b34 (2)
VID: 0x8087 PID: 0x0020 (2.1) Speed:480 Mbit/s (USB HighSpeed)
VID: 0x046d PID: 0xc31c (2.1.1) Speed:1.5 Mbit/s (USB LowSpeed), HID
VID: 0x046d PID: 0xc069 (2.1.2) Speed:1.5 Mbit/s (USB LowSpeed), HID
VID: 0x0409 PID: 0x005a (2.1.3) Speed:480 Mbit/s (USB HighSpeed)
! VID: 0x2121 PID: 0x2130 (2.1.3.4) Speed:480 Mbit/s (USB HighSpeed), N
VID: 0x0922 PID: 0x0020 (2.1.4) Speed:12 Mbit/s (USB FullSpeed)
VID: 0x0409 PID: 0x005a (2.1.5) Speed:480 Mbit/s (USB HighSpeed)
VID: 0x1908 PID: 0x2311 (2.1.5.4) Speed:480 Mbit/s (USB HighSpeed)
VID: 0x8086 PID: 0x3b3c (3)
VID: 0x8087 PID: 0x0020 (3.1) Speed:480 Mbit/s (USB HighSpeed)
VID: 0x0bda PID: 0x0306 (3.1.4) Speed:480 Mbit/s (USB HighSpeed)
    
```

At the bottom, there are two tabs: 'Output' and 'Log', with 'Log' being the active tab.

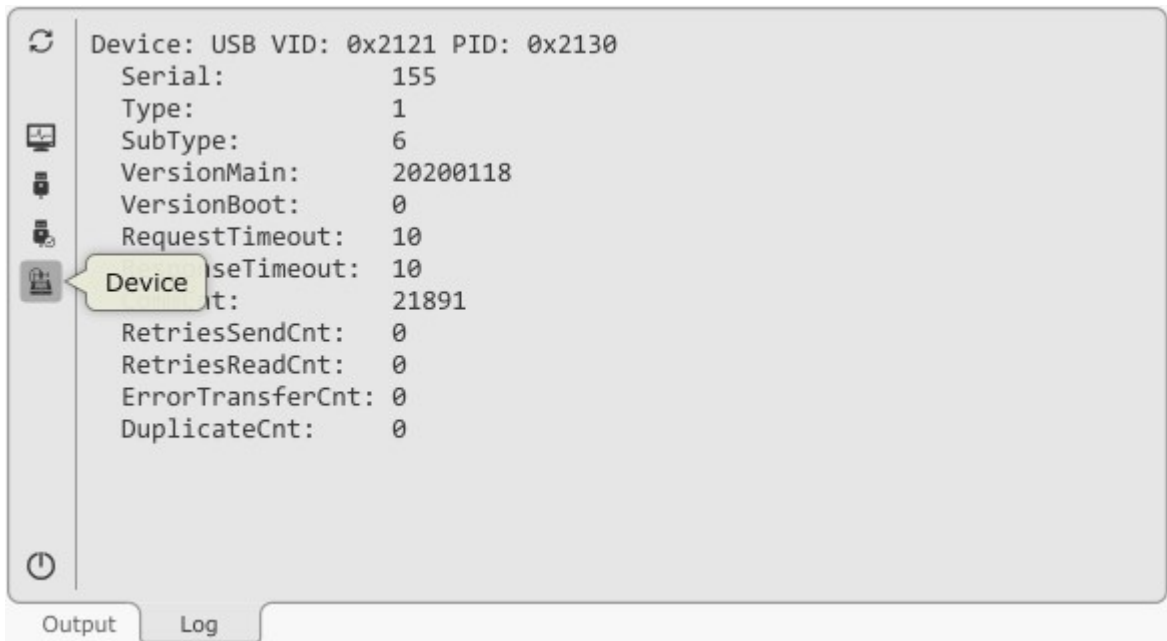
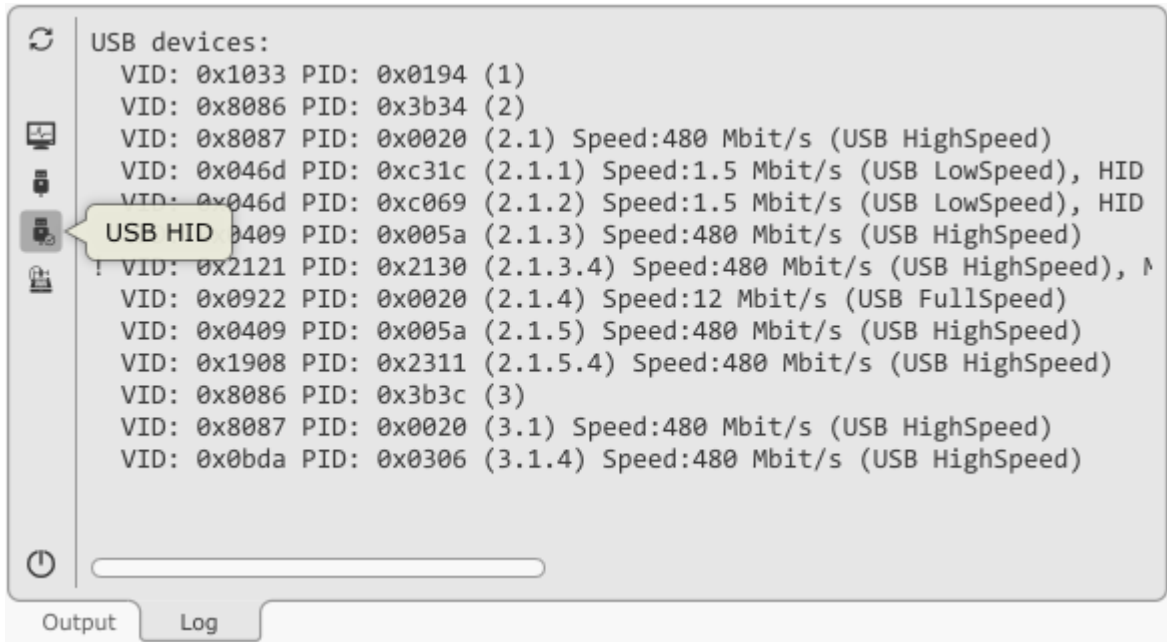

2.3.9.4 Camera tab

Camera tab provides docked view from connected USB camera.

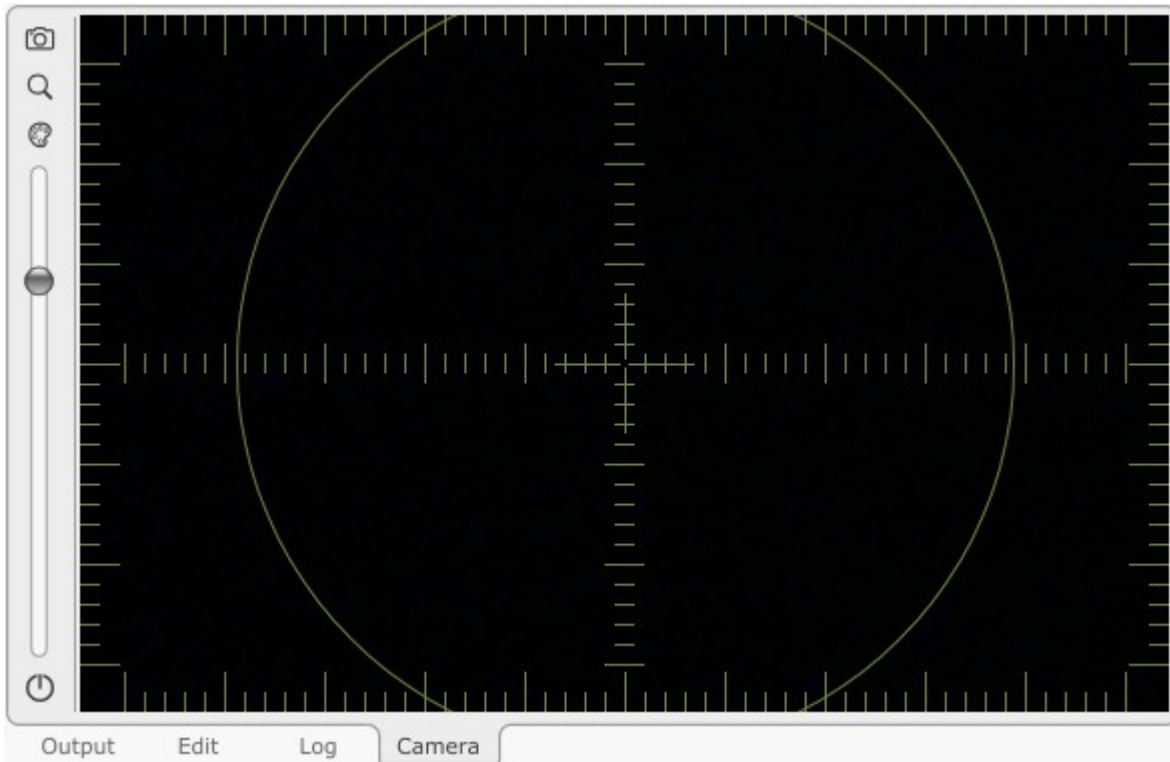

2.3.9.4.1 Camera tab buttons

Camera tab uses buttons for manipulation of camera window.



Camera:

User can select camera from the list of available USB cameras.

Example:



Zoom:

User can select zoom factor of camera view.

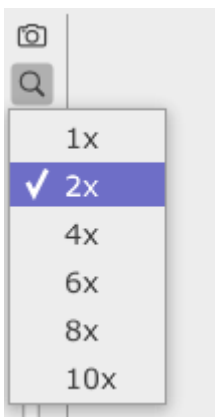

Colour:

This button opens colour palette dialogue which allows user to change and set colour of camera view cross-hairs.



Example:

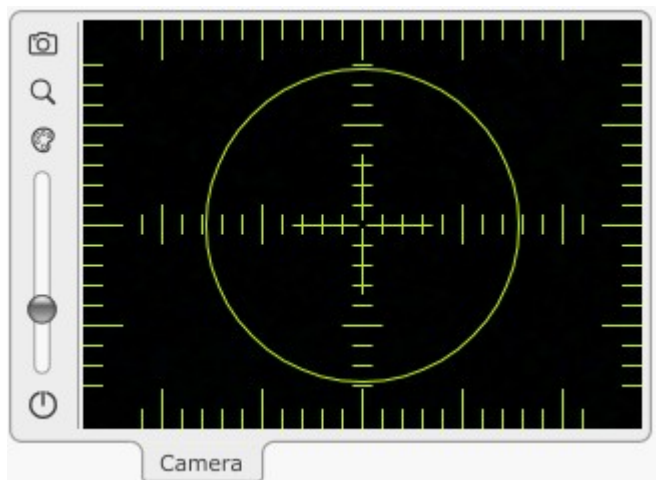
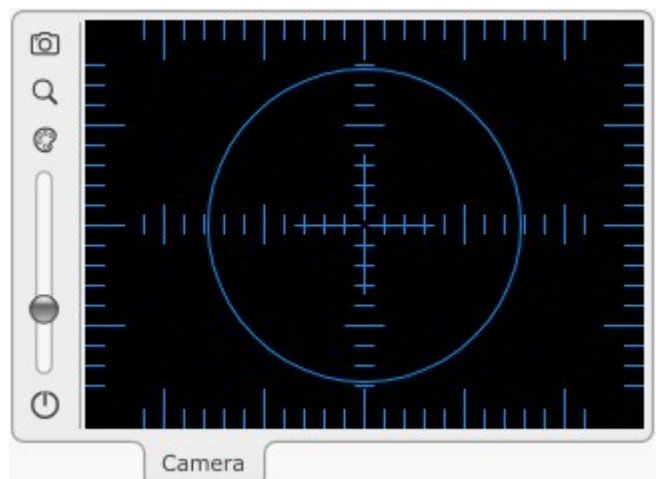
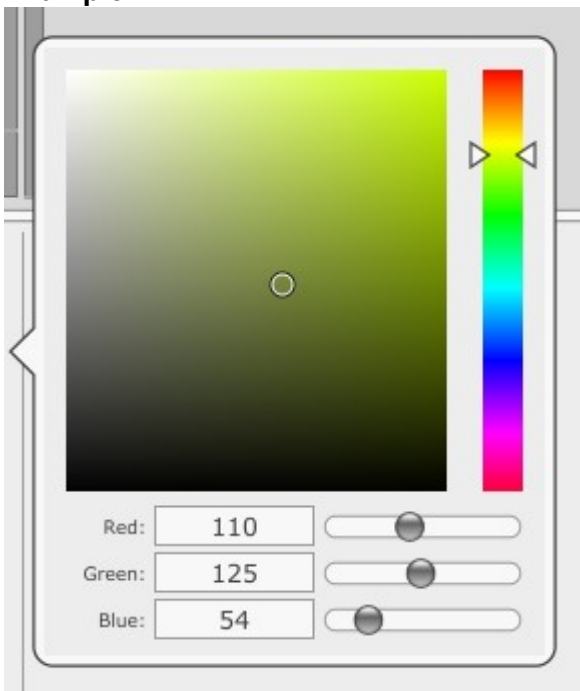

Slider:

With slider button, user is able to adjust the diameter of a circle of camera view. This comes very useful in the procedure of capturing points for the needs of transformation.

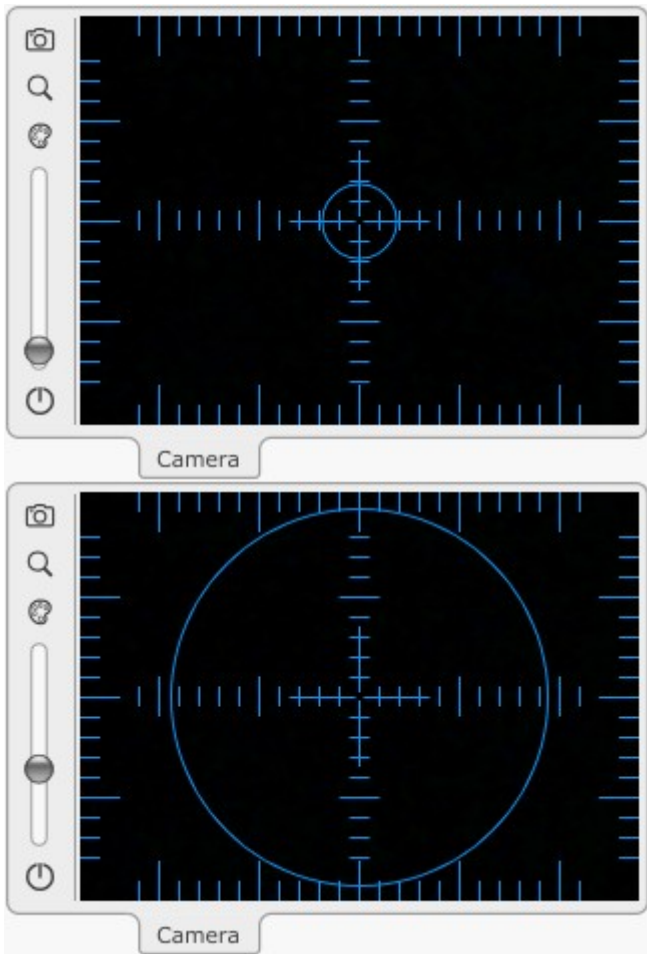

Close:

Closes camera tab



2.3.10 Manual data input (MDI) window

MDI window allows user of manual G-code input and execution of MDI shortcuts.

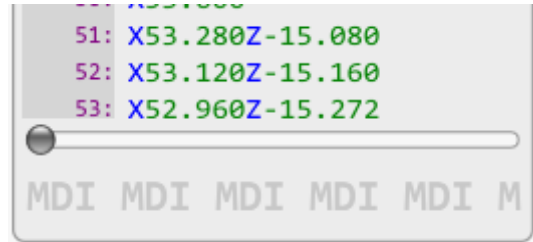

Example (manual G-code input):

Typing G53 X0 Y0 Z10 will move machine to its absolute position of X0 Y0 Z10.

```
G00 X[15+2] Y[2*10]
```

The MDI window can also be used for execution of shortcuts using MDI codes(see chapter 2.8.3.23.3).

Example (MDI code):

```
/Log
```

In settings, shortcut MDI code named *Log* was set for *Show Log* action.

Typing */Log* into MDI window will open *Show Log* dialog.

Please note: Symbol “/” before MDI code needs to be used.

Line break can be created with keyboard key combination *Shift+Enter*. This way user can input multi-line g-code command:

```
F1500
G01 X50 Y70
M3 S10000
G01 Z-5|
```

Example (Expression Evaluator):

MDI window also offers expression evaluator option.

```
=2+3*5
```

Result is displayed under Output window:

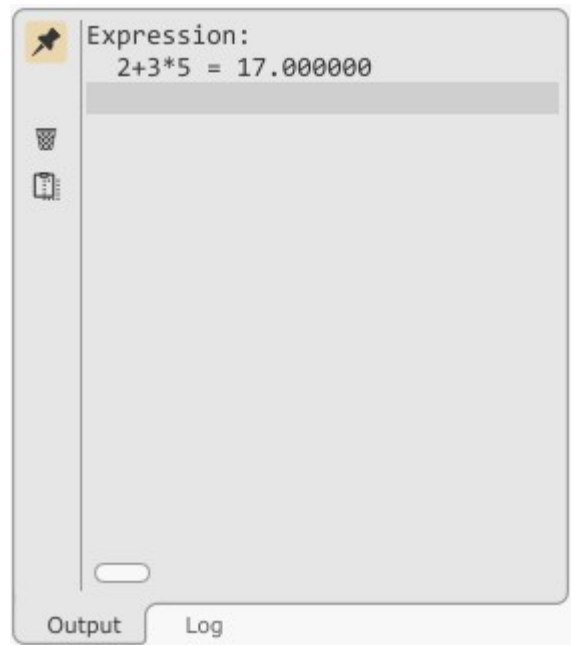

2.3.11 Indication Light

Connectivity indication light is located at the bottom right corner of main window. It indicates controller status regarding connection with PlanetCNC TNG software and license activation.

2.3.11.1 *Indication light colour description:*

Green indication light with S (simulation): 

Indicates that simulation mode is selected and enabled in settings.

Indication light with X (no license): 

PlanetCNC TNG software does not find proper license for connected controller. Make sure that your PlanetCNC TNG license is valid and correctly imported.

The colour of indication light can be either gray, green or orange.

Green indication light: (firmware version and license OK): 

Indicates that controllers firmware is updated with correct PlanetCNC TNG software version and controller license is activated, meaning, license is found and validated by software.

Orange light (firmware version mismatch): 

Indicates that controllers firmware version is not updated with PlanetCNC TNG software version that you are using it with. Update controllers firmware: Machine/Controller/Firmware Update

Gray light with S: 

Indicates that simulation mode is not enabled.

Red light with status bar: 

Indicates that software is processing motion commands and is sending them to controller.

2.4 File menu

File menu offers a group of methods for opening, importing and exporting of machine programs.

Programs can be used for visualization, simulation, generating toolpath and can be in various formats.

Import features display user dialogues for entry of user parameters. Description of features is provided below.

G-Code can be exported using an option best suited to user requirement.

'Settings' is where we configure and set machines main parameters.

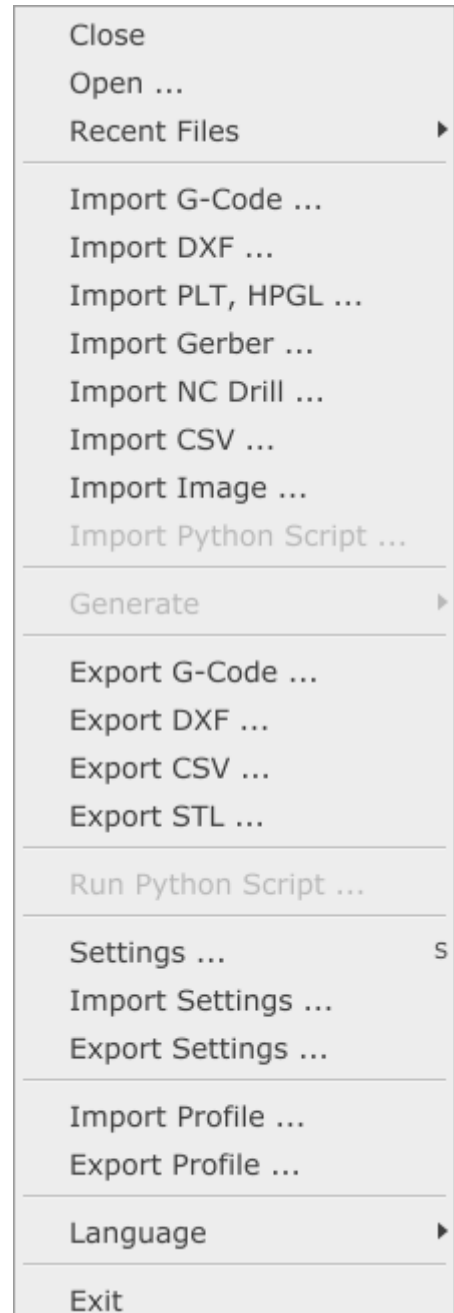

2.4.1 Close

Closes program that is currently opened.

2.4.2 Open

Opens new program. Software will try to auto detect file format.

Example: If you want to open .dxf file, TNG software will automatically recognize the DXF file format and launch DXF import dialogue.

2.4.3 Recent files

Displays a list of recently opened programs. Select file for open from a drop-down list.

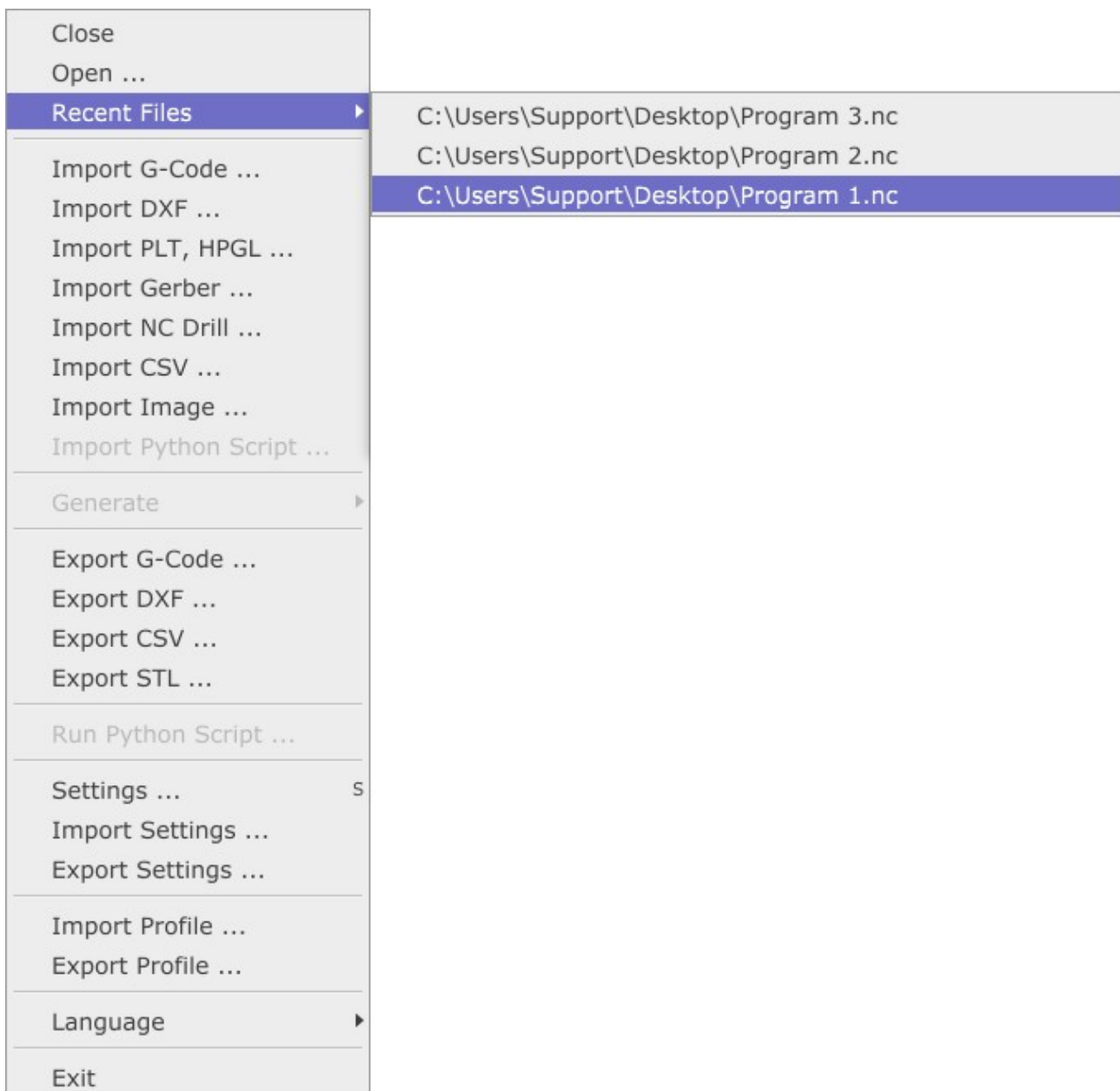

2.4.4 Import G-code

Opens program in G-code form. G-code file can use different extensions. Usually extensions are: *.nc, *.tap, *.cnc, *.iso, *.gcode, *.ncf, *.txt.

2.4.5 Import DXF...

and

2.4.6 Import PLT, HPGL...

Imports program in DXF and PLT/HPGL format. Most software's for CAD drawing or vector images have option to save design in DXF format. These types of format usually contain vectors, that can be converted to toolpath.

PlanetCNC TNG software will automatically generate toolpath g-code program based on your imported DXF file.

When using **Import DXF** feature, user dialog will be displayed. User has option to configure program parameters to suit his machining needs.

The screenshot shows a dialog box titled "DXF" with a close button (X) in the top right corner. The dialog is organized into several sections:

- Units:** Radio buttons for Metric (mm) and Imperial (in).
- Scale:** A text input field with "1.000" and increment/decrement buttons (-/+).
- Origin:** Two sets of radio buttons for selecting the origin point.
- Loops:** A text input field with "1" and increment/decrement buttons (-/+).
- Interpolate:** button.
- Sort:** button.
- Feed Speed:** A text input field with "1500.0" and increment/decrement buttons (-/+).
- Plunge Speed:** A text input field with "100.0" and increment/decrement buttons (-/+).
- Tool Change:** button and **Offset:** button.
- Outputs:** Spindle, Flood, and Mist. The Spindle output has a text input field with "24000.0" and increment/decrement buttons (-/+).
- Mode:** Radio buttons for 3D and 2D. Below 2D are UVW, ZXY, and YZX.
- Height:** Safe Height: Enable. Below are text input fields for Height (5.000), Start Height (0.000), Step Down (0.000), and Cut Height (0.000), each with increment/decrement buttons (-/+).
- Height Section:** Enable. Below are text input fields for Distance (0.000) and Size (0.000), each with increment/decrement buttons (-/+).
- Tangent Knife:** Enable.
- Bottom - Off:** Radio buttons for Spindle, Flood, Mist, and Pause. Below is a text input field for Delay (0.0) with increment/decrement buttons (-/+).
- Top - Off:** Radio buttons for Spindle, Flood, Mist, and Pause. Below is a text input field for Delay (0.0) with increment/decrement buttons (-/+).
- Top - On:** Radio buttons for Spindle, Flood, Mist, and Pause. Below is a text input field for Delay (0.0) with increment/decrement buttons (-/+).
- Bottom - On:** Radio buttons for Spindle, Flood, Mist, and Pause. Below is a text input field for Delay (0.0) with increment/decrement buttons (-/+).
- Enable Scripts:** button.
- Buttons:** OK and Cancel buttons at the bottom right.

2.4.6.1 Units

You can set units as **Metric(mm)** or **Imperial (in)** for your DXF design. You can fine tune your units using *Scale* option.

2.4.6.2 Scale

Sets scale of your imported DXF design. This comes handy when you need your toolpath to be re-sized or some other units are used.

E.g.: If you DXF design is drawn in centimetres (cm) then select *Units* as *Metric* and set *Scale* to 10.

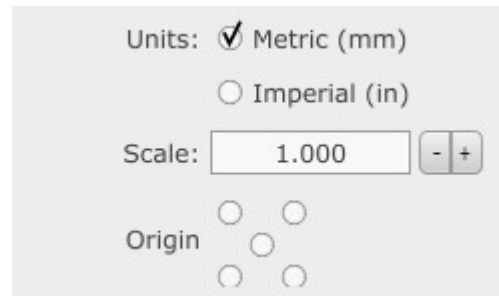

2.4.6.3 Origin

Example:

Let say we import DXF file of which we do not know its absolute XY 0,0 coordinates.

Generated toolpath will be positioned accordingly, but not necessarily in a way that would suit us :

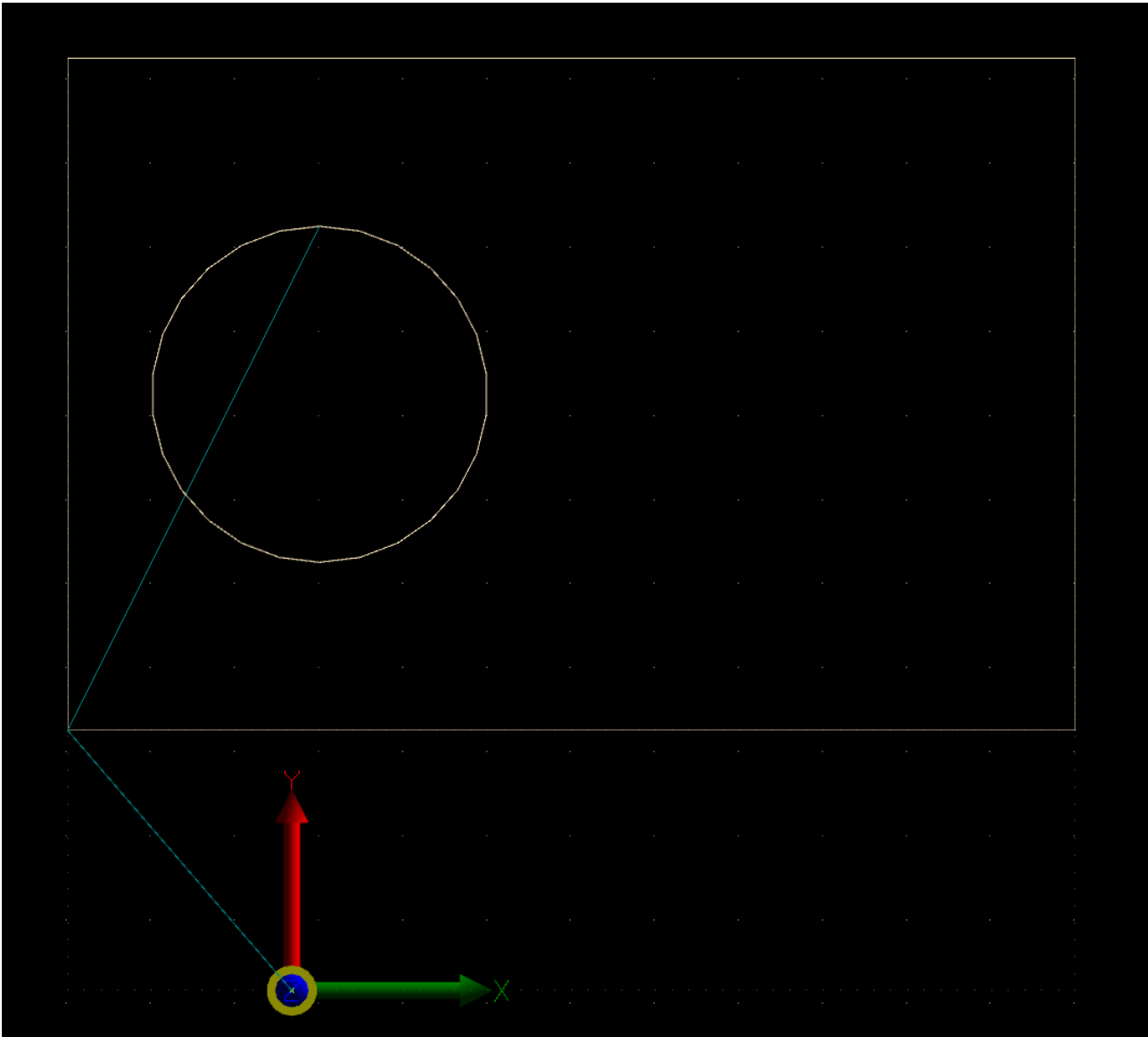

Generated toolpath is positioned in relation to its absolute XY 0,0 coordinates (the way it was drawn). But what if we want that toolpath extents are aligned with working position XY0,0?

For this purpose you can use one of five options under *Extents*:

-Bottom left :



-Top Left:



-Center:



-Bottom right:



-Top right:



Example:



Bottom Left:

With this option enabled, toolpath XY0,0 point will be aligned with our working offset XY0,0:

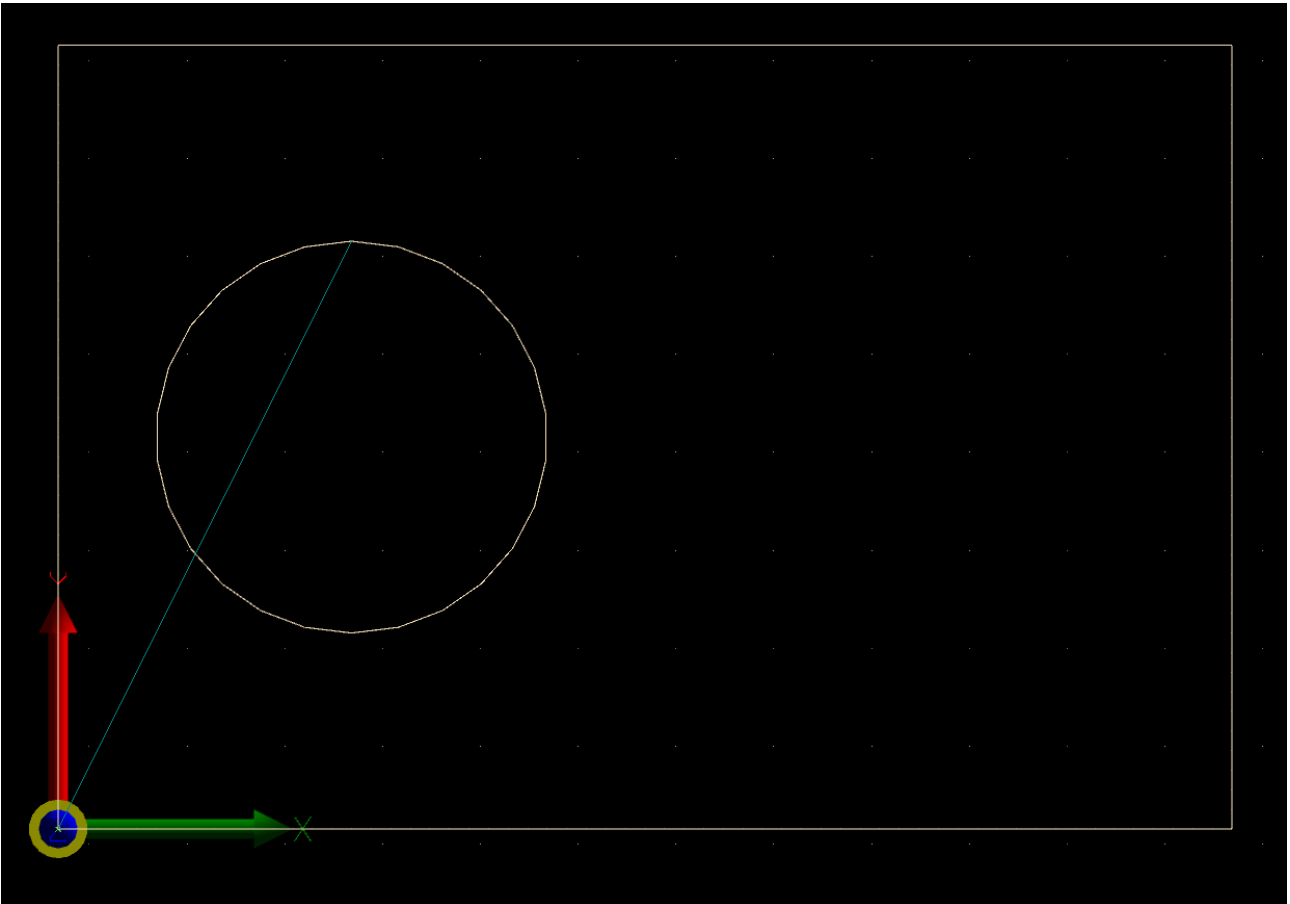

Center:



With this option enabled, toolpath center point will be aligned with our working offset $XY0,0$:

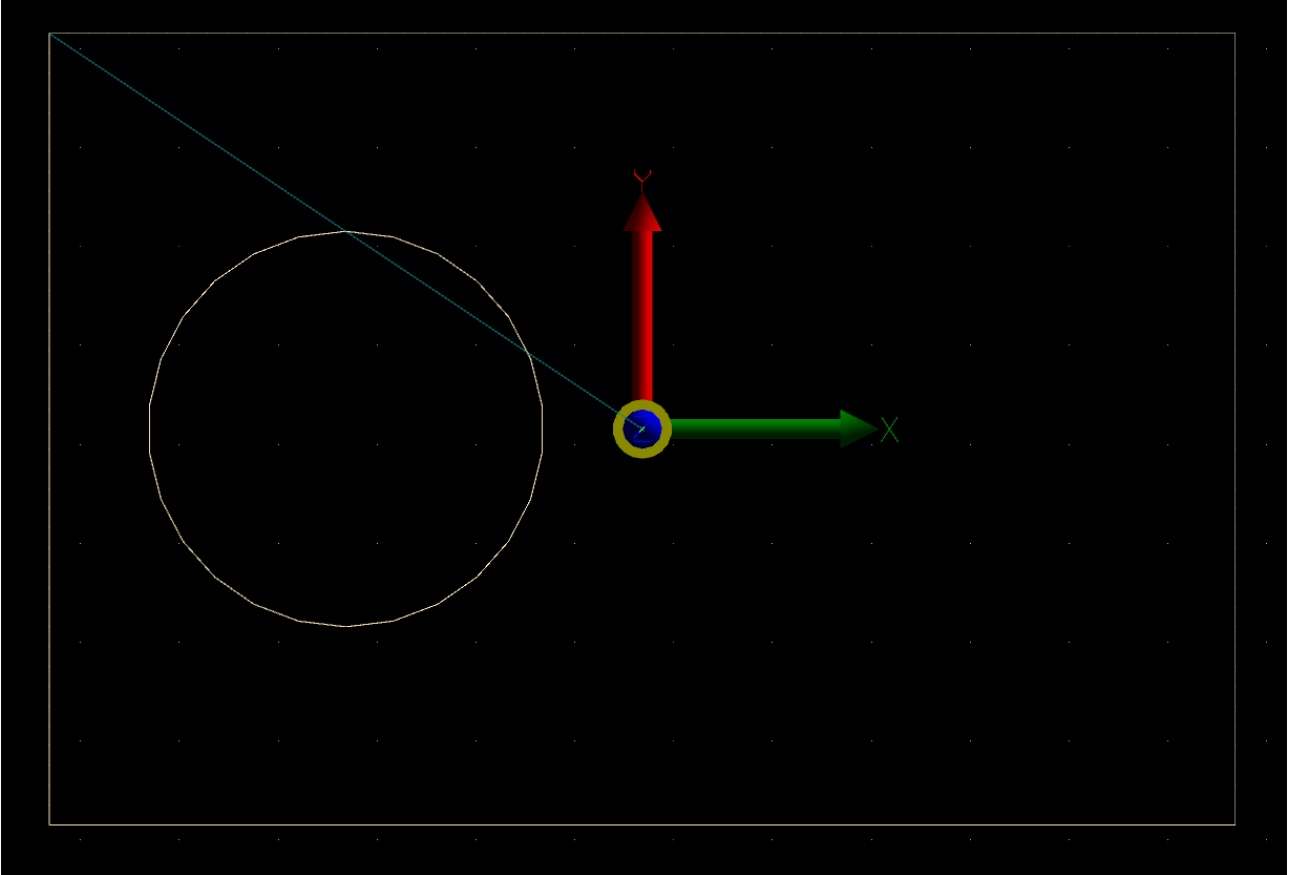

2.4.6.4 Loops

You can set number of loops of your program. Each generated toolpath pass will be repeated for inserted value of loops.

Example: If you insert *Loop:3*, pass will be repeated for 3 iterations.



The screenshot shows two settings: 'Loops' with a text input field containing the number '1' and a numeric spinner control to its right, and 'Interpolate' with a checked checkbox.

2.4.6.5 Interpolate

If your DXF file contains elements such as circles, arcs etc.. you can interpolate these elements into short lines by enabling *Interpolate* option.

2.4.6.6 Sort

Sorts elements of the DXF file, and optimizes generated toolpath.

2.4.6.7 Feed Speed

Sets feed speed for generated toolpath. F-word g-code will be generated. Each feed move will be performed at this speed.

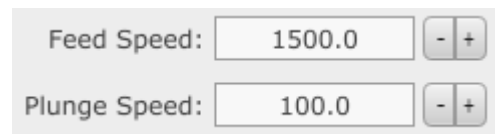

The screenshot shows two settings: 'Feed Speed' with a text input field containing '1500.0' and a numeric spinner control to its right, and 'Plunge Speed' with a text input field containing '100.0' and a numeric spinner control to its right.

2.4.6.8 Plunge Speed

Set feed speed of plunge moves for generated toolpath. Each feed move in Z- direction (plunge) will be performed at this speed.

2.4.6.9 Tool change and Offset



The screenshot shows two settings: 'Tool Change' with a checked checkbox and 'Offset' with a checked checkbox.

Tool change:

Generated program will include tool change commands (Tn M6) if DXF file uses layers.

Each layer number will represent dedicated tool number in generated program.

Offset:

Tn M6 and G43 Hn g-codes will be generated for specified tool(layer).

Offset value will be taken from tool table.

2.4.6.10 **Outputs**

Generated program will include *M3/M5;M7,M8/M9* spindle and coolant g-code commands, depending on options selected.

Please note: If DXF file uses layers then outputs will be turned ON at beginning and turned OFF at end of layers toolpath.

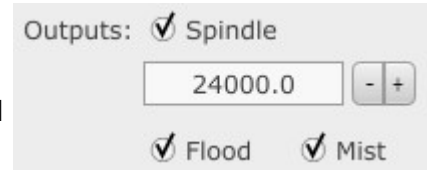

Outputs: Spindle
24000.0 - +
 Flood Mist

Spindle:

With this option enabled, generated program will include M3/M5 g-codes.

If layers are used in DXF file, layers toolpath will include M3 g-code at start and M5 g-code at the end.

If no layers are used in DXF design, spindle g-codes will be generated only at the beginning of program and at the end.

Flood:

With this option enabled, generated program will include M7/M9 g-codes.

If layers are used, layers toolpath will include M7 g-code at the start and M9 g-code at the end.

If no layers are used, Flood g-codes will be generated only at the beginning of program and at the end.

Mist:

With this option enabled, generated program will include M8/M9 g-codes.

If layers are used, layers toolpath will include M8 g-code at the start and M9 g-code at the end.

If no layers are used, Mist g-codes will be generated only at the beginning of program and at the end.

2.4.6.11 **Import DXF function library:**

Import DXF script code is consisted from functions, each responding to specific event of the DXF Import motion sequence configuration. Some of these events are Z axis moves for which we can set custom behavior.

```
function onImportMoveUp()
```

```
function onImportHeader(filename)
```

```
function onImportFooter()
```

function onImportMoveUp()

function onImportMoveDown()

function onImportMoveTraverse(x, y, z, a, b, c, u, v, w)

function onImportMoveFeed(x, y, z, a, b, c, u, v, w)

function onImportMoveArc(x, y, z, i, j)

function onImportLayerChange(layername, layertoolnumber, layertooldiameter)

2.4.6.12 Mode

Your DXF design can be in 2D or 3D. If **2D** mode is selected, *Height* options will be enabled and you will be able to configure height cutting parameters of generated toolpath (see *chapter 2.4.6.14*).



If **3D** mode is enabled, Height options will be disabled since it is assumed that are already defined in original DXF (however, Safe Height option is available).

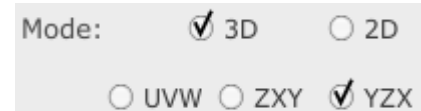

3D mode enables translation of g-code from conventional XYZ plane to UVW, ZXY or YZK plane:

XYZ->UVW

With this option selected, generated g-code program will translate XY coordinates to UV coordinates. This feature is useful for foam cutters, where second tower uses UV coordinates for its motion.

```
G01 X28.573216 Y59.949042 U28.573216 V59.949042 F1500.0
G01 X27.153703 Y59.796429 U27.153703 V59.796429
G01 X25.748694 Y59.542937 U25.748694 V59.542937
G01 X24.365349 Y59.189859 U24.365349 V59.189859
G01 X23.010716 Y58.738994 U23.010716 V58.738994
G01 X21.6917 Y58.19264 U21.6917 V58.19264
G01 X20.41502 Y57.55358 U20.41502 V57.55358
G01 X19.187184 Y56.825071 U19.187184 V56.825071
G01 X18.014447 Y56.010825 U18.014447 V56.010825
```

XYZ->ZXY

With this option selected, generated g-code program will be in ZX plane. XYZ coordinates from DXF will be translated to ZXY.

```
G01 X59.949042 Z28.573216 F1500.0
G01 X59.796429 Z27.153703
G01 X59.542937 Z25.748694
G01 X59.189859 Z24.365349
G01 X58.738994 Z23.010716
G01 X58.19264 Z21.6917
G01 X57.55358 Z20.41502
G01 X56.825071 Z19.187184
G01 X56.010825 Z18.014447
```

XYZ->YZX

With this option selected, generated g-code program will be in YZ plane. XYZ coordinates from DXF will be translated to YZX.

```
G01 Y28.573216 Z59.949042 F1500.0
G01 Y27.153703 Z59.796429
G01 Y25.748694 Z59.542937
G01 Y24.365349 Z59.189859
G01 Y23.010716 Z58.738994
G01 Y21.6917 Z58.19264
G01 Y20.41502 Z57.55358
G01 Y19.187184 Z56.825071
G01 Y18.014447 Z56.010825
```

2.4.6.13 Height

2.4.6.13.1 Safe Height

As mentioned in the beginning, when 2D mode is used, then *Height* parameters can be set.

Safe height is a safety feature which helps with prevention of machine crashing into obstacles that may interfere with machines toolpath. Obstacles could be screws, fixtures, vises etc..

When machine is finished with cutting toolpath A, it will ascend to safe height and move to next cutting location of toolpath B.

With this option enabled, generated toolpath will include traverse moves performed at safe height.

Height:

Safe Height: Enable

- +

Start Height: - +

Step Down: - +

Cut Height: - +

Toolpath without safe height:

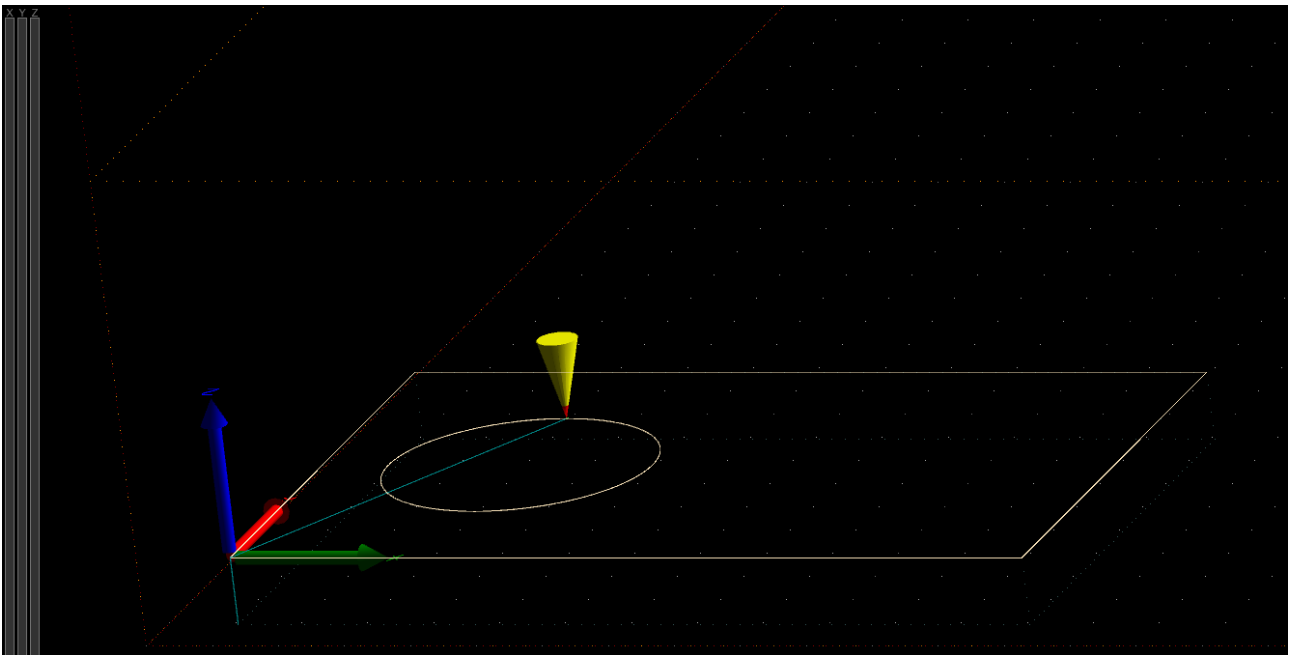

Toolpath with safe height(notice the green traverse toolpath):

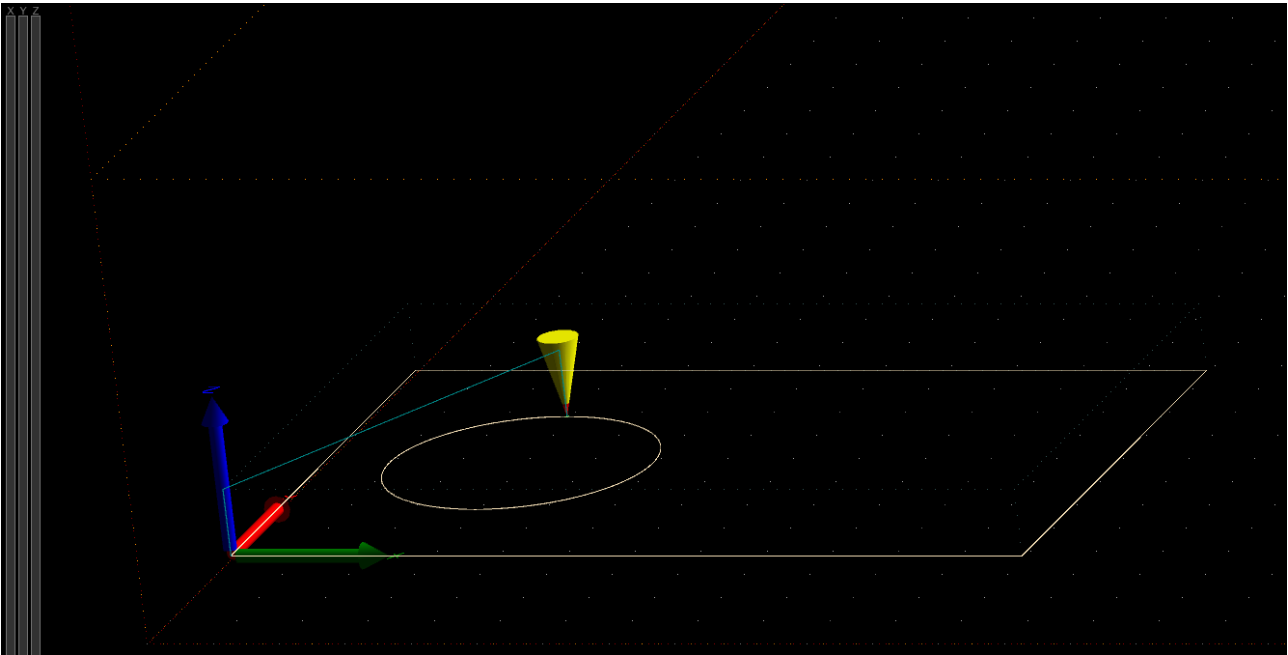

2.4.6.13.2 Start Height

Start height is usually surface of workpiece material. To this height, machine will descend at traverse rate.

2.4.6.13.3 Step Down

Depth of first cutting pass. Each new cutting pass will be deeper for this value. To this height, machine will descend at plunge rate.

2.4.6.13.4 Cut Height

Deepest cutting depth that machine will cut at.

NOTE: Software will automatically calculate number of passes to achieve "Cut Height" depth at "Step Down" value per pass.

Example:

Let's say we want to cut out a square out of a solid wooden block of thickness 30mm.

We would like to cut in passes, with each pass being 4mm deeper than the previous one. To successfully cutout our square, deepest cut should be performed at 31mm.

Set work position Z = 0 is at surface of wooden block.

Start Height = 0

Step Down = -4

Cut Height= 31

Height:		
Safe Height:	<input checked="" type="checkbox"/> Enable	
	<input type="text" value="5.000"/>	<input type="button" value="-"/> <input type="button" value="+"/>
Start Height:	<input type="text" value="0.000"/>	<input type="button" value="-"/> <input type="button" value="+"/>
Step Down:	<input type="text" value="-4.000"/>	<input type="button" value="-"/> <input type="button" value="+"/>
Cut Height:	<input type="text" value="-31.000"/>	<input type="button" value="-"/> <input type="button" value="+"/>

Bottom picture displays side view of generated toolpath based on parameter configuration described above:

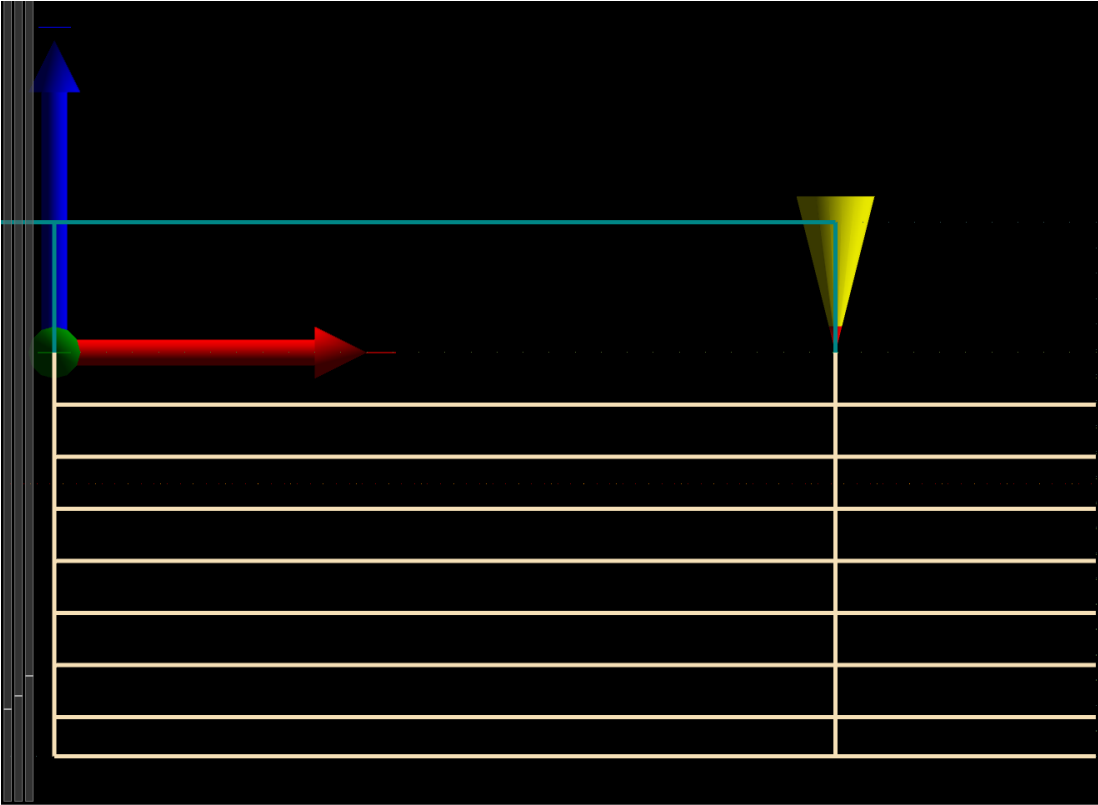

2.4.6.14 Tabs

Tabs are used for holding element in place during cut.

Enable:

Enables tabs.

Distance:

Distance between two tabs.

Size:

Size of tabs.

Example of toolpath with tabs enabled:

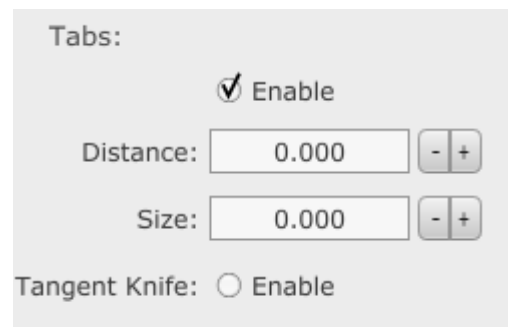

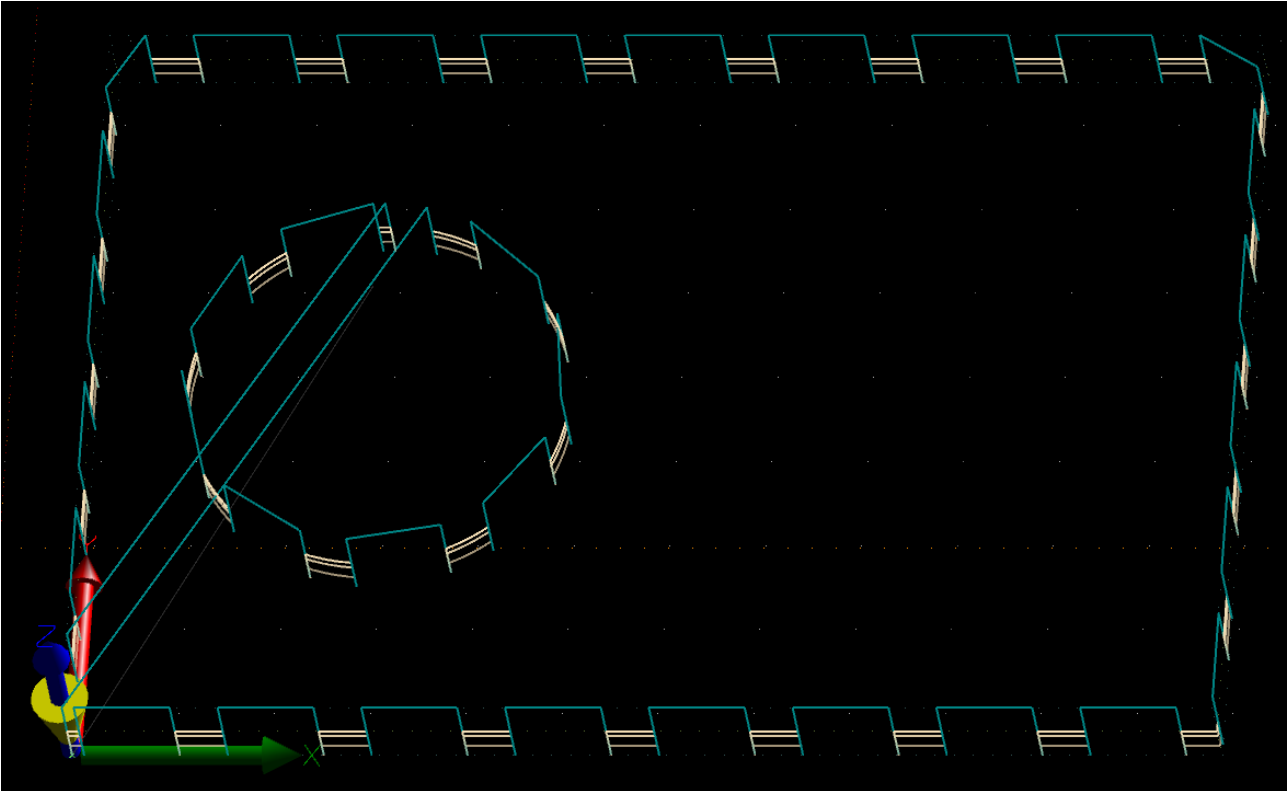

2.4.6.15 *Tangent Knife*

Enable:

Enables C axis movement in direction of toolpath for use with tangential knives. Safe Height moves are generated if required.

2.4.6.16 *Bottom - Off*

Inserts OFF g-codes for Spindle, Flood, Mist (M5,M9), Delay and Pause at the end of cut before moving up to Safe Height

Bottom - Off:

Spindle Flood Mist
 Delay: Pause

Spindle:

Inserts OFF g-code for Spindle M5.

Flood:

Inserts OFF g-code for Flood M9.

Mist:

Inserts OFF g-code for Mist M9.

Delay:

```

17: G01 Z-5.0 F100.0
18: G01 X120.0 F1500.0
19: G01 Y80.0
20: G01 X0.0
21: G01 Y0.0
22: M05
23: M09
24: G01 Z0.0
25: G00 Z10.0
  
```

Inserts Delay G04 P g-code.

Pause:

Inserts Pause M00 g-code.

2.4.6.17 *Top Off*

Inserts OFF g-codes for Spindle, Flood, Mist (M5,M9), Delay and Pause at the end of cut after moving up to Safe Height.

Top - Off:

Spindle Flood Mist

Delay: Pause

Spindle:

Inserts OFF g-code for Spindle M5.

Flood:

Inserts OFF g-code for Flood M9.

Mist:

Inserts OFF g-code for Mist M9.

Delay:

Inserts Delay G04 P g-code

Pause:

Inserts Pause M00 g-code

```
17: G01 Z-5.0 F100.0
18: G01 X120.0 F1500.0
19: G01 Y80.0
20: G01 X0.0
21: G01 Y0.0
22: G01 Z0.0
23: G00 Z10.0
24: M05
25: M09
```

2.4.6.18 Top On

Inserts ON g-codes for Spindle, Flood, Mist (M3,M7,M8), Delay and Pause before cut, before moving down from Safe Height to cut (or pass) height.

Top - On:

Spindle Flood Mist
 Delay: Pause

Spindle:

Inserts ON g-code for Spindle M3.

Flood:

Inserts ON g-code for Flood M7.

Mist:

Inserts ON g-code for Mist M8.

Delay:

Inserts Delay G04 P g-code

Pause:

Inserts Pause M00 g-code

```

5: G00 Z10.0
6: ; Layer: 0
7: ; Feed Speed: 1500.0000
8: ; Plunge Speed: 100.0000
9: ; Safe Height: 10.0000
10: ; Start Height: 0.0000
11: ; Cut Height: -5.0000
12: G00 X0.0 Y0.0
13: M03 S24000.0
14: M07
15: M08
16: G00 Z0.0
17: G01 Z-5.0 F100.0
  
```

2.4.6.19 Bottom On

Inserts ON g-codes for Spindle, Flood, Mist (M3,M7,M8), Delay and Pause before cut, after moving down from Safe Height to cut (or pass) height.

Bottom - On:

Spindle Flood Mist
 Delay: Pause

Spindle:

Inserts ON g-code for Spindle M3.

Flood:

Inserts ON g-code for Flood M7.

Mist:

Inserts ON g-code for Mist M8.

Delay:

Inserts Delay G04 P g-code

Pause:

Inserts Pause M00 g-code

```

5: G00 Z10.0
6: ; Layer: 0
7: ; Feed Speed: 1500.0000
8: ; Plunge Speed: 100.0000
9: ; Safe Height: 10.0000
10: ; Start Height: 0.0000
11: ; Cut Height: -5.0000
12: G00 X0.0 Y0.0
13: G00 Z0.0
14: G01 Z-5.0 F100.0
15: M03 S24000.0
16: M07
17: M08
  
```

2.4.7 Import Gerber

PlanetCNC TNG software will automatically generate toolpath g-code program based on your imported Gerber file.

Gerber files are generated with software for design of printed circuit boards(PCB's). With Gerber files you can also mill printed circuit boards with your CNC machine.

When using **Import Gerber** feature, user dialog will be displayed. User has option to configure program parameters to suit his machining needs.

Gerber

Feed Speed: 1500.0 [- +]
 Plunge Speed: 100.0 [- +]
 Safe Height: 5.000 [- +]
 Start Height: 0.000 [- +]
 Tool Change: Offset:
 Mirror:
 Size X: 0.00 [- +]
 Size Y: 0.00 [- +]
 Outputs: Spindle 24000.0 [- +]
 Flood
 Mist
 Use: Polygons
 Tracks
 Pads Holes

Mark Pads:
 Circle Rectangle
 Oval Polygon
 Other
 Cut Height: -0.150 [- +]
 Pause:
 Tool: 1 [- +]

Drill Pads:
 Circle Rectangle
 Oval Polygon
 Other
 Cut Height: -3.000 [- +]
 Pause:
 Tool: 2 [- +]

Cutting Path:
 Isolation Centerline Outline
 Passes: 1 [- +]
 Cut Height: -0.150 [- +]
 Pause:
 Tool: 3 [- +]
 Diameter: 0.200 [- +]

Clear Copper:
 Enable:
 Outline:
 Border: 0.00 [- +]
 Cut Height: -0.150 [- +]
 Pause:
 Tool: 4 [- +]
 Diameter: 0.200 [- +]

OK Cancel

2.4.7.1 Feed Speed

Sets feed speed for generated toolpath. F-word g-code will be generated. Each G01 move will be performed at this speed.

2.4.7.2 Plunge Speed

Sets feed speed of plunge moves for generated toolpath. Each G01 move in Z- direction will be performed at this speed.

2.4.7.3 Safe Height

Safe height is a safety feature which helps with prevention of machine crashing into obstacles that may interfere with machines toolpath. Obstacles could be screws, fixtures, vises etc..

When machine is finished with cutting toolpath A, it will ascend to safe height and move to next cutting location of toolpath B.

With this option enabled, generated toolpath will include traverse moves performed at safe height.

2.4.7.4 Start Height

Start height is usually surface of workpiece material. To this height, machine will descend at traverse rate.

2.4.7.5 Tool change

Enables tool change for: Mark Pads, Cutting Path, Drill Pads or Clear Copper options.

Generated program will include tool change commands (Tn M6). Tool number used for each milling option is configured with milling option settings of Gerber import dialog.

2.4.7.6 Offset

Tn M6 and G43 Hn g-codes will be generated for enabled milling options.

Offset value will be taken from tool table.

Feed Speed:	<input type="text" value="1500.0"/>	<input type="button" value="-"/>	<input type="button" value="+"/>
Plunge Speed:	<input type="text" value="100.0"/>	<input type="button" value="-"/>	<input type="button" value="+"/>
Safe Height:	<input type="text" value="5.000"/>	<input type="button" value="-"/>	<input type="button" value="+"/>
Start Height:	<input type="text" value="0.000"/>	<input type="button" value="-"/>	<input type="button" value="+"/>
Tool Change:	<input type="radio"/>	Offset:	<input type="radio"/>

2.4.7.7 Mirror

Mirrors program in XY.

Mirror:

Size X: - +

Size Y: - +

Normal toolpath:

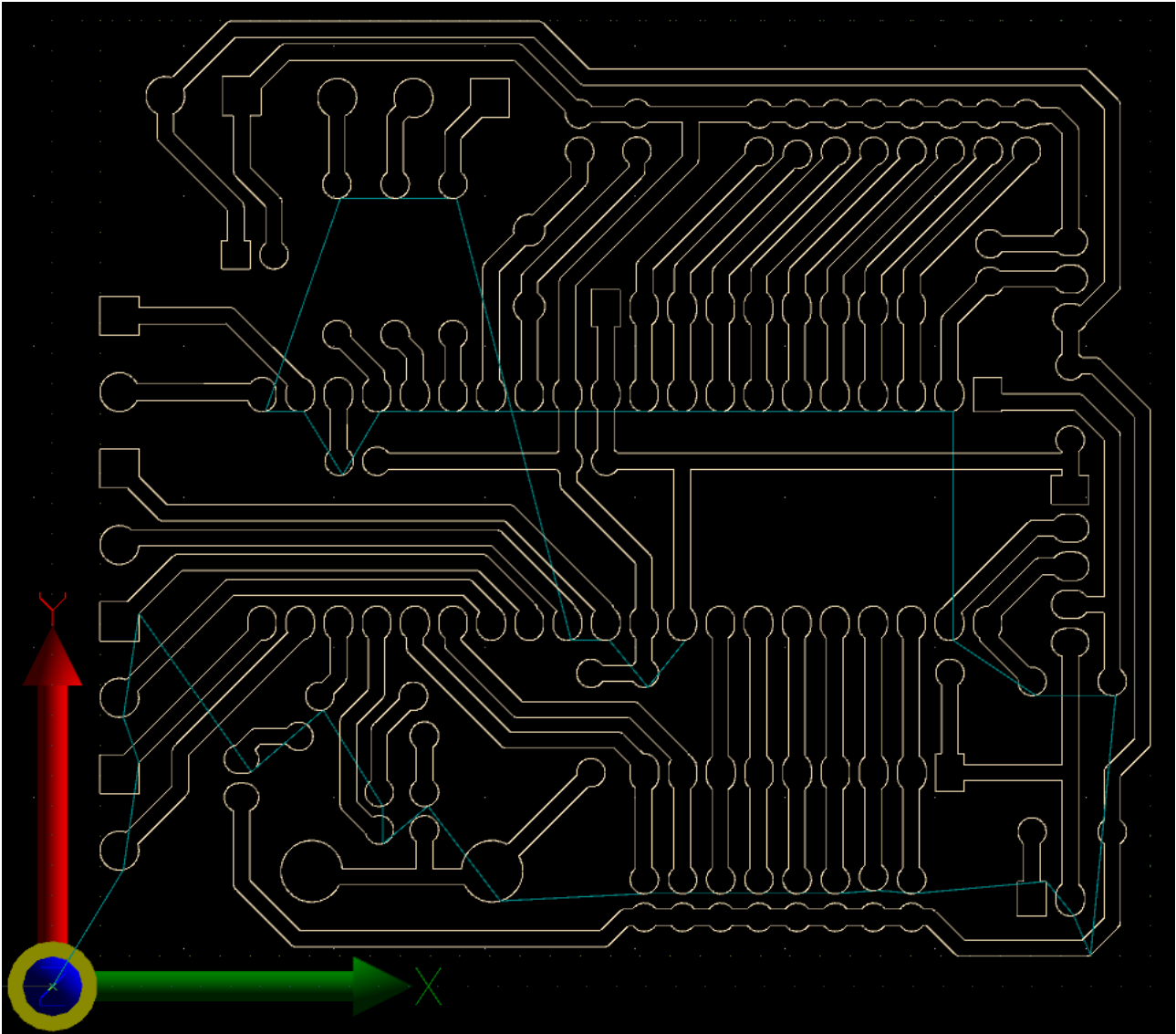

Mirrored toolpath:

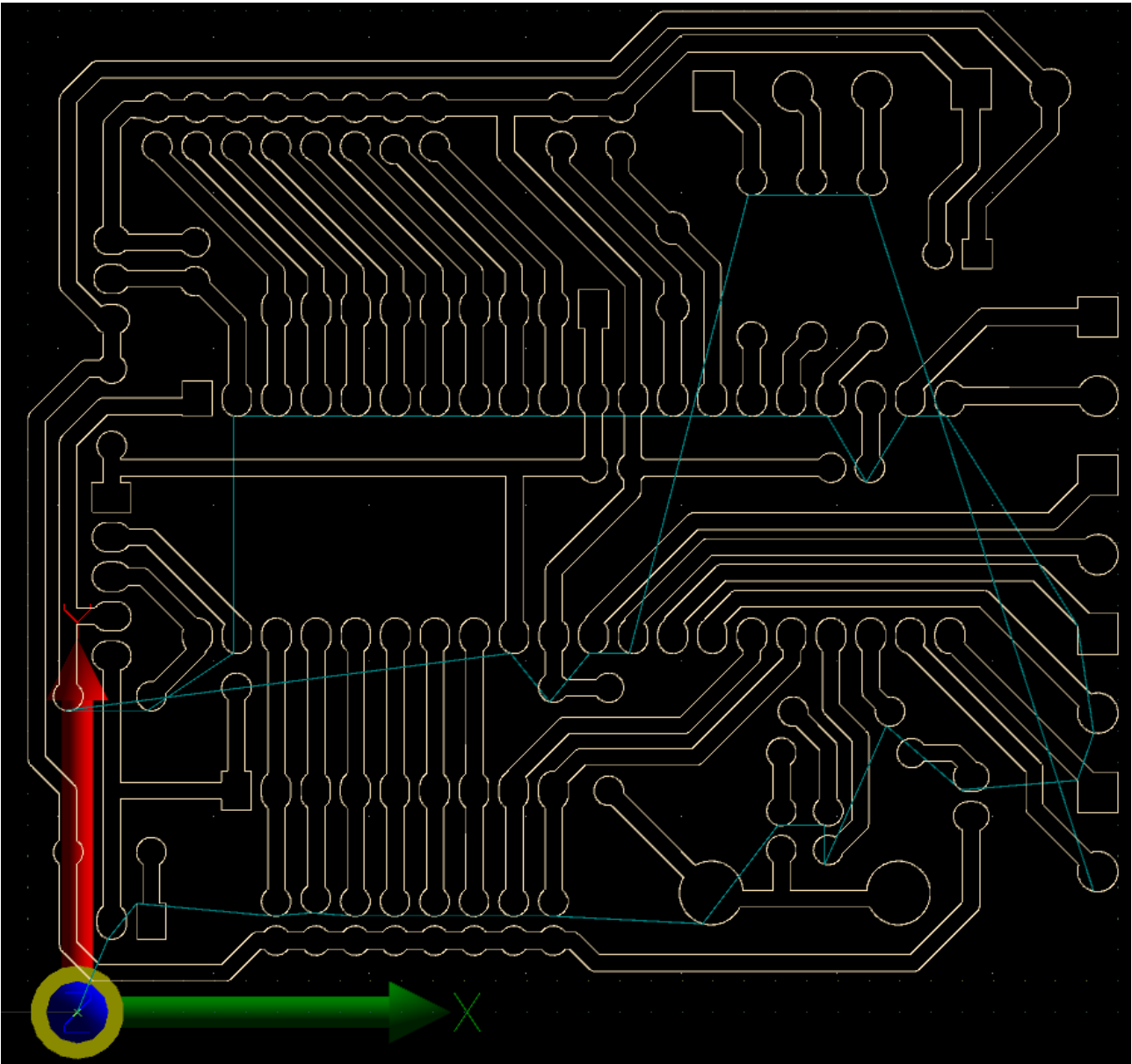

2.4.7.8 Size X

X coordinate approximate dimension of PCB board. This comes very useful when drilling holes of PCB using NC drill file. Make sure that same value is used with NC drill import.

2.4.7.9 Size Y

Y coordinate approximate dimension of PCB board.

2.4.7.10 Outputs

Generated program will include *M3/M5;M7,M8/M9* g-code commands, depending on options selected.



Outputs: Spindle
 Flood
 Mist

24000.0 - +

Spindle:

With this option enabled, generated program will include M3/M5 g-codes. If tool change is enabled M3/M5 g-codes will be generated for each toolchange.

Flood:

With this option enabled, generated program will include M7/M9 g-codes. If tool change is enabled M7/M9 g-codes will be generated for each toolchange.

Mist:

With this option enabled, generated program will include M8/M9 g-codes. If tool change is enabled M8/M9 g-codes will be generated for each toolchange.

2.4.7.11 Use

Gerber files can contain different elements such as polygons, tracks, pads and holes.

You can select which element(s) will be converted to toolpath.

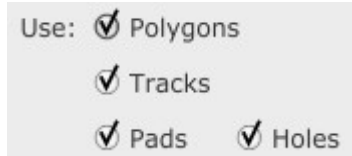
**Polygons:**

Use 'Polygons' in toolpath calculation. Only polygons will be visible.

Tracks:

Use 'Tracks' in toolpath calculation. Only tracks will be visible.

Pads:

Use 'Pads' in toolpath calculation. Only pads will be visible.

Holes:

Use 'holes' in toolpath calculation. Only holes will be visible.

2.4.7.12 Mark Pads

You can mark selected pad shapes to ease manual drilling later. Software will recognize shapes: Circle, Oval, Rectangle, Polygon or Other(custom).



Mark Pads:

Circle Rectangle

Oval Polygon

Other

Cut Height:

Pause:

Tool:

Circle:

Use circle pads for marking. Only circled pads will be marked.

Rectangle:

Use circle pads for marking. Only circled pads will be marked.

Oval:

Use oval pads for marking. Only oval pads will be marked.

Polygon:

Use polygon pads for marking. Only polygon pads will be marked.

Other:

Use other(custom) pads for marking. Only other(custom) pads will be marked.

Cut Height:

Depth of marking point.

Pause

Insert 'Pause' (M00) G-Code before marking pads.

Tool

Number of tool used for marking pads. If tool change is enabled, tool with this number will be used.

2.4.7.13 Cutting Path

Isolation:

Enable to mill electrical isolation toolpath.

Centerline:

Enable to mill center line (for example silkscreen or cutout).

Outline:**Passes:**

Number of milling passes of electrical isolation toolpath. Each milling pass is distanced from previous one for value of tool radius (tool used for Cutting Path).

Cut Height:

Depth of milling.

Pause:

Insert 'Pause' (M00) G-Code before milling electrical isolation toolpath.

Tool:

Number of tool used for milling electrical isolation toolpath. If tool change is enabled, tool with this number will be used.

Diameter:

Diameter of tool used for milling electrical isolation toolpath. Radius of this value is used for *Passes* toolpath.

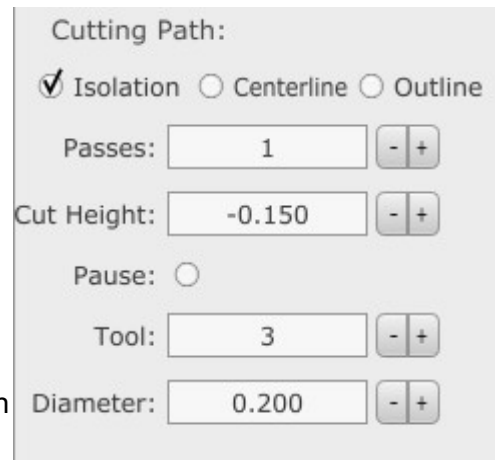

The screenshot shows a 'Cutting Path' settings dialog box. It contains several controls: a checked radio button for 'Isolation', and unchecked radio buttons for 'Centerline' and 'Outline'. Below these are input fields for 'Passes' (value 1), 'Cut Height' (value -0.150), 'Tool' (value 3), and 'Diameter' (value 0.200). Each of these input fields has small '-' and '+' buttons to its right for adjusting the value. There is also an unchecked radio button for 'Pause'.

2.4.7.14 Drill Pads

You can drill selected pad shapes. Software will recognize shapes: Circle, Oval, Rectangle, Polygon or Other(custom).

You might want to drill hole on circled pad for trough hole component but not for rectangle pad for surface mount component.



The screenshot shows a dialog box titled "Drill Pads:". It contains several options and input fields:

- Five radio button options: Circle, Rectangle, Oval, Polygon, and Other.
- A "Cut Height:" label followed by a text input field containing "-3.000" and a numeric spinner control with minus and plus buttons.
- A "Pause:" label followed by an unchecked radio button.
- A "Tool:" label followed by a text input field containing "2" and a numeric spinner control with minus and plus buttons.

Circle:

Use circle pads for drilling. Only circled pads will be drilled.

Rectangle:

Use circle pads for drilling. Only circled pads will be drilled.

Oval:

Use oval pads for drilling. Only oval pads will be drilled.

Polygon:

Use polygon pads for drilling. Only polygon pads will be drilled.

Other:

Use other(custom) pads for drilling. Only other(custom) pads will be drilled.

Cut Height:

Depth of drilling.

Pause:

Insert 'Pause' (M00) G-Code before drilling.

Tool:

Number of tool used for drilling. If tool change is enabled, tool with this number will be used.

2.4.7.15 Clear Copper

Clear Copper:

Enable:

Outline:

Border: - +

Cut Height: - +

Pause:

Tool: - +

Diameter: - +

2.4.7.16 Enable

Generates toolpath that mills ("clears") unused copper. Toolpath without cleared copper:

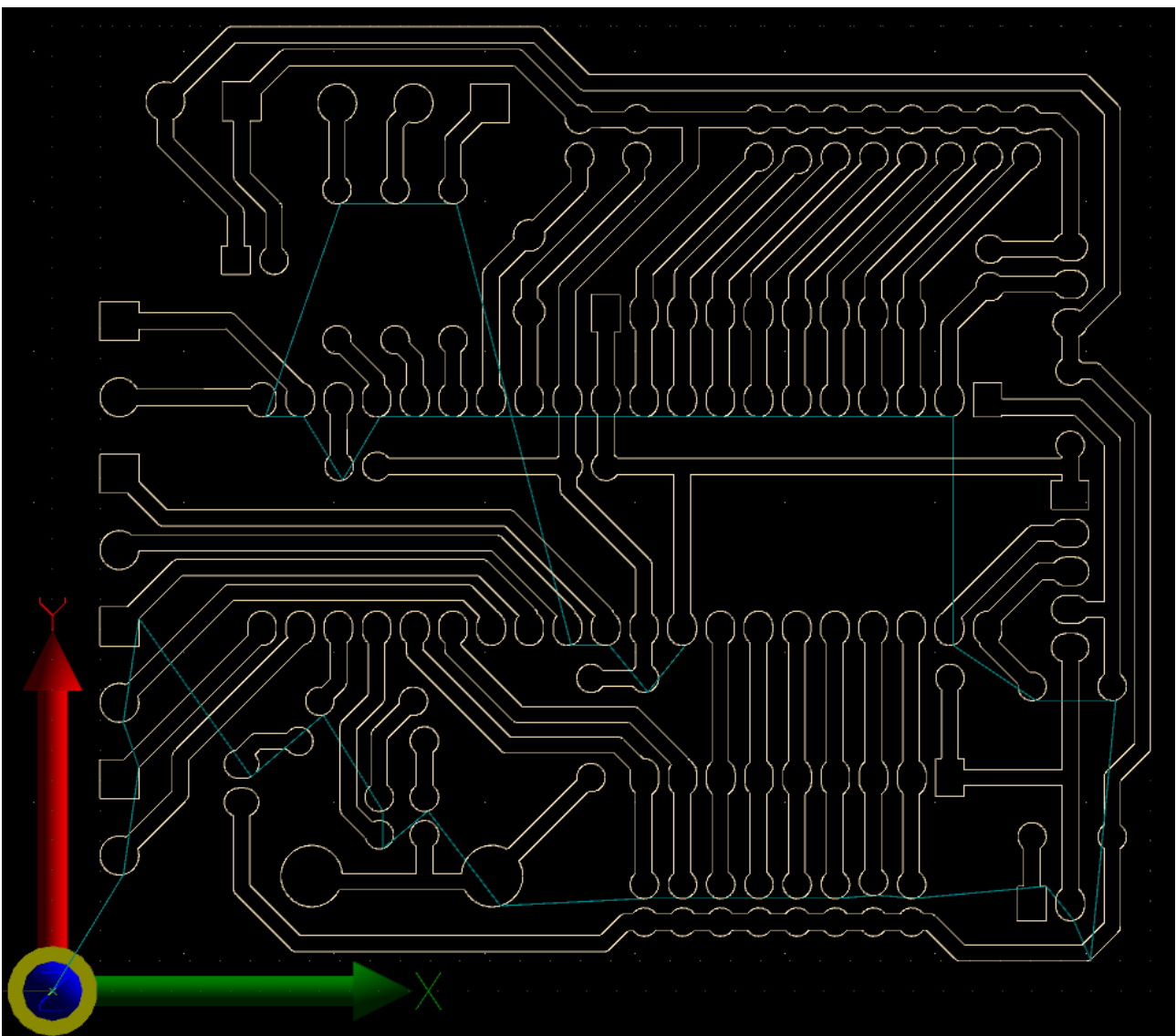

Toolpath with cleared copper:

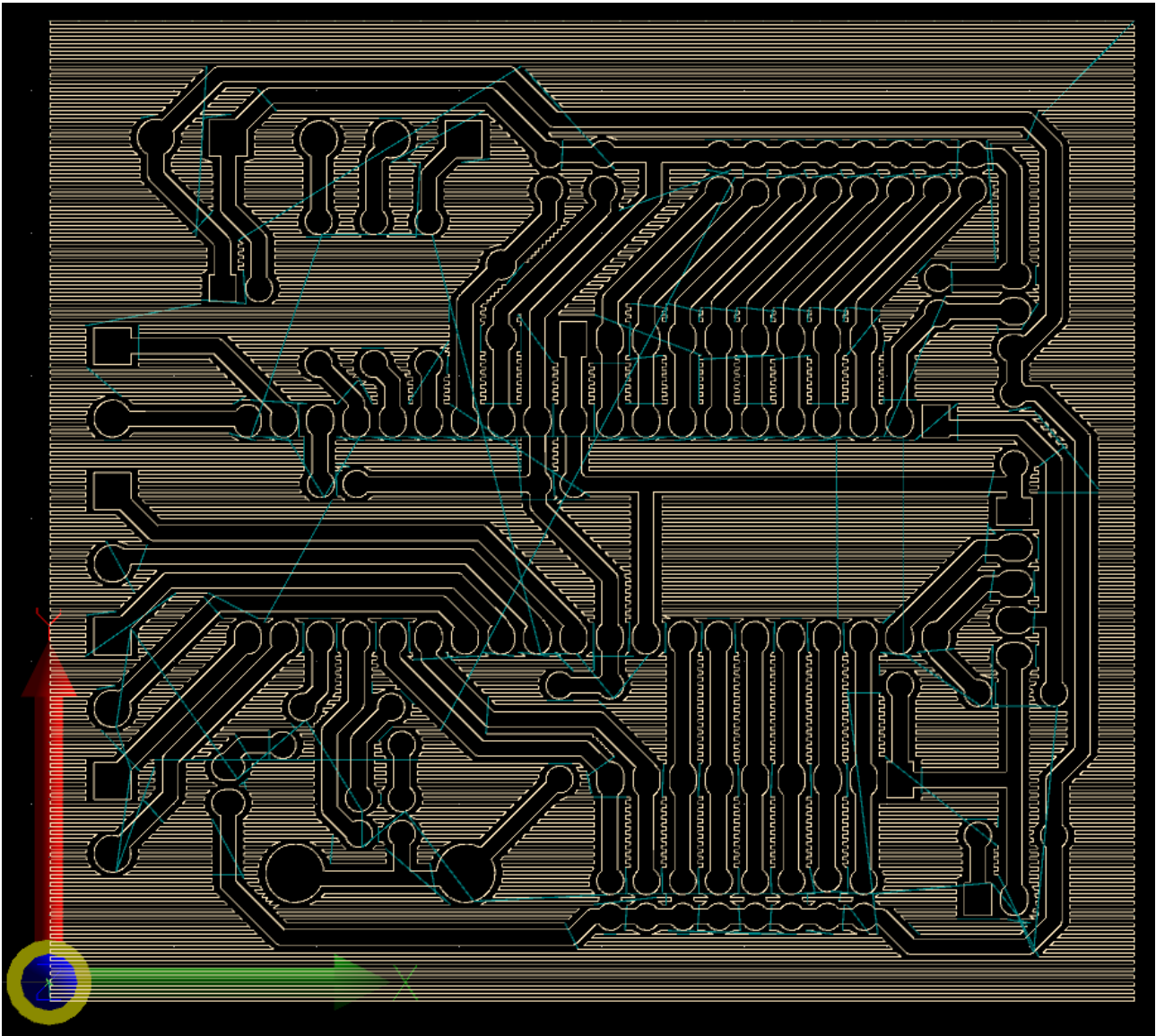

2.4.7.17 Outline

Finishes cleared copper toolpath with additional outline to prevent edges.

Outline:

Without outline:



With outline:



2.4.7.18 Border

Distance value for area beyond PCB max extents where copper will also be milled.

Border: - +

Border zero:

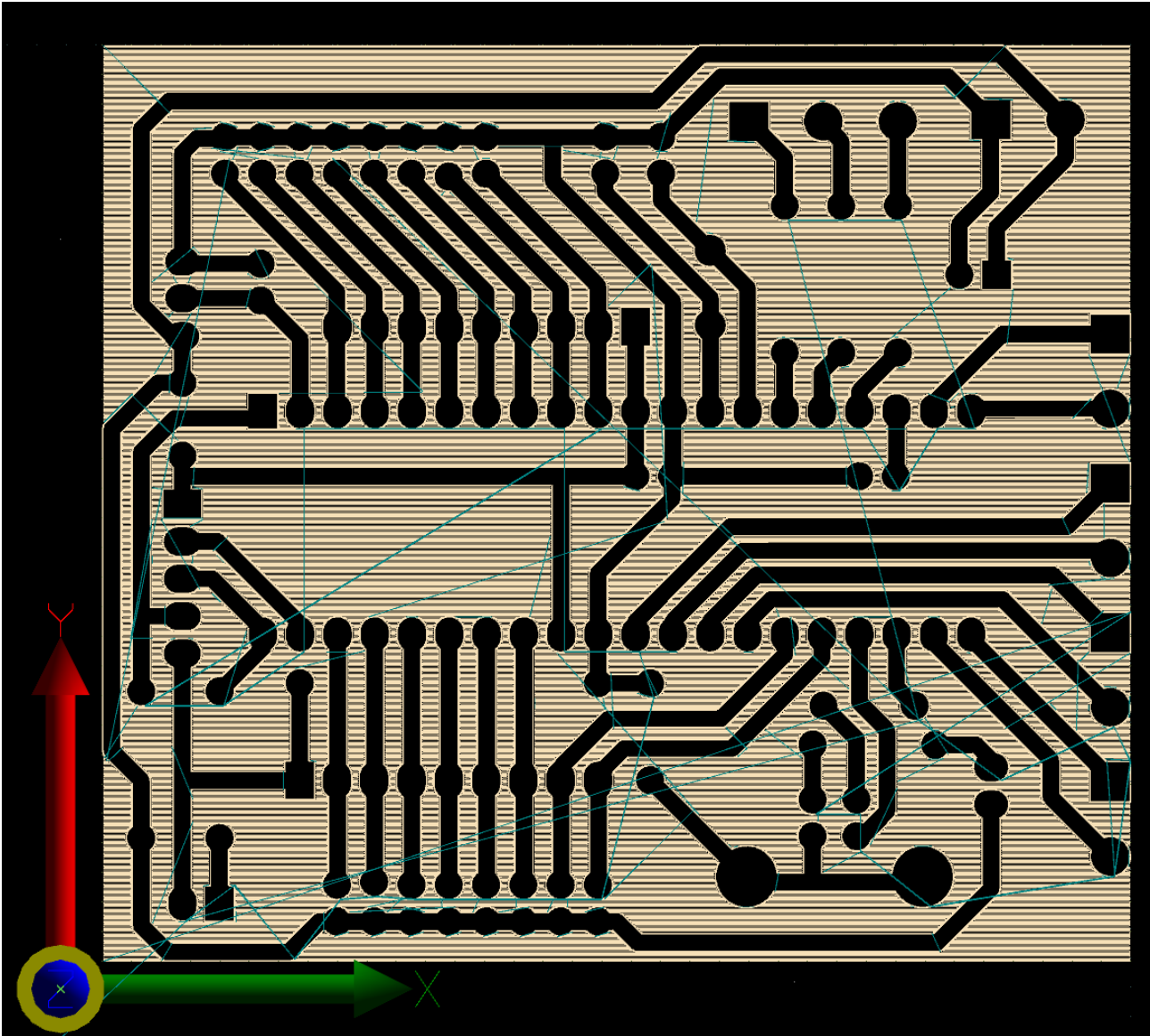

Border value set to 15mm:

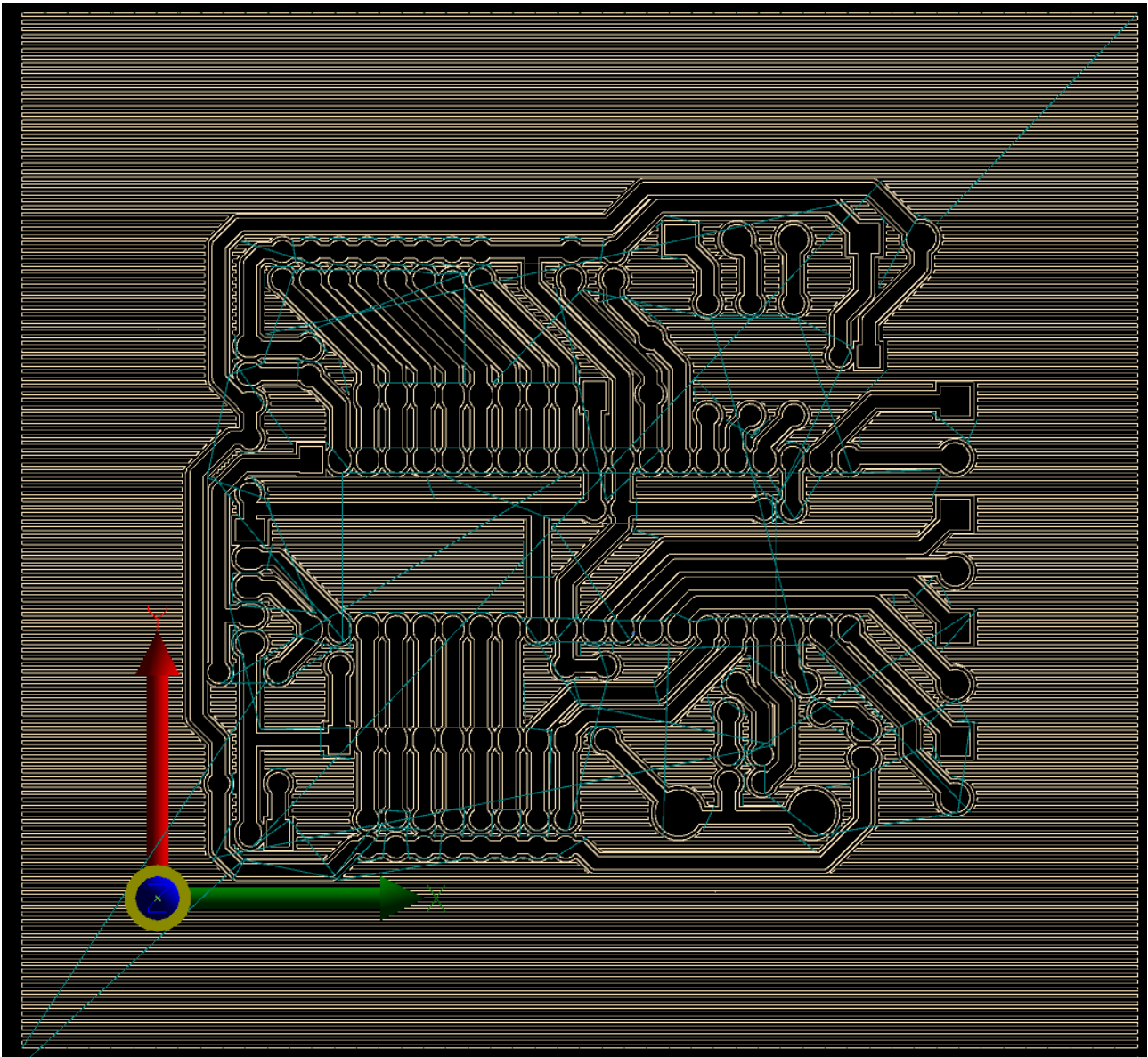

2.4.7.19 *Cute Height*

Depth of clear copper milling.

2.4.7.20 *Pause*

Insert 'Pause' (M00) G-Code before clearing copper.

2.4.7.21 *Tool*

Number of tool used for clearing copper. If tool change is enabled, tool with inserted number will be used.

2.4.7.22 *Diameter*

Diameter of tool used for clearing copper.

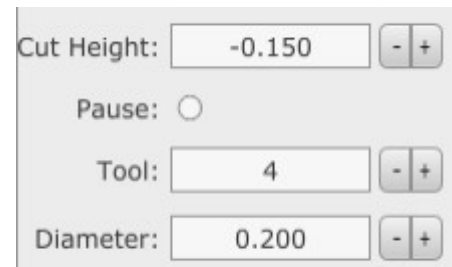

Cut Height: - +

Pause:

Tool: - +

Diameter: - +

2.4.8 Import NC drill

PlanetCNC TNG software will automatically generate toolpath g-code program based on your imported NC drill file.

NC Drill files are generated by software for design of printed circuit boards. NC Drill files are used for drilling holes of printed circuit boards.

When using **Import NC Drill** feature, user dialog will be displayed. User has option to configure program parameters to suit his machining needs.

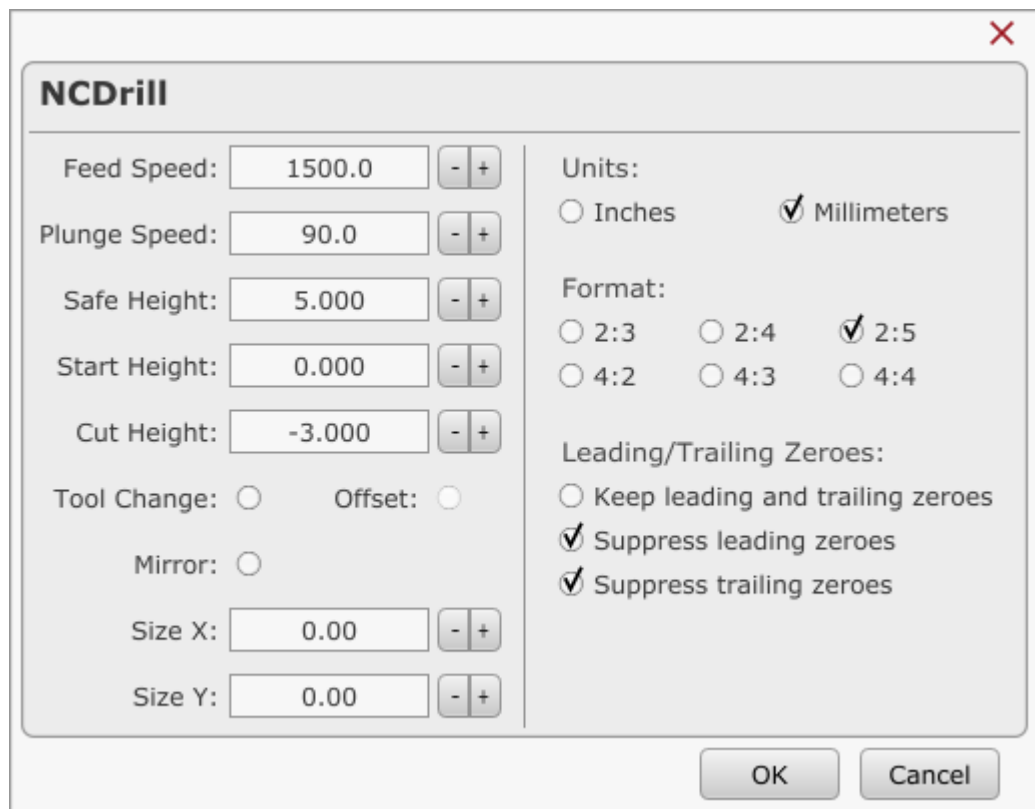

NCDrill

Feed Speed: - +

Plunge Speed: - +

Safe Height: - +

Start Height: - +

Cut Height: - +

Tool Change: Offset:

Mirror:

Size X: - +

Size Y: - +

Units:
 Inches Millimeters

Format:
 2:3 2:4 2:5
 4:2 4:3 4:4

Leading/Trailing Zeroes:
 Keep leading and trailing zeroes
 Suppress leading zeroes
 Suppress trailing zeroes

OK Cancel

2.4.8.1 Feed Speed

Sets feed speed for generated toolpath. F-word g-code will be generated. Each G01 move will be performed at this speed.

Feed Speed:

'Feed Speed' is usually the speed that is used for cutting or milling, and since there will be no cutting involved in the drilling procedure, you can set this value the same as your 'Traverse Speed' in settings.

'Feed speed' is the speed at which machine will descend from 'Safe height' to 'Start height'.

2.4.8.2 Plunge Speed

Sets feed speed of plunge moves for generated toolpath. Each G01 move in Z- direction will be performed at this speed.

Plunge Speed:

2.4.8.3 Safe Height

With this option enabled, generated toolpath will include traverse moves performed at safe height.

Safe Height:

Safe height is a safety feature which helps with prevention of machine crashing into obstacles that may interfere with machines toolpath. Obstacles could be screws, fixtures, vises etc..

When machine is finished with cutting toolpath A, it will ascend to safe height and move to next cutting location of toolpath B.

2.4.8.4 Start Height

Start height is usually surface of workpiece material. Machine will descend from 'Safe Height' to 'Start Height' at feed rate.

Start Height:

2.4.8.5 Cut Height

Cut height is depth of drilling.

Cut Height:

Holes should be drilled in its entirety, meaning, hole should not be drilled half way. Cut Height value is basically the thickness of your PCB with some added safe distance just to be sure that the holes will be drilled "clean".

2.4.8.6 Tool change

Enables tool change for drilling (Tn M6). Tool number used for drilling should be set in NC drill file.

Tool Change: Offset:

2.4.8.7 Offset

Tn M6 and G43 Hn g-codes will be generated for enabled milling options.

Offset value will be taken from tool table.

2.4.8.8 Mirror

Mirrors program in XY.

Mirror:

2.4.8.9 Size X

X coordinate value is approximate dimension of PCB board. Make sure that same value is used with Gerber import.

Size X:
Size Y:

2.4.8.10 Size Y

Y coordinate is approximate dimension of PCB board. Make sure that same value is used with Gerber import.

2.4.8.11 Units

Specify millimetre or inch units.

Units:
 Inches Millimeters

2.4.8.12 Format

Specify number decimal digit format.

Format:
 2:3 2:4 2:5
 4:2 4:3 4:4

2.4.8.13 Leading/Trailing Zeroes

Specify leading and trailing zeroes.

Leading/Trailing Zeroes:
 Keep leading and trailing zeroes
 Suppress leading zeroes
 Suppress trailing zeroes

2.4.9 Import CSV

Imports .CSV file.

2.4.10 Import Image

Imports image, and generates toolpath based on the import parameter configuration.

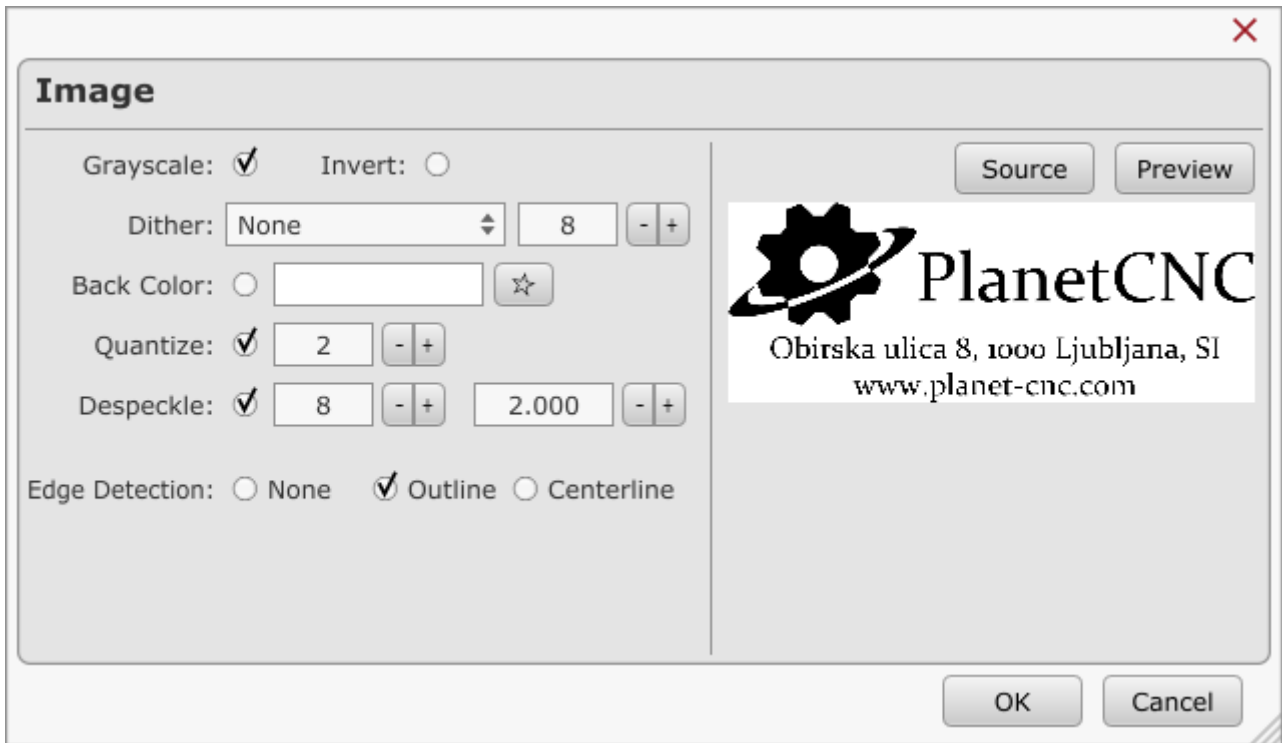

2.4.11 Import Python Script

If Python is installed on your PC and script path is configured, you can import Python script.

2.4.12 Generate

All program files, script files that are located in UserGen folder of Profile folder will be listed here and available for use.

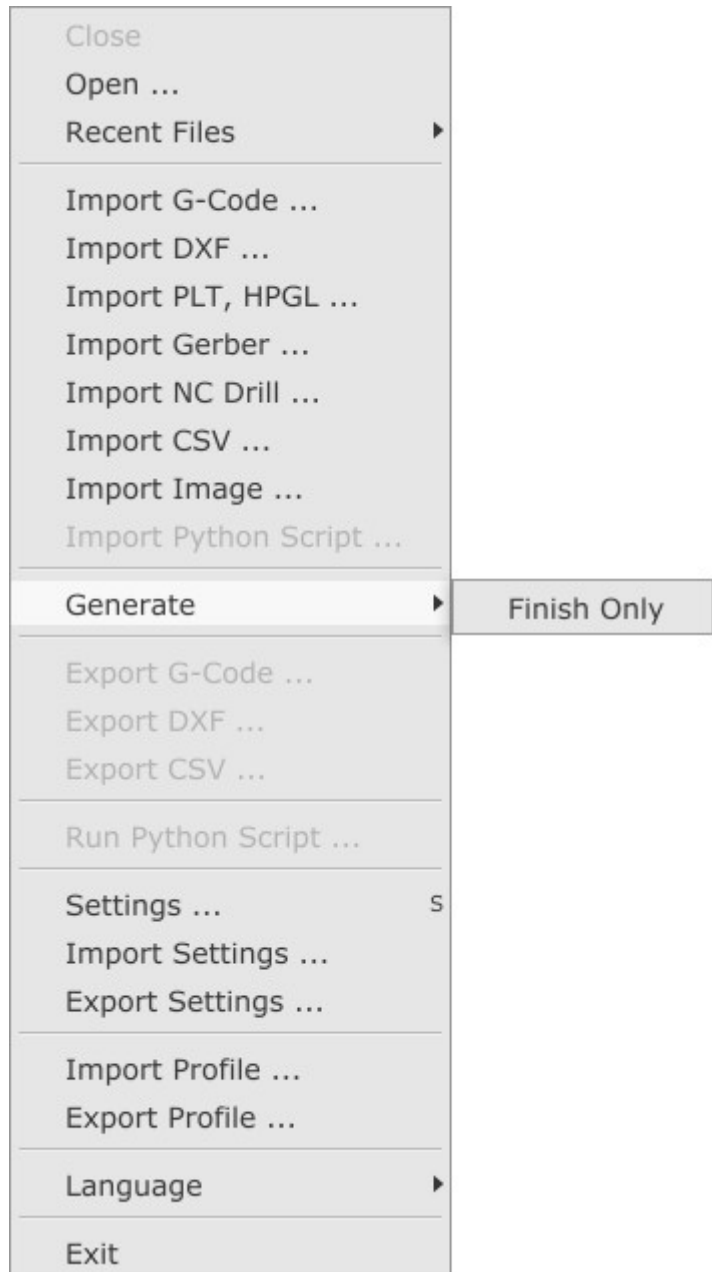

2.4.13 Export G-code

Export current tool-path as G-code file.

2.4.14 Export DXF

Export tool-path as DXF file.

2.4.15 Export CSV

Export tool-path as CSV file.

2.4.16 Run Python Script

Executes Python script.

2.4.17 Settings

In 'Settings' are all main configurations of parameters that are crucial for proper functionality and correct behaviour of machine and attached hardware. See chapter: **2.7 Settings**.

2.4.18 Import Settings

Imports 'Settings' file to quickly restore a known working configuration or to re-configure PlanetCNC TNG software to suit different machines types or applications.

2.4.19 Export Settings

Saves the active 'Settings' file as a backup of the software/machine configuration. Custom options can be stored to quickly configure machines to user requirement.

2.4.20 Import Profile

User can import previously exported/saved Profile of PlanetCNCTNG software.

All profile files and settings configuration will be restored.

2.4.21 Export Profile

Some users can face an obstacle during their time learning and using PlanetCNC TNG software.

While PlanetCNC always tries to give fast and effective support, sometimes more info is needed about the problem user is facing in order to come up with solution as fast as possible.

Backup Profile creates archive file that includes necessary files for PlanetCNC support to start investigating an issue as quickly and effectively as possible.

Backup profile includes:

-*Skins* folder → Includes image files which can be used as skins

-*Icons* folder → Includes image files which can be used for button graphics

-*Data* folder:

Src folder: Last file imported into PlanetCNC TNG software

warp.txt:

trans.txt:

params.txt: File with all parameter values

log_usb.txt: List and specifications of all USB devices connected to PC

log_device.txt: Controllers USB information

gcode.txt: G-code program file that is loaded in TNG when you export backup profile

-*Tool table* file

-*State* files

-*Settings* file

-*Parameters* file

-*Lic.* File (license file)

-*Keys* file

-*Coordinate system* files

-*Toolbar button* files

2.4.22 Language

Select language of application from list of supported languages. You can add language file into the *Lang* folder located in the *Profiles* folder

2.4.23 Exit

Closes PlanetCNC TNG software. If the 'E-Stop' on exit feature is active, machine performs an E-Stop. 'Settings' options allow E-Stop to deactivate spindles and interrupt all motor 'ENABLE' signals, disabling the machine if software is inactive.

2.5 View menu

The view menu controls various aspects of the G-Code program visualization. Only program visualization is affected by view menu options, there are no changes applied to active program G-Code.

Top View	F1
Side View	F2
Front View	F3
Perspective View	F4
<hr/>	
Zoom In	F5
Zoom Out	F6
Zoom Position	F7
Zoom Part	F8
<hr/>	
Follow Position	F9
Center Zero	F10
<hr/>	
Show	▶
<hr/>	
Panel	▶
<hr/>	
Reset Windows	

2.5.1 Top view

Display G-Code / tool-path as viewed from top.

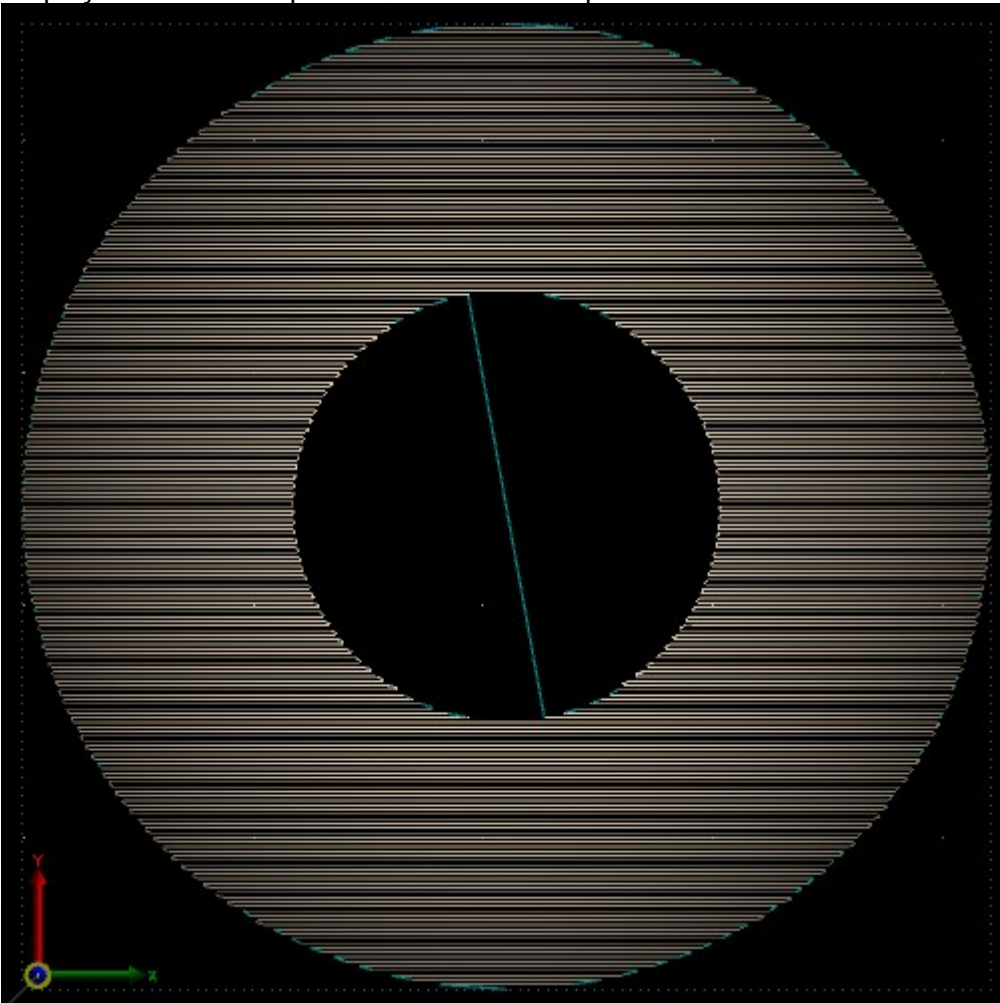

2.5.2 Side View

Display G-Code / tool-path as viewed from side.

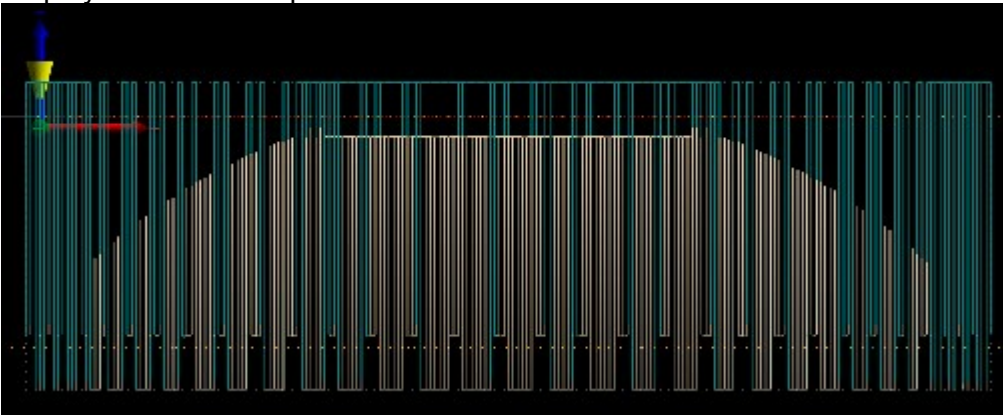

2.5.3 Front View

Display G-Code / tool-path as viewed from front.

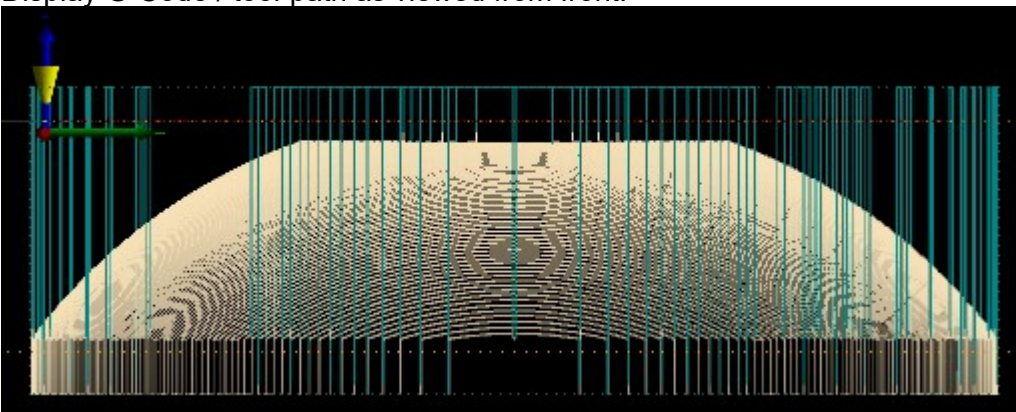

2.5.4 Perspective view

Display G-Code / tool-path using perspective view.

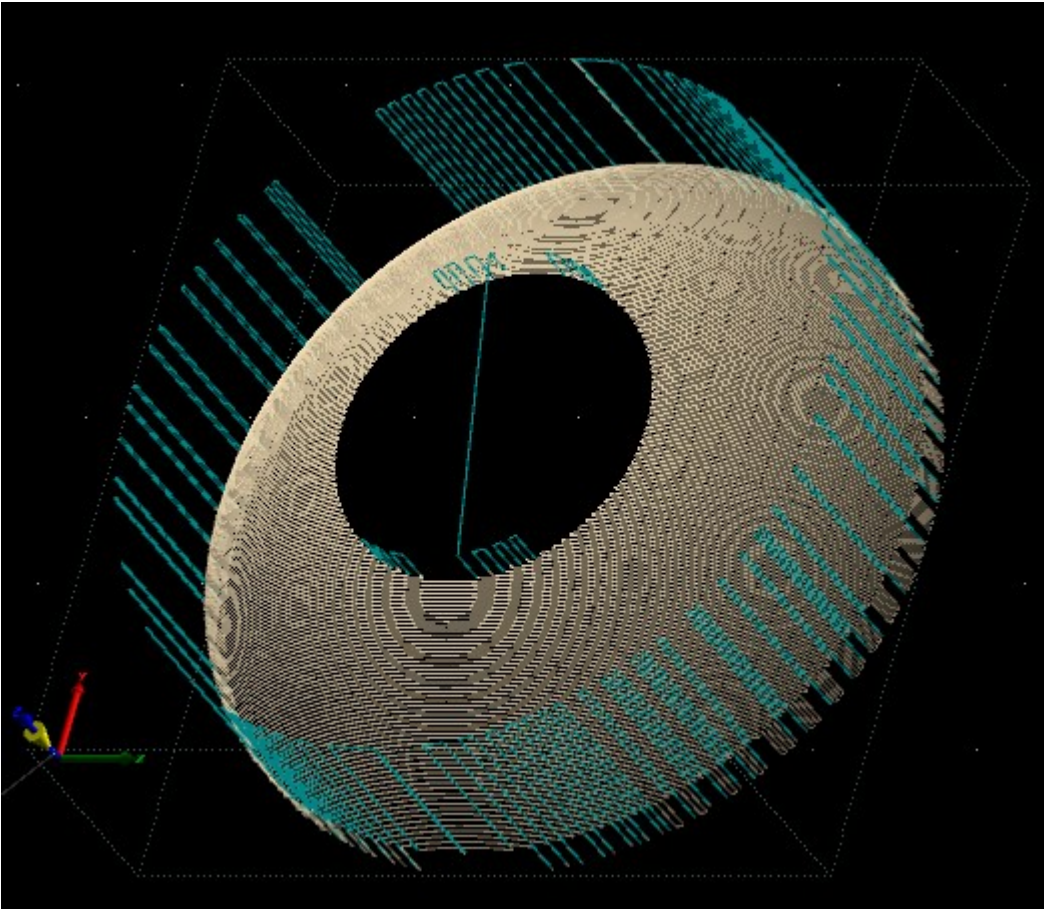

2.5.5 Zoom In

Zooms-in the display for close view of smaller details.

2.5.6 Zoom Out

Zooms-out the display for overview of a larger area.

2.5.7 Zoom Position

Zooms-in for a close view of the current tool position. If G-code line is selected or program is in simulation, simulated tool position will be zoomed instead.

2.5.8 Zoom Part

Zooms-in for a closer view of displayed toolpath.

2.5.9 Follow Position

3D display follows tool over toolpath.

2.5.10 Center Zero

Sets absolute zero position of machine to center of 3D display.

2.5.11 Show

'Show' item opens a sub-menu of elements that can be displayed as part of G-Code visualizations. There are many helpful aids to provide useful feedback. Checked items are visible in visualizations, unchecked items are not.

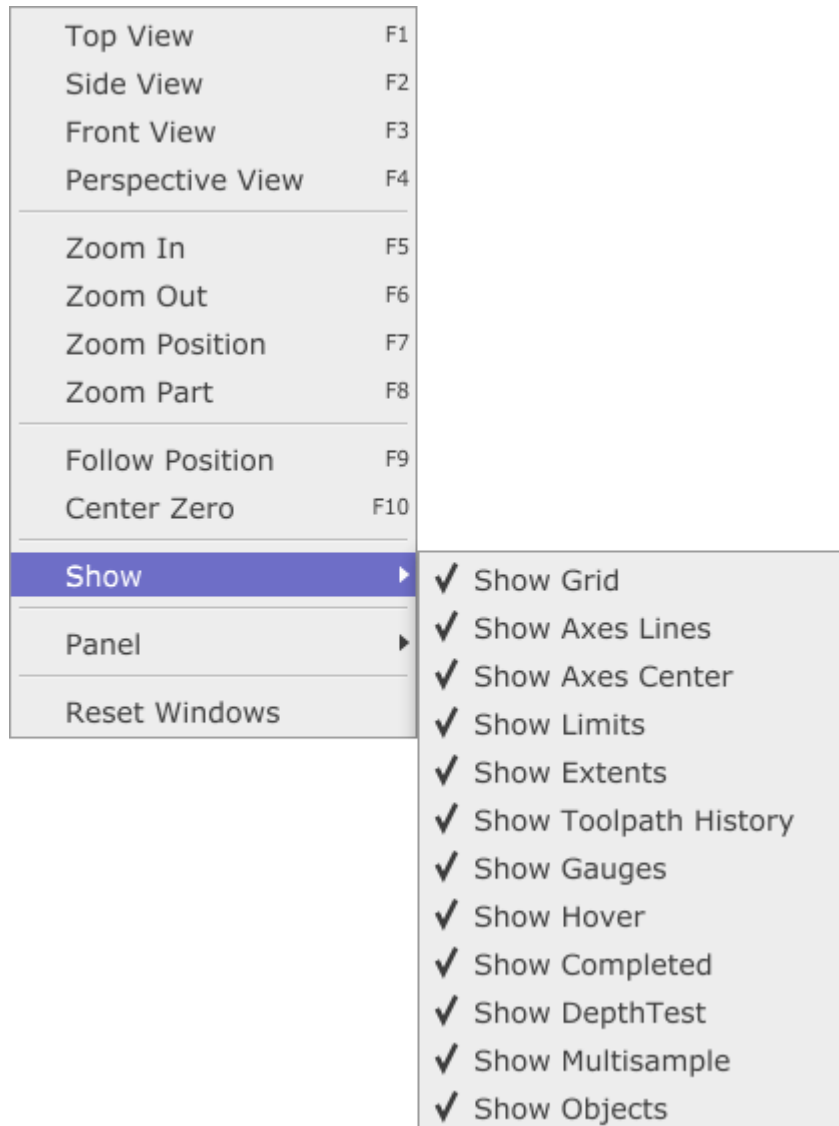

2.5.11.1 Show grid

Displays grid on screen.

2.5.11.2 Show Axes Lines

Displays coordinate system axes.

2.5.11.3 Show Axes Center

Displays centre of axes.

2.5.11.4 Show Limits

Displays motion range limits of machine.

2.5.11.5 Show Extents

Display of toolpath extents. Toolpath is outlined from minimum to maximum edges for all axes.

2.5.11.6 Show Toolpath History

Display of toolpath history. Tool leaves a footprint displayed as line for every move it makes.

2.5.11.7 Show Gauges

Display of gauges for selected axis. Gauge is displayed in left side of 3D display. Gauge helps with the sense of orientation within of axis minimum and maximum limit values.

2.5.11.8 Show Hover

This enables toolpath highlighting when mouse hovers over. Right mouse double click on highlighted line selects corresponding g-code line.

2.5.11.9 Show Completed

Displays completed toolpath. Color of completed toolpath by default is green.

2.5.11.10 *Show Depthtest*

When enabled, toolpath follows depth rules in 3D visualization. When disabled toolpath is drawn over all other objects.

Disabled:

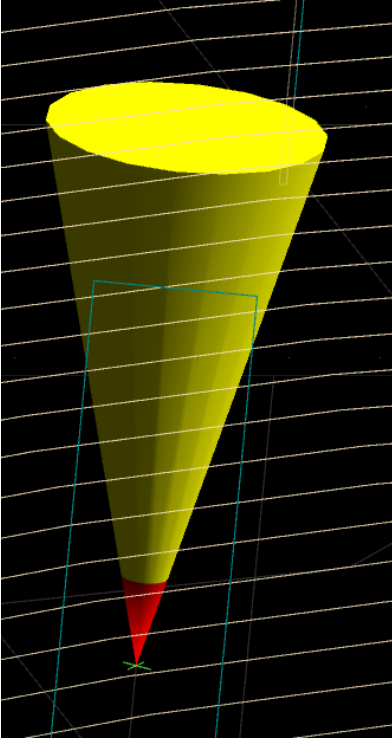

Enabled:

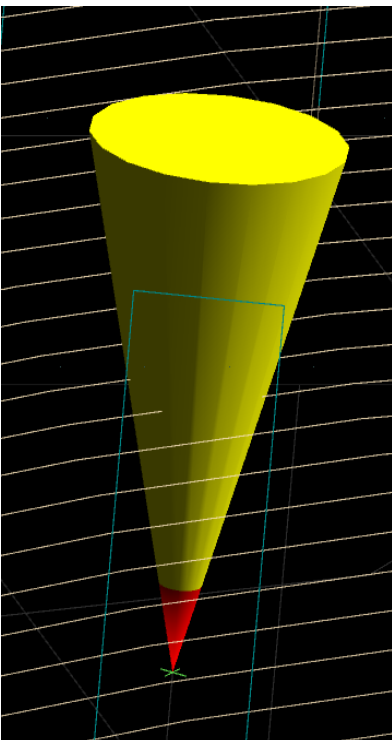

2.5.11.11 Show Multisample

Enables high quality 3D display.

2.5.11.12 Show Objects

Enables display of 3D objects.

2.5.12 Panel

Panel menu items will show/hide panels of PlanetCNC TNG main window interface. Checked menu item indicates that panel is shown, unchecked menu item indicates that panel is hidden.

-Left (Position, Speed, State and Jog panels)

-3D (3D display)

-Right (G-code panel)

-Utilities panels.

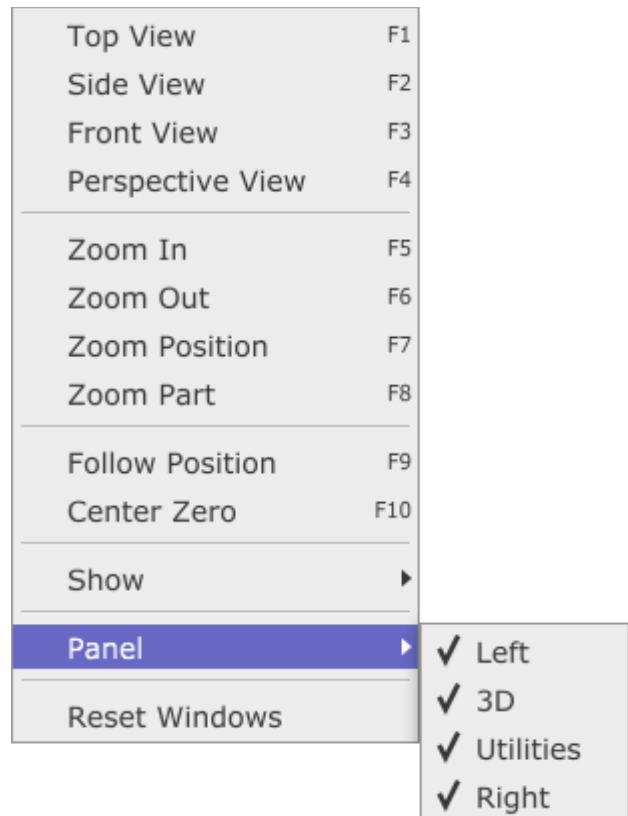

2.5.13 Reset Windows

Resets the main window to preconfigured resolution.

2.6 Program menu

The program menu provides G-Code processing functions to conform NC programs to user requirements. In most cases only parameter entry is required to make desired adjustments.

Functions to navigate NC programs and 'bookmark' blocks of code are also available. NC programs can be 'sectioned' by use of toolchange or pause codes.

Shift, Scale and Rotate can be applied to entire programs. These functions can assist with repeat usage of the same NC program or defined program block, for corners, patterns and so forth.

Redraw	
Edit ...	
Lines	▶
MDI	▶
Bookmarks	▶
Transformation ...	
Shift ...	
Scale ...	
Rotate ...	
Mirror ...	
Points ...	
Clear	
Undo	
Warp ...	
Copy XYZ->UVW	
Copy UVW->XYZ	
Swap XYZ<->UVW	
Copy To Clipboard	Ctrl+C
Paste From Clipboard	Ctrl+V

2.6.1 Redraw

Redraws currently imported g-code programs toolpath.

2.6.2 Edit

Opens currently imported g-code program in a separate window. User can now edit and verify current g-code. With *Update* button user loads edited g-code program into g-code window.

This window can also be embedded into the utilities panel. You would need to enable this in settings.

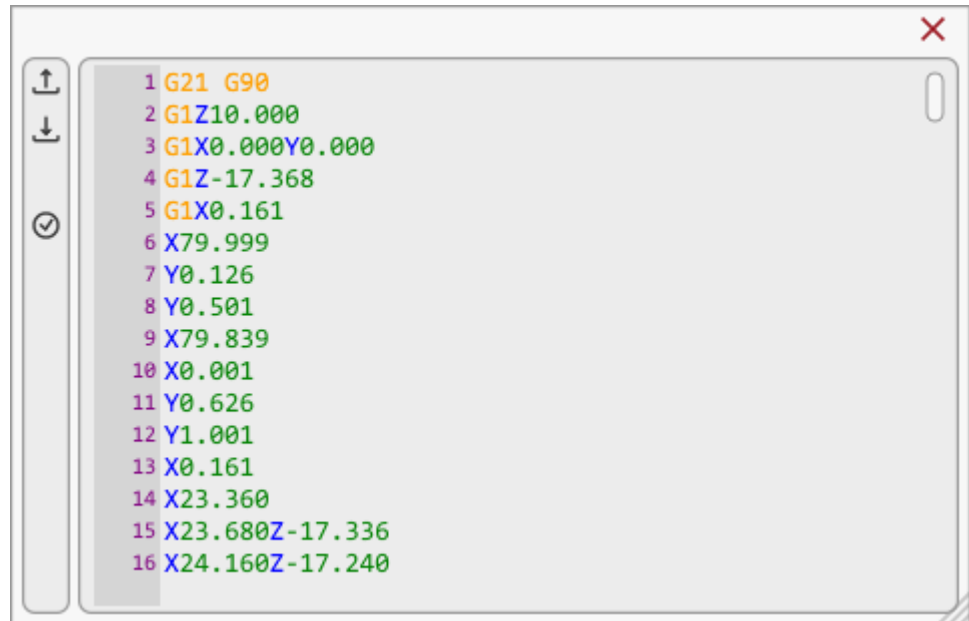

```
1 G21 G90
2 G1Z10.000
3 G1X0.000Y0.000
4 G1Z-17.368
5 G1X0.161
6 X79.999
7 Y0.126
8 Y0.501
9 X79.839
10 X0.001
11 Y0.626
12 Y1.001
13 X0.161
14 X23.360
15 X23.680Z-17.336
16 X24.160Z-17.240
```

Upload button:

Uploads edited program to g-code window.



Download button:

Downloads g-code program from g-code window.



Verify button:

Verifies edited g-code program for any errors.



2.6.3 Lines

'Lines' menu features allow easy navigation through current G-Code program.

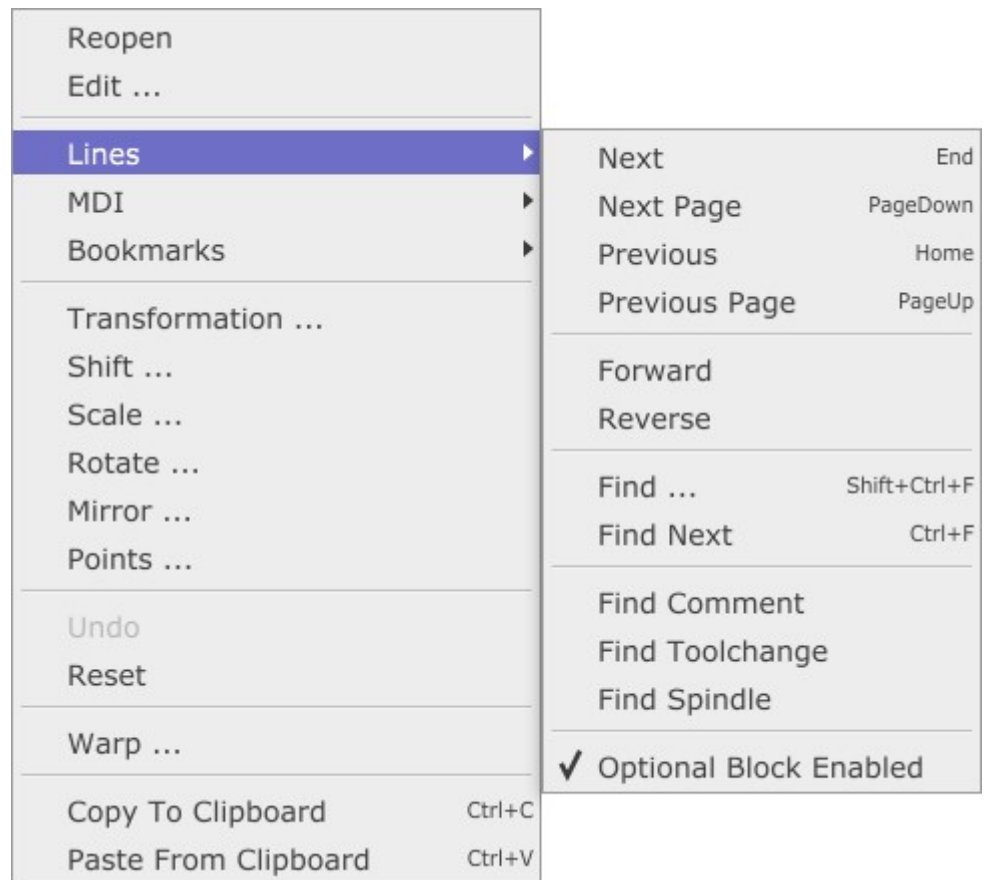

2.6.3.1 Next

Selects next G-code line in G-code window.

2.6.3.2 Next Page

Next page in G-code window is displayed.

2.6.3.3 Previous

Selects previous G-code line in G-code window.

2.6.3.4 Previous Page

Previous page in G-code window is displayed.

2.6.3.5 Forward

Forwards toolpath position slider(see chapter 2.2.5.2).

Recommended use with keyboard shortcut (see chapter 2.7.3.23.2 *Code*) for easier navigation.

2.6.3.6 Reverse

Reverses toolpath position slider(see chapter 2.2.5.2).

Recommended use with keyboard shortcut (see chapter 2.7.3.23.2 *Code*) for easier navigation.

2.6.3.7 Find

You can search for desired keyword through entire g-code program. If keyword is found, corresponding g-code line is selected.



2.6.3.8 Find Next

Selects next line that contains the last keyword used with the *Find* feature.

2.6.3.9 Find Comment

Selects next line that contains comment text.

2.6.3.10 Find Tool-change

Selects G-code line that contains 'M6' G-code.

2.6.3.11 Find Spindle

Selects G-code line that contains 'M3' G-code.

2.6.3.12 Optional Block Enabled

Optional block feature executes or skips lines of program that have character “/” at the beginning of the program line.

This feature comes useful when you need to test proof your program or if you have two versions of the same workpiece with minor changes etc...

In such case you can use “*Optional Block Enabled*” feature which allows you to skip or execute marked lines of g-code of your program. When “*Optional Block Enabled*” is enabled, then marked lines will be skipped.

2.6.4 MDI

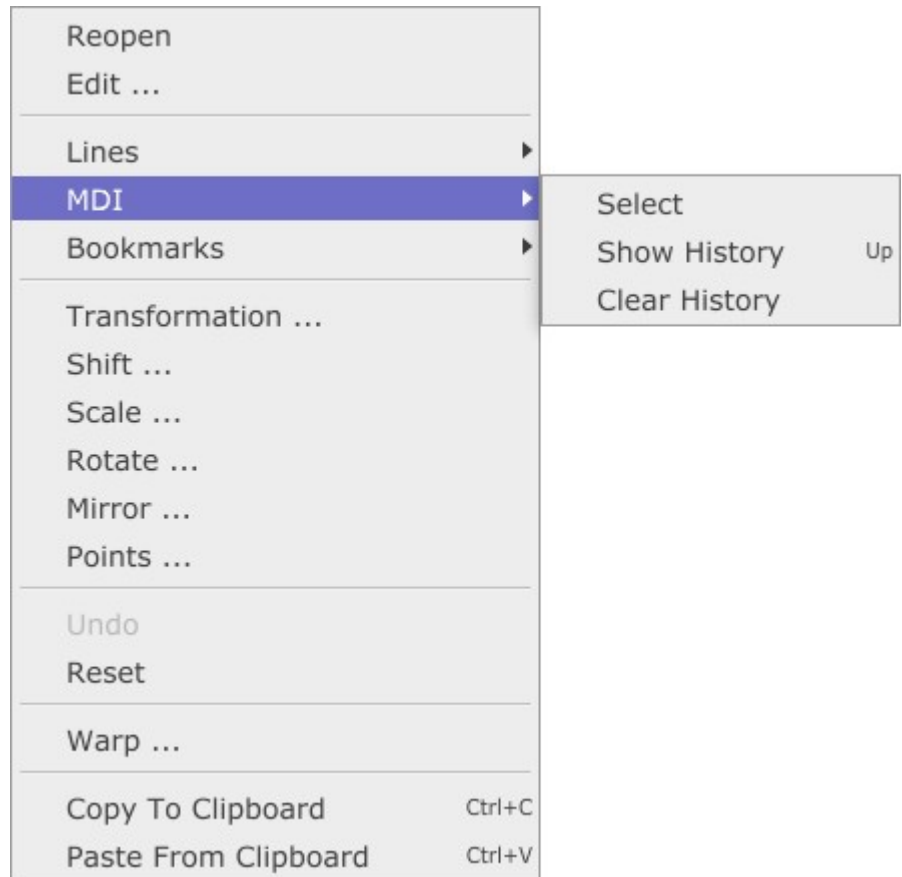

2.6.4.1 Select

Focuses MDI command window.

2.6.4.2 Show history

Displays list of MDI commands previously used.

2.6.4.3 Clear history

Clears list of MDI commands previously used.

2.6.5 Bookmarks

G-code lines can be bookmarked. 'Bookmarks' are set by selection of the G-Code line where the bookmark is required and use of the *Toggle* item or press of the shortcut key. Multiple lines can be bookmarked. When a line has been bookmarked it highlights.

Selection of a 'Bookmark' and press of the *Toggle* item will clear it. Alternatively all 'Bookmarks' can be cleared at once using *Clear*. When bookmarks are cleared highlight are removed.

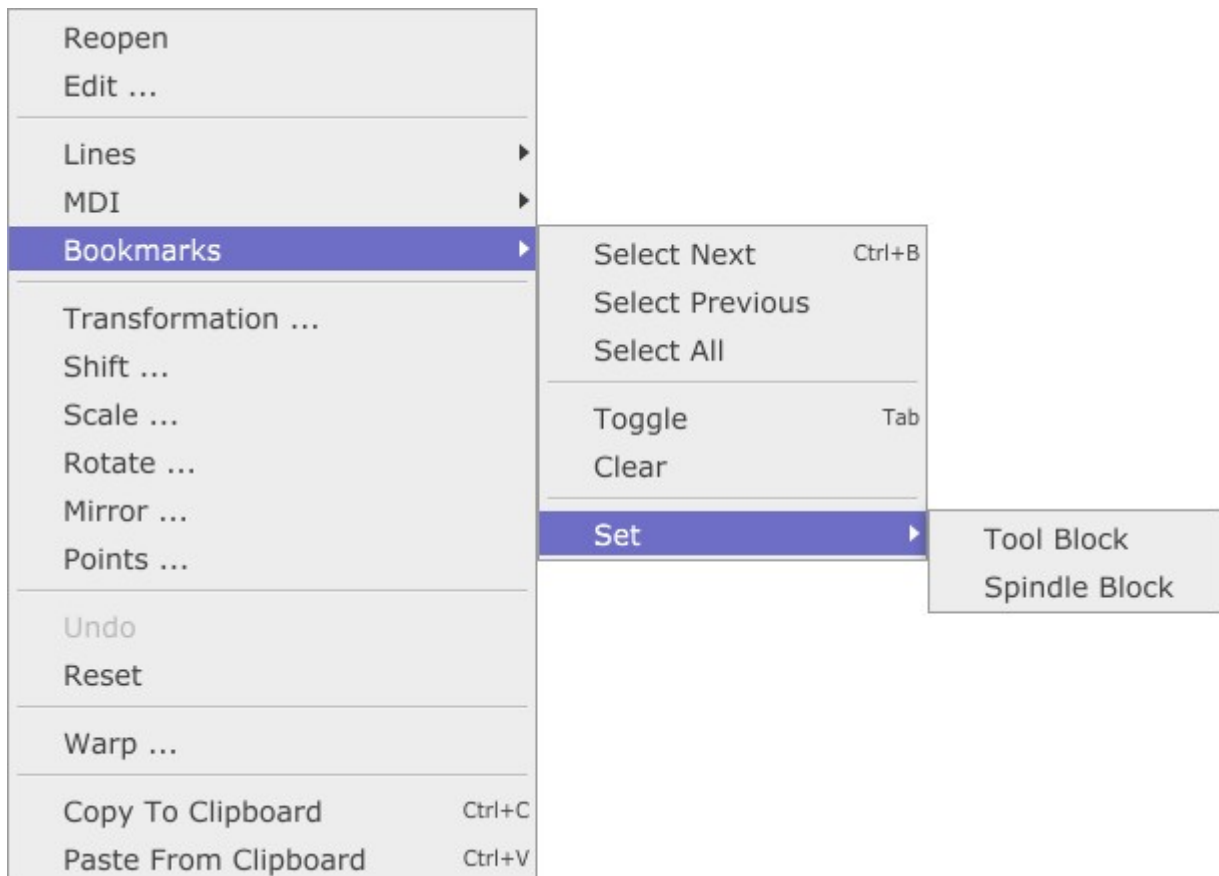

2.6.5.1 Select Next

Selects next bookmarked G-code line.

2.6.5.2 Select previous

Selects previous bookmarked G-code line.

2.6.5.3 Select All

Selects all bookmarked G-code lines.

2.6.5.4 Toggle

Toggles bookmark on selected G-code line.

2.6.5.5 Clear

Clears all bookmarks from G-code lines.

2.6.5.6 Set

Tool Block:

Highlights lines of code that are executed with same tool number.

Spindle Block:

Highlights lines of code that are executed under active M3 code.

2.6.6 Transformation

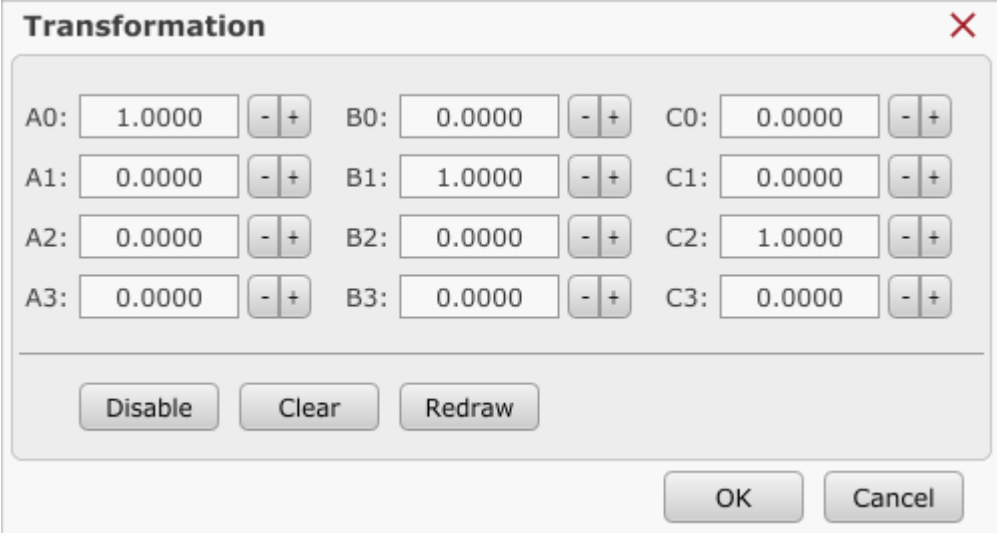

The image shows a software dialog box titled "Transformation" with a red close button in the top right corner. The dialog contains a 4x3 grid of input fields for transformation coefficients. Each field is followed by a small control with minus and plus signs. The values are: A0: 1.0000, B0: 0.0000, C0: 0.0000; A1: 0.0000, B1: 1.0000, C1: 0.0000; A2: 0.0000, B2: 0.0000, C2: 1.0000; A3: 0.0000, B3: 0.0000, C3: 0.0000. Below the grid are three buttons: "Disable", "Clear", and "Redraw". At the bottom right are "OK" and "Cancel" buttons.

A0:	1.0000	- +	B0:	0.0000	- +	C0:	0.0000	- +
A1:	0.0000	- +	B1:	1.0000	- +	C1:	0.0000	- +
A2:	0.0000	- +	B2:	0.0000	- +	C2:	1.0000	- +
A3:	0.0000	- +	B3:	0.0000	- +	C3:	0.0000	- +

Buttons: Disable, Clear, Redraw, OK, Cancel

2.6.6.1 Disable

Disables transformation. Transformation coefficient values will not have any effect on the toolpath.

2.6.6.2 Clear

Clears all current transformation coefficient values to their default values.

2.6.6.3 Redraw

If user manually configures any new transformation coefficient values, this button will redraw current toolpath.

If you right click on an empty field of Transformation dialog, additional options will appear:

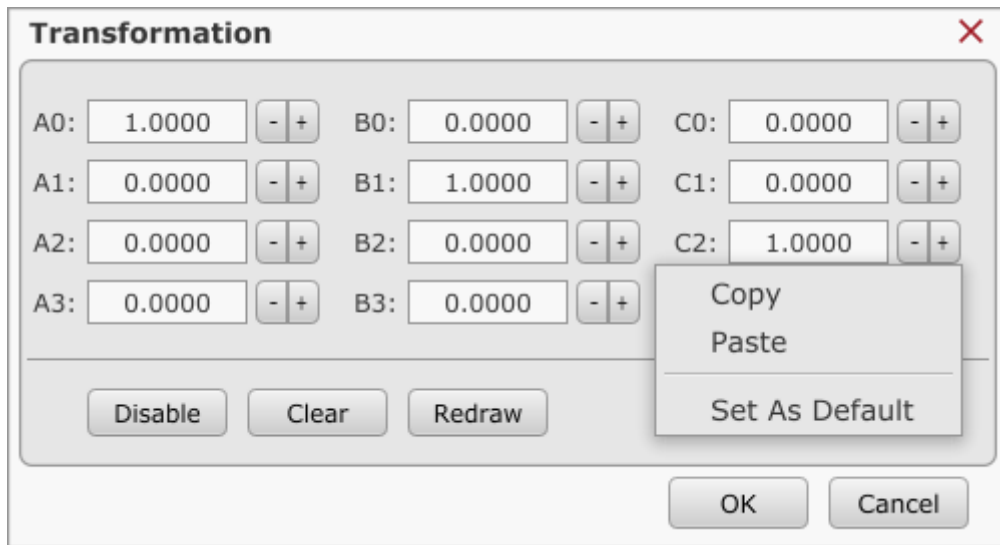
**Copy:**

Copies transformation coefficient values to clipboard in a form of gcode "G10 L3....".

Paste:

Pastes transformation coefficient values from clipboard in a form of gcode "G10 L3....".

Set As Default:

Current transformation configuration will be set as default configuration.

When PlanetCNC TNG sw will be executed, transformation will enabled. This way user can set permanent transformation configuration.

This transformation configuration will also populate transformation coefficient fields in settings:

File/Settings/Program Options/Transformation

2.6.7 Shift

Shift translates or moves the tool-path in 3D space using one of many options.

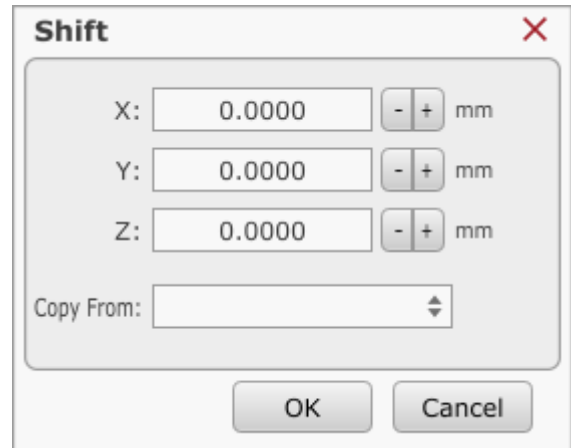

Shift ✕

X: - + mm

Y: - + mm

Z: - + mm

Copy From:

OK Cancel

2.6.7.1 X,Y,Z:

Shifts toolpath in any axis for inserted value.

2.6.7.2 Copy From

User can shift toolpath using available preset shift options.

- Zero
- Extents To Zero
- Extents To Position
- Extents To Camera
- Center To Zero
- Center To Position
- Center To Camera
- G-Code Line To Zero
- G-Code Line To Position
- G-Code Line To Camera

2.6.7.2.1 Zero

Sets shift value for all axes to zero.

2.6.7.2.2 Extents To Zero

Aligns the 'minimum' edges of the tool-path extents with machine zero position.

2.6.7.2.3 Extents To Position

Aligns the 'minimum' edges of the tool-path extents with current machine position.

2.6.7.2.4 Extents To Camera

Aligns the 'minimum' edges of the tool-path extents with camera cross-hair view.

2.6.7.2.5 Center To Zero

Aligns the center of the tool-path with machine zero position.

2.6.7.2.6 Center To Position

Aligns the center of the tool-path with current machine position.

2.6.7.2.7 Center To Camera

Aligns the center of the tool-path with camera cross-hair view.

2.6.7.2.8 G-Code Line To Zero

Aligns the toolpath segment of selected g-code line with machine zero position.

2.6.7.2.9 G-Code Line To Position

Aligns the toolpath segment of selected g-code line with current machine position.

2.6.7.2.10 G-Code Line To Camera

Aligns the toolpath segment of selected g-code line with with the camera cross-hair view.

2.6.8 Scale

Scale adjusts dimensions of the tool-path using 'factor' based scaling. Default value of 1.00 is equivalent to 100% scale or actual size. A scale factor setting of 2.00 increases tool-path dimensions to 200% of the original size in the relevant axis.

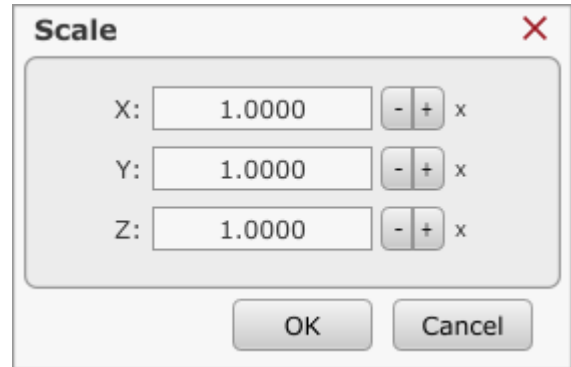

The **Scale** dialog box contains three input fields for X, Y, and Z axes, each with a value of 1.0000. To the right of each field are two buttons: a minus sign and a plus sign, followed by a small 'x' icon. At the bottom of the dialog are two buttons: **OK** and **Cancel**.

2.6.8.1 X,Y,Z:

Scales toolpath of selected axis for inserted value.

2.6.9 Rotate

Rotates the tool-path in XY, YZ or ZX plane with origin as the centre of rotation. Positive values rotate the tool-path in a clockwise direction. Negative values cause counter-clockwise rotation.



The **Rotate** dialog box contains three input fields for XY Plane, YZ Plane, and ZX Plane, each with a value of 0.000. To the right of each field are two buttons: a minus sign and a plus sign, followed by a degree symbol (°). At the bottom of the dialog are two buttons: **Apply** and **Close**.

2.6.10 Mirror

Mirror function mirrors tool-path over X, Y, Z axes. Axis of reflection is selected by enabling radio button.

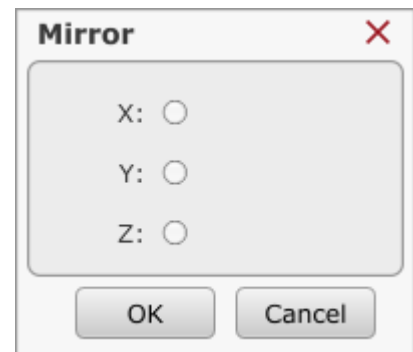

2.6.11 Points

Calculates transformation from first group of points to second group of points.



Points ✕

Source: --- Destination: ---

Add Update Delete Redraw

X	Y	X	Y
---	---	---	---

Load ... Save ... OK Cancel

2.6.11.1 Source

Beside manual input, user can select option from drop down menu as source coordinates of transformation point.

Choose among options: *Zero, G-Code Line, Position, Camera*:

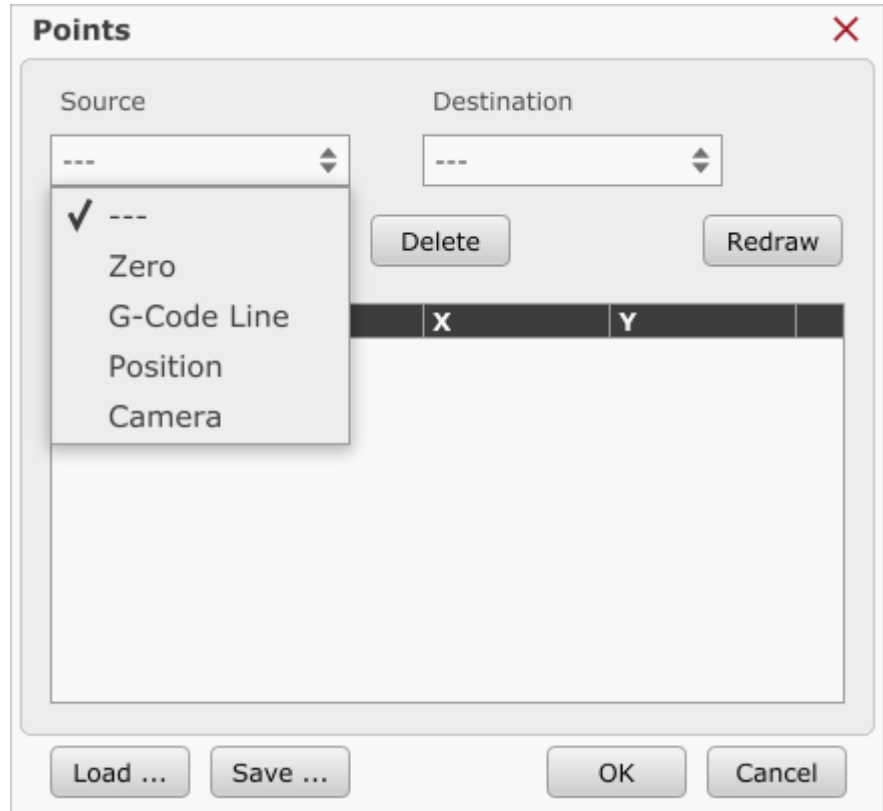
**Zero:**

Sets zero coordinate values for source point.

G-code Line:

Sets coordinate values for source point obtained from selected line in g-code panel.

Position:

Sets coordinate values for source point obtained from machine position.

Camera:

Sets coordinate values for source point obtained from camera position.

2.6.11.2 Destination

Beside manual input, user can select option from drop down menu for destination coordinates of transformation point.

Choose among options: *Zero*, *G-Code Line*, *Position*, *Camera*:

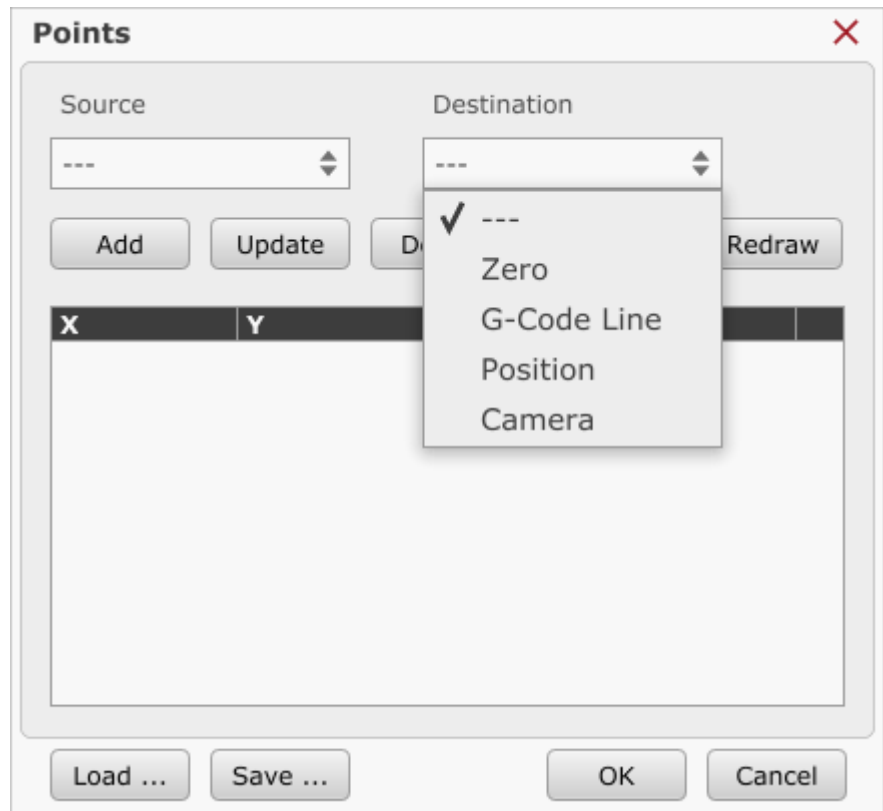
**Zero:**

Sets zero coordinate values for destination point.

G-code Line:

Sets coordinate values for destination point obtained from selected line in g-code panel.

Position:

Sets coordinate values for destination point obtained from machine position.

Camera:

Sets coordinate values for destination point obtained from camera position.

Add:

Adds new point row.

Update:

Updates highlighted point row with new values depending on 'Source' and/or 'Destination' option selected.

Delete:

Deletes point row.

Redraw:

Redraws current gcode programs toolpath.

Load ... :

Loads points configuration.

Save ... :

Saves points configuration.

2.6.12 Clear

Clears all parameters of Program menu features. Any applied changes from program menu will be reset.

2.6.13 Undo

Cancels applied changes from program menu items: *Shift*, *Scale*, *Rotate*, *Mirror*, *Points*, *Copy...*, *Swap...*

2.6.14 Warp

Applies *Warp* feature to current tool-path, based on measured points. If measured points are saved into file, you can load them with *Load points* button.



2.6.14.1 Resolution

Interpolation resolution value of warped toolpath.

2.6.14.2 Enable/Disable

This button toggles between Enabled and Disabled Warp.

When enabled, Warp is applied, when disabled, Warp is not applied.

2.6.14.3 Clear

Clears all imported points whether from *From File* or *From Points*.

2.6.14.4 From File

User can import measured surface points from previously saved file.

If you saved your measured surface points, you use this button.

Points can be saved using *Machine/Points/Save*.

2.6.14.5 From Points

Directly imports group of measured surface points obtained using *Machine/Measure/Surface* feature.

Example: Points were measured using Machine/Measure/Surface.

Open *Warp* dialog window:

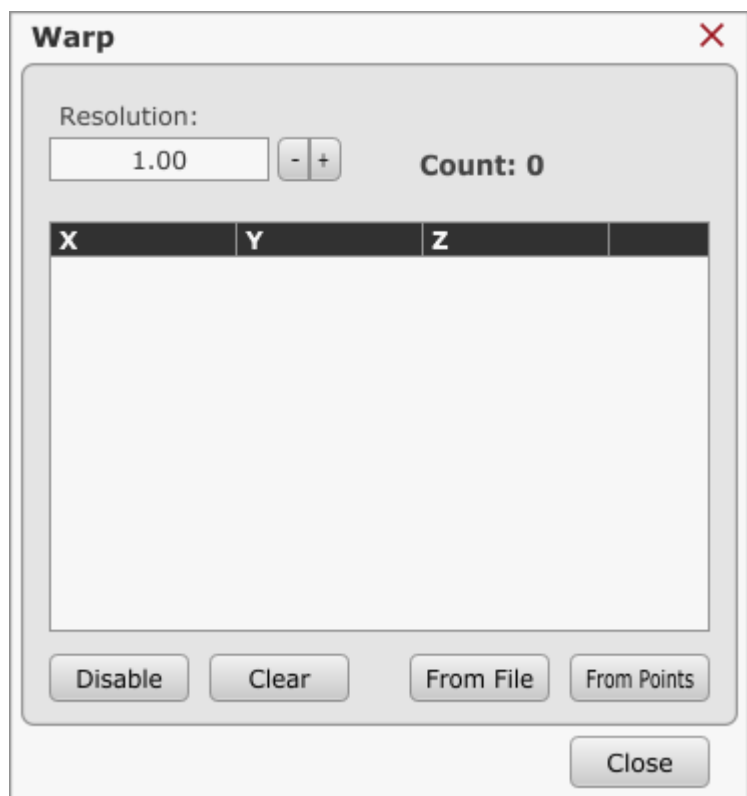

Click *From Points* button:

The 'Warp' dialog box is shown with a resolution of 1.00 and a count of 18. The 'From Points' button is highlighted in a darker shade, indicating it is the active selection.

X	Y	Z
23.3800	3.4000	10.8060
24.3800	3.4000	14.0560
25.3800	3.4000	12.0110
26.3800	3.4000	13.0710
27.3800	3.4000	13.6240
28.3800	3.4000	13.8630
29.3800	3.4000	14.3900
30.3800	3.4000	15.3260
31.3800	3.4000	15.3910
32.3800	3.4000	15.1470
33.3800	3.4000	15.1740

Click *Enable* button:

The 'Warp' dialog box is shown with a resolution of 1.00 and a count of 18. The 'Enable' button is highlighted in a darker shade, indicating it is the active selection.

X	Y	Z
23.3800	3.4000	10.8060
24.3800	3.4000	14.0560
25.3800	3.4000	12.0110
26.3800	3.4000	13.0710
27.3800	3.4000	13.6240
28.3800	3.4000	13.8630
29.3800	3.4000	14.3900
30.3800	3.4000	15.3260
31.3800	3.4000	15.3910
32.3800	3.4000	15.1470
33.3800	3.4000	15.1740

2.6.15 Copy XYZ → UVW

Translates XY coordinates to UV coordinates. This feature is useful for foam cutters, where second tower uses UV coordinates for its motion.

2.6.16 Copy UVW → XYZ

Translates UVW coordinates to XYZ coordinates.

2.6.17 Swap XYZ ↔ UVW

Swaps UVW coordinates with XYZ coordinates and vice versa.

2.6.18 Copy to Clipboard

Copies entire content of the G-Code panel to the Windows clipboard.

2.6.19 Paste from Clipboard

Pastes Windows clipboard content to the G-Code panel.

2.7 Machine Menu

Provides means to directly interact with controlled machine and attached hardware.

Emergency Stop	Escape
Start	
Stop	
Pause	Backspace
Start	▶
Overrides	▶
Mist	
Flood	
Spindle	▶
Output	▶
Motors, Limits, Probe	▶
Tools	▶
Move	▶
Machine Position	▶
Work Position	▶
Coordinate System	▶
Tool Offset	▶
Home	
Measure	▶
Points	▶
Camera	▶
User Commands	▶
Controller	▶

2.7.1 Emergency stop

Sends an Emergency stop or E-Stop to the machine causing immediate 'hard' stop. Controller stops sending control signals to motor driver.

Note: Using only E-Stop is not sufficient security solution when using servomotors. E-Stop doesn't prevent machine from crashing if encoder starts to send faulty data to motor driver. Some sort of double prevention system should be used for full-proof security solution, where e-Stop signal would trigger relays that would disconnect the power supply to the motors and limit switches would only serve as reference switches.

2.7.2 Start

Starts execution of the current G-Code program.

2.7.3 Stop

Stops program execution using a normal stop.

2.7.4 Pause

Pauses / Resumes execution of the current G-Code program.

2.7.5 Start

Emergency Stop	Escape	
Start		
Stop		
Pause	Backspace	
Start		Start From Selected Line
Overrides		Start From Bookmark To Bookmark
		Start From Beginning To Bookmark
		Start From Bookmark To End
Mist		
Flood		
Spindle		Start Loop ...
Output		
Motors, Limits, Probe		
Tools		
Move		
Machine Position		
Work Position		
Coordinate System		
Tool Offset		
Home		
Measure		
Points		
Camera		
User Commands		
Controller		

2.7.5.1 Start From Selected Line

Program will start at selected g-code line in g-code panel.

2.7.5.2 Start From Bookmark To Bookmark

Executes program from first bookmarked line to last bookmarked line. First and last bookmarked lines are included in execution.

2.7.5.3 Beginning to Bookmark

Executes program from first G-code line to first bookmarked line. Bookmarked line is included in execution.

2.7.5.4 Start From Bookmark to End

Executes program from first bookmark to last G-code line. Bookmarked line is included in execution.

2.7.5.5 Start Loop

Starts looped execution of the current G-Code program.

Inserted value represents number of loops of the G-code program.

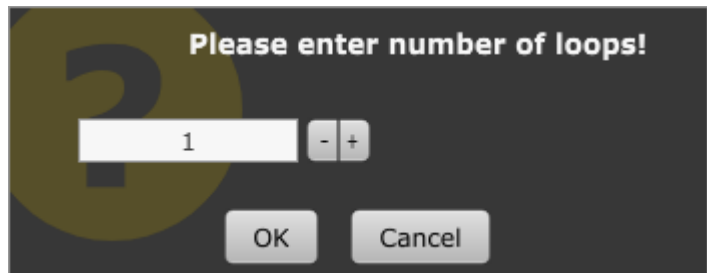

2.7.6 Overrides

Emergency Stop	Escape
Start	
Stop	
Pause	Backspace
Start	▶
Overrides	▶
Mist	
Flood	
Spindle	▶
Output	▶
Motors, Limits, Probe	▶
Tools	▶
Move	▶
Machine Position	▶
Work Position	▶
Coordinate System	▶
Tool Offset	▶
Home	
Measure	▶
Points	▶
Camera	▶
User Commands	▶
Controller	▶

✓ Speed Override Enable
Traverse ▶
Feed ▶
✓ Spindle Override Enable
Spindle ▶
✓ Pause Enable
Pause Optional
Single Step

2.7.6.1 Speed Override Enable

Enables traverse and feed speed override options. When this item is disabled (no check), override controls through either Override menu or Speed segment will have no effect on speed values.

When speed override is disabled, the speed dial icon is using red color:

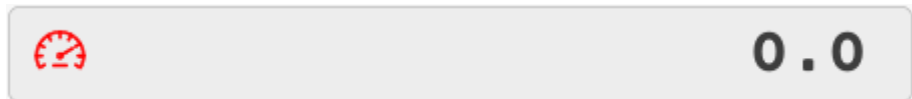

2.7.6.2 Traverse

Overrides speed setting for *Traverse* speed. Default traverse speed value is set in settings: *File/Setting/Program Defaults/Traverse Speed*.

Speed override controls are available also in Speed panel of main window.

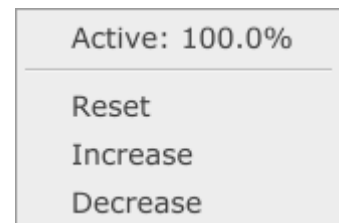

Active: Current override speed value. 100% means there is no speed override used. 200% means speed is overridden for 100%.

E.g.: If speed is set to 100mm/min and *Current* value is 200%, overridden traverse speed value is 200mm/min.

Reset: Resets any speed override.

Increase: Increases speed override setting for 10%.

Decrease: Decreases speed override setting for 10%.

2.7.6.3 Feed

Overrides speed setting for *Feed* speed. Feed speed setting is set in in g-code program with F-word or in settings: *File/Setting/Program Defaults/Feed Speed*. Speed override controls are available also in Speed panel of main window.

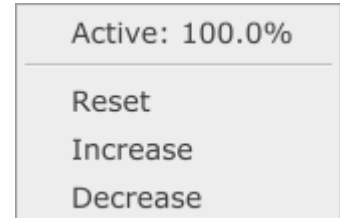

Active: Current override speed value. 100% means there is no speed override used. 200% means speed is overridden for 100%.

E.g.: If speed is set to 100mm/min and *Current* value is 200%, overridden feed speed value is 200mm/min.

Reset: Resets any speed override.

Increase: Increases speed override setting for 10%.

Decrease: Decreases speed override setting for 10%.

2.7.6.4 Spindle Override Enable

Enables spindle speed override options. When this item is disabled (no check), override controls through either Override menu or speed segment will have no effect on spindle speed values.

When spindle speed override is disabled, the spindle icon is using red color:

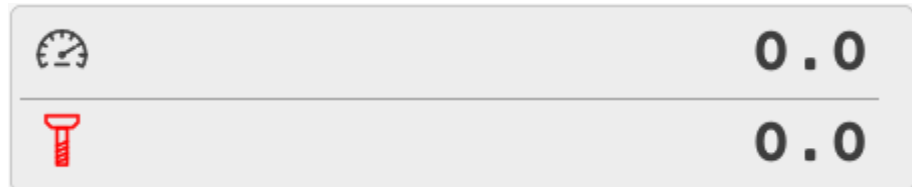

2.7.6.5 Spindle

Overrides speed setting for *Spindle* speed. Spindle speed setting is set in in g-code program with S-word or in settings: *File/Setting/Program Defaults/Spindle Speed*. Speed override controls are available also in Speed panel of main window.

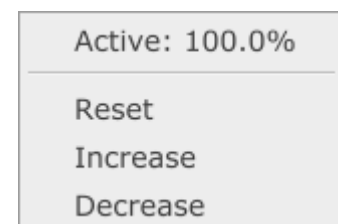

Active: Current override speed value. 100% means there is no speed override used. 200% means speed is overridden for 100%.

E.g.: If speed is set to 1000RPM and *Current* value is 200%, overridden spindle speed value is 2000RPM.

Reset: Resets any speed override.

Increase: Increases speed override setting for 10%.

Decrease: Decreases speed override setting for 10%.

2.7.6.6 *Pause Enable*

When *Pause Enable* is enabled, pause button from toolbar will activate pause. When this option is disabled (unchecked), pause button will not activate pause. This is meant as a safety feature, for scenarios where synchronised motion is crucial e.g. thread cutting.

Pause button is disabled:



2.7.6.7 *Pause optional*

When *Pause Optional* option is enabled, g-code *M01* pauses program. If this option is disabled, software continues with program execution and ignores *M01* g-code line.

2.7.6.8 *Single Step*

Enables single step execution of g-code program.

Each program line is executed separately, for which user needs to release *Pause* for each new program line to be executed.

2.7.7 Mist

Toggles *Mist* output pin. When *Mist* output is active, there is check next to Mist menu item as also corresponding output pin in Machine/Outputs menu. Toolbar button for Mist is also active.

M-code M07/M09 status is activated accordingly.

2.7.8 Flood

Toggles *Flood* output pin. When *Flood* output is active, there is check next to Flood menu item as also corresponding output pin in Machine/Outputs menu. Toolbar button for Flood is also active.

M-code M08/M09 status is activated accordingly.

2.7.9 Spindle

Toggles *Spindle* output pin. When *Spindle* output is active, there is check next to Spindle menu item as also corresponding output pin in Machine/Outputs menu. Toolbar button for Spindle is also active.

M-code M03/M05 status is activated accordingly.

2.7.10 Output

Controls digital outputs of controller via sub-menu.

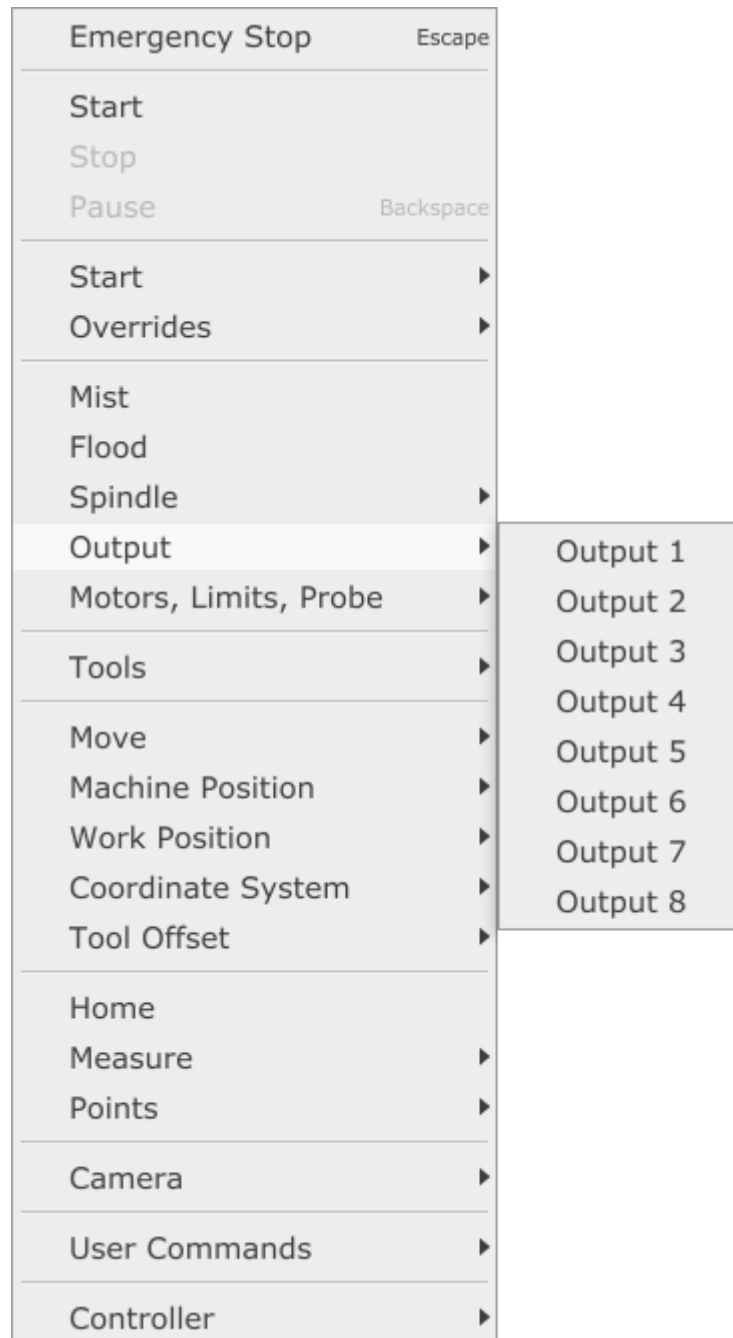

2.7.10.1 Output 1-8:

Selected digital output pin can be activated or deactivated. When output is active, there is check next to Output pin menu item. Active output pin will also be indicated under IO tab on the main screen.

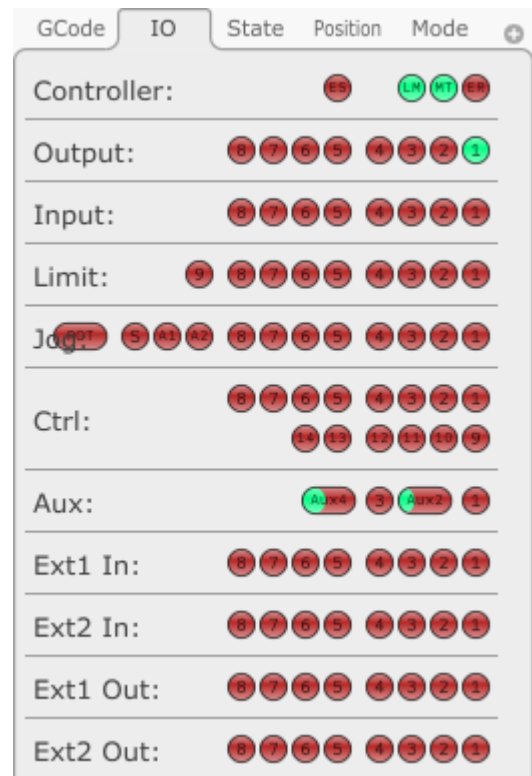
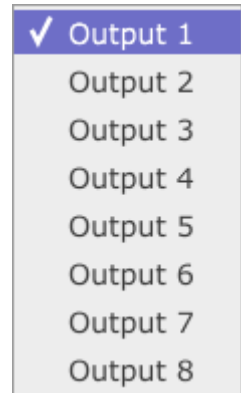

2.7.11 Motors, Limits, Probe

Emergency Stop	Escape
Start	
Stop	
Pause	Backspace
Start	▶
Overrides	▶
Mist	
Flood	
Spindle	▶
Output	▶
Motors, Limits, Probe	▶
Tools	▶
Move	▶
Machine Position	▶
Work Position	▶
Coordinate System	▶
Tool Offset	▶
Home	
Measure	▶
Points	▶
Camera	▶
User Commands	▶
Controller	▶

✓ Motors Enable
✓ Soft Limits Enable
✓ Hard Limits Enable
Probe Trigger

2.7.11.1 Motors Enable

Enables/disables *Enable* signal on controller axis headers.

NOTE: MT LED indicator will turn red when this option is disabled.

With *Motors Enable* enabled:



With *Motors Enable* disabled:



2.7.11.2 Soft Limits Enable

Enables/disables software limits of machine. Machine will be able to move outside of software limits set with *Motor Limits*. Motor limit values are set in *File/Settings/Motors/Limits*

2.7.11.3 Hard Limits Enable

Enables/disables hardware limits (limit switches) and probe inputs of machine. Machine axes will move despite corresponding axis limit switch or probe input being active. Limits switch parameters are set in *File/Settings/Motors/Limit Switches*; Probe parameters are set: *File/Settings/Program Options/Probe&Measure*

NOTE: LM LED indicator will turn red when this option is enabled

With *Hard Limits* enabled:



With *Ignore Hard Limits* disabled:



2.7.11.4 Probe Trigger

Simulates active probe input. You can use shortcut for this feature for easier use.

This feature comes very handy in case if you use PlanetCNC TNG in simulation mode where user need to simulate hardware probe input.

2.7.12 Tools

Provides means for changing and selecting tool as also editing a tool table.

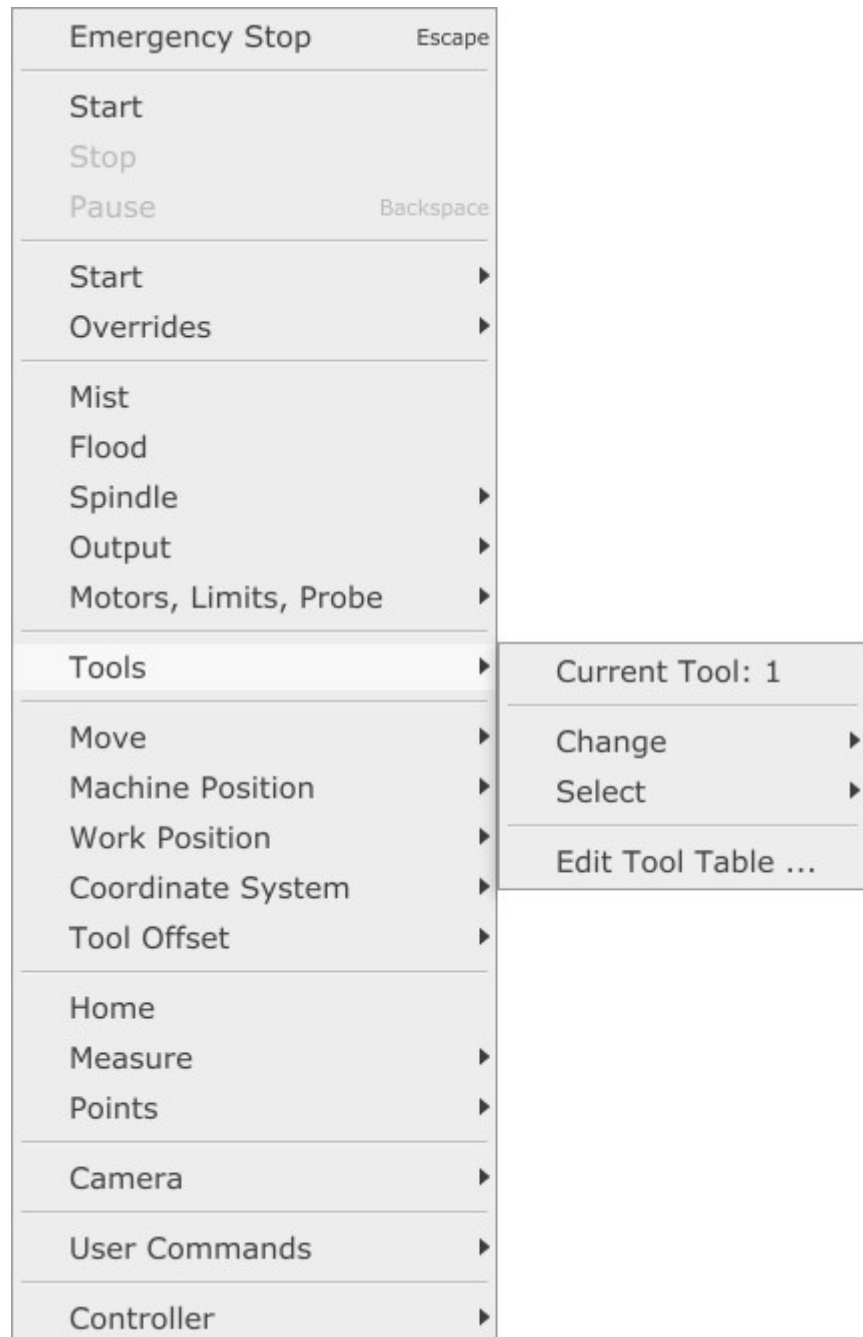

2.7.12.1 Current Active Tool

Displays current active tool.



2.7.12.2 Change

This program feature is script-able. For more info regarding Scripts, please read chapters Scripts(3.0) and Settings/Scripts(2.9.8.10)

Initiates tool change procedure. Newly changed tool will be set as active tool. If tool table is created, user can select tool from sub-menu. Equivalent to *Change* action is *M6* g-code.

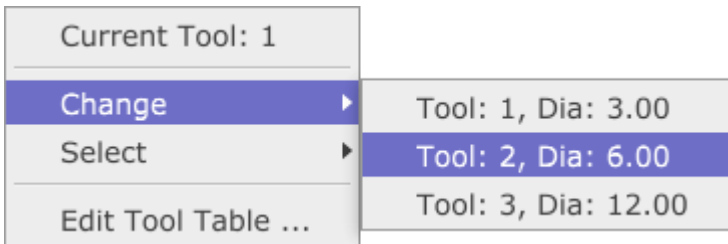

Newly active tool upon tool change to Tool 2:

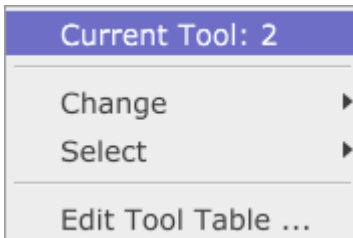

2.7.12.3 Select

This program feature is script-able. For more info regarding Scripts, please read chapters Scripts(3.0) and Settings/Scripts(2.9.8.10)

Sets active tool without tool change procedure. If tool table is created, user can select tool from sub-menu. Equivalent to Select action is M61 Qn g-code, where 'n' is tool number.

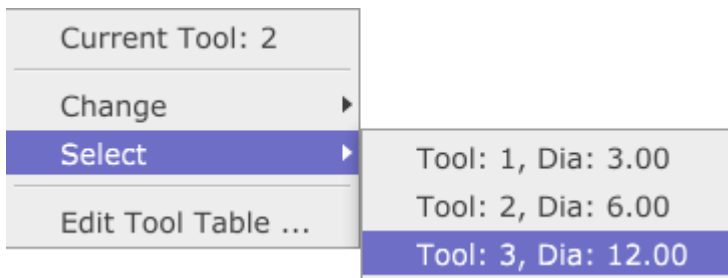

Newly active tool upon selecting Tool 3:

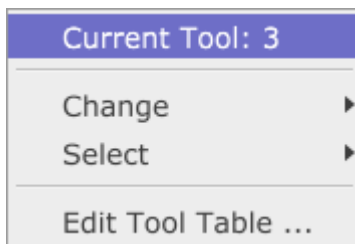

2.7.12.4 Edit Tool Table

Creates tool table with predefined diameters and offsets.

Tool Table
✕

1 : Tool 1
 2 : Tool 2
 3 : Tool 3
 4 : Tool 4

Tool

No: Diameter:

Name:

Offset

X: Y: Z:

A: B: C:

U: V: W:

Toolchange Position

X: Y: Z:

Sensor Offset

X: Y: Z:

Custom Parameters

1: 3: 5:

2: 4: 6:

Skip Tool Measure: Skip Tool Change:

2.7.12.4.1 Tool

Tool Table
✕

1 : Drill bit 3mm
2 : Ball Nose 6mm
3 : End Mill 8mm

Tool

No: Diameter:

Name:

Offset

X: Y: Z:

A: B: C:

U: V: W:

Toolchange Position

X: Y: Z:

Sensor Offset

X: Y: Z:

Custom Parameters

1: 3: 5:

2: 4: 6:

Skip Tool Measure: Skip Tool Change:

No:

Sets number of tool. User can choose from numbers 1-255.

Number can be set directly by writing into insert bar or with '+' and '-' buttons.

If tool number entered is the same as one of the tools that is already populated in tool table, then that tool will be highlighted in tool list:

Diameter:

Sets diameter of tool. User can choose from numbers 1-10000.

Number can be set directly by writing into insert bar or with '+' and '-' buttons.

Tools diameter value will be visible in *Change* and *Select* sub-menu:

Tool: 1, Dia: 3.00, Drill bit 3mm
Tool: 2, Dia: 6.00, Ball Nose 6mm
Tool: 3, Dia: 12.00, End Mill 8mm

This diameter value will be considered when G41 and G42. (Please note that these G-codes are not currently supported.)

Name:

Sets name of tool.

Tool Table
✕

1 : Drill bit 3mm

2 : Ball Nose 6mm

3 : End Mill 8mm

Tool

No: Diameter:

Name:

Offset

X: Y: Z:

A: B: C:

U: V: W:

Toolchange Position

X: Y: Z:

Sensor Offset

X: Y: Z:

Custom Parameters

1: 3: 5:

2: 4: 6:

Skip Tool Measure: Skip Tool Change:

Tool name will be visible in tool table list as also in *Change* and *Select* sub-menu:

- Tool: 1, Dia: 3.00, Drill bit 3mm
- Tool: 2, Dia: 6.00, Ball Nose 6mm
- Tool: 3, Dia: 12.00, End Mill 8mm

2.7.12.4.2 Offset

X,Y,Z,A,B,C,U,V,W:

Sets tool offset of tool. Offset can be set in all 9 axes.

2.7.12.4.3 Tool Change Position

These are position values of selected tool. When manual or automatic tool change is initiated machine will use these position values in order to mount or dismount requested tool.

These values are also available as parameters so you can use them in any way you want or need when configuring tool change script file.

2.7.12.4.4 Sensor Offset

If measured tool uses e.g. cutting flutes that are eccentric to tools geometry and machine would need to measure it with an eccentric offset value, then this value represents machine offset so that tool can be successfully measured.

2.7.12.4.5 Custom Parameters

Custom parameters that can be used in tool change script configuration.

2.7.12.4.6 Skip Tool Measure

When enabled, then tool will not be measured with fixed tool sensor e.g. Probe.

2.7.12.4.7 Skip Tool Change

When enabled, then tool will not use tool change procedure e.g. Laser.

2.7.12.4.8 Add

This button creates and adds tool to tool table.

2.7.12.4.9 Update

This button updates any configuration changes of selected tool from tool table.

2.7.12.4.10 Delete

This button deletes selected tool from tool table.

2.7.12.4.11 Import...

With PlanetCNC TNG user can save tool table as tool table file.

Import button imports tool table file.

2.7.12.4.12 Export...

With PlanetCNC TNG user can save tool table as tool table file.

Export button exports tool table file.

2.7.12.4.13 OK

This button confirms changes and closes Edit Tool Table dialog.

PLEASE NOTE:

To create and add new tool to tool table, user needs to use Add button.

If configuration changes were made to existing tools from tool table, user still needs to use Update button.

2.7.12.4.14 Cancel

This button cancels changes and closes Edit Tool Table dialog.

Example: Creating a new tool in the tool table

Click *Machine/Tools/Edit Tool Table*. Under Tool No.: insert number for new tool. Insert *Diameter* value and its name. Insert tool offset (usually only in Z axis). Then click *Add*. Tool will appear in the tool list.

To change parameters of already created tool select tool from tool list and change tools parameters. Then click *Update*.

2.7.13 Move

Provides means to move all machine axes or selected axis/axes to zero or predefined position values.

Emergency Stop	Escape
Start	
Stop	
Pause	Backspace
Start	▶
Overrides	▶
Mist	
Flood	
Spindle	▶
Output	▶
Motors, Limits, Probe	▶
Tools	▶
Move	▶
Machine Position	▶
Work Position	▶
Coordinate System	▶
Tool Offset	▶
Home	
Measure	▶
Points	▶
Camera	▶
User Commands	▶
Controller	▶

To Zero	
To ...	
Axis To Zero	▶
To G28	
To G30	
To Selected Line	
To Selected Line XY	
Position To Camera	
Camera To Position	
Camera To Selected Line XY	

2.7.13.1 To Zero

This program feature is script-able. For more info regarding Scripts, please read chapters Scripts(3.0) and Settings/Scripts(2.9.8.10)

Moves all machine axes to zero position value. If no *Work Offset* is set machine will move to absolute zero. If *Work Offset* is set, machine will move to zero *Work Position*.

2.7.13.2 To...

This program feature is script-able. For more info regarding Scripts, please read chapters Scripts(3.0) and Settings/Scripts(2.9.8.10)

Provides means to move selected axis/axes to desired position.

You can move all 9 axes: **X,Y,Z,A,B,C,U,V,W**. To confirm a move of selected axis to specified position, enable axis radio button, insert axis position and click OK.

E.g.: Move machine axes X,Y and Z to positions 20,30,50:

The image shows a 'Move' dialog box with the following fields and controls:

- X:
- Y:
- Z:
- A:
- B:
- C:
- U:
- V:
- W:
- Copy From:
- OK
- Cancel

2.7.13.2.1 Copy From

This program feature is script-able. For more info regarding Scripts, please read chapters Scripts(3.0) and Settings/Scripts(2.9.8.10)

With *Copy From* user can choose among options provided from drop down menu for faster population of axis position values.

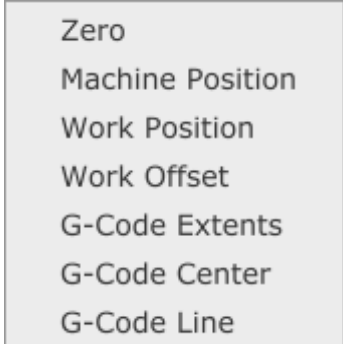

Zero
Machine Position
Work Position
Work Offset
G-Code Extents
G-Code Center
G-Code Line

Zero:

Populates all position values of *Move* dialog with zero values.

Absolute Position:

Populates all position values of *Move* dialog with machines current absolute position values.

Work Position:

Populates all position values of *Move* dialog with machines current working position values.

Work Offset:

Populates all position values of *Move* dialog with current working offset values.

G-Code Extents:

Populates all position values of *Move* dialog with g-code program extent values.

s

G-Code Center:

Populates all position values of *Move* dialog with g-code program center values. G-code centre position is a position in the centre of g-code toolpath.

G-Code Line:

Populates all position values of *Move* dialog with coordinate values of selected g-code line from g-code window.

2.7.13.3 Axis to Zero

This program feature is script-able. For more info regarding Scripts, please read chapters Scripts(3.0) and Settings/Scripts(2.9.8.10)

Moves selected machine axis to zero position value. If no *Work Offset* is set for selected axis, axis will move to absolute zero position value. If *Work Offset* is set for selected axis, axis will move to axis zero *Work Position*.

User can select axis from sub menu:

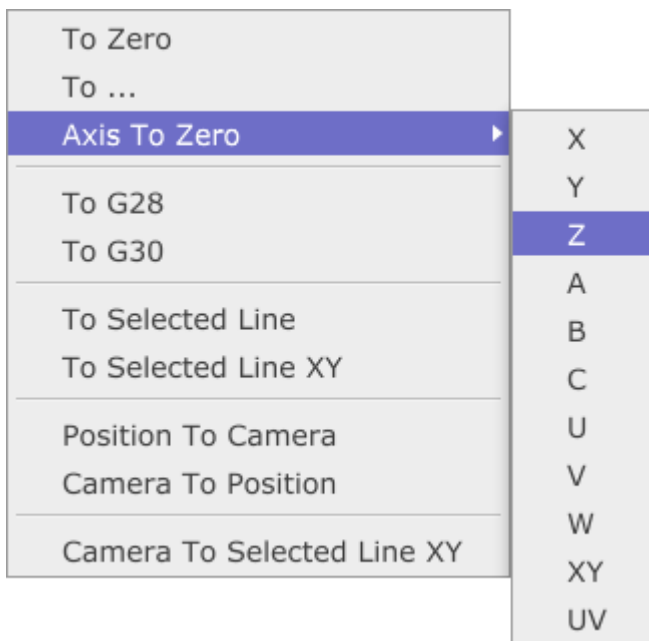

2.7.13.4 To G28

This program feature is script-able. For more info regarding Scripts, please read chapters Scripts(3.0) and Settings/Scripts(2.9.8.10)

Moves machine to G28 position (preset absolute machine position). To set G28 absolute position value see chapter 2.5.13.6 As G28.

2.7.13.5 To G30

This program feature is script-able. For more info regarding Scripts, please read chapters Scripts(3.0) and Settings/Scripts(2.9.8.10)

Moves machine to G30 position (preset absolute machine position). To set G30 absolute position value see chapter 2.5.13.7 As G30.

2.7.13.6 To Selected Line

This program feature is script-able. For more info regarding Scripts, please read chapters Scripts(3.0) and Settings/Scripts(2.9.8.10)

Moves machine to position of selected g-code line in g-code window.

2.7.13.7 To Selected Line XY

This program feature is script-able. For more info regarding Scripts, please read chapters Scripts(3.0) and Settings/Scripts(2.9.8.10)

Moves machine to XY position value of selected g-code line in g-code window.

2.7.13.8 Position to Camera

This program feature is script-able. For more info regarding Scripts, please read chapters Scripts(3.0) and Settings/Scripts(2.9.8.10)

Moves machine to XY position of camera view.

2.7.13.9 Camera To Position

This program feature is script-able. For more info regarding Scripts, please read chapters Scripts(3.0) and Settings/Scripts(2.9.8.10)

Camera view moves to current machine position.

2.7.13.10 Camera To Selected Line XY

This program feature is script-able. For more info regarding Scripts, please read chapters Scripts(3.0) and Settings/Scripts(2.9.8.10)

Camera view moves to XY position value of selected g-code line from g-code window.

2.7.14 Machine Position

Emergency Stop	Escape
Start	
Stop	
Pause	Backspace
Start Options	▶
Overrides	▶
Mist	
Flood	
Spindle	▶
Output	▶
Motors, Limits, Probe	▶
Tools	▶
Move	▶
Machine Position	▶
Work Position	▶
Coordinate System	▶
Tool Offset	▶
Home	
Measure	▶
Points	▶
Camera	▶
User Commands	▶
Controller	▶

To Zero
To ...
Axis To Zero ▶
Unwind ▶
As G28
As G30
Reset THC

2.7.14.1 To Zero

This program feature is script-able. For more info regarding Scripts, please read chapters Scripts(3.0) and Settings/Scripts(2.9.8.10)

Sets all machine position values to zero, none of the axes will move during this action.

2.7.14.2 To...

This program feature is script-able. For more info regarding Scripts, please read chapters Scripts(3.0) and Settings/Scripts(2.9.8.10)

When dialogue is displayed, current machine position values are already populated.

You can set new machine position values for each of 9 axes: **X,Y,Z,A,B,C,U,V,W**.

To set new machine position for selected axis, enable axis radio button, insert new machine position and click OK.

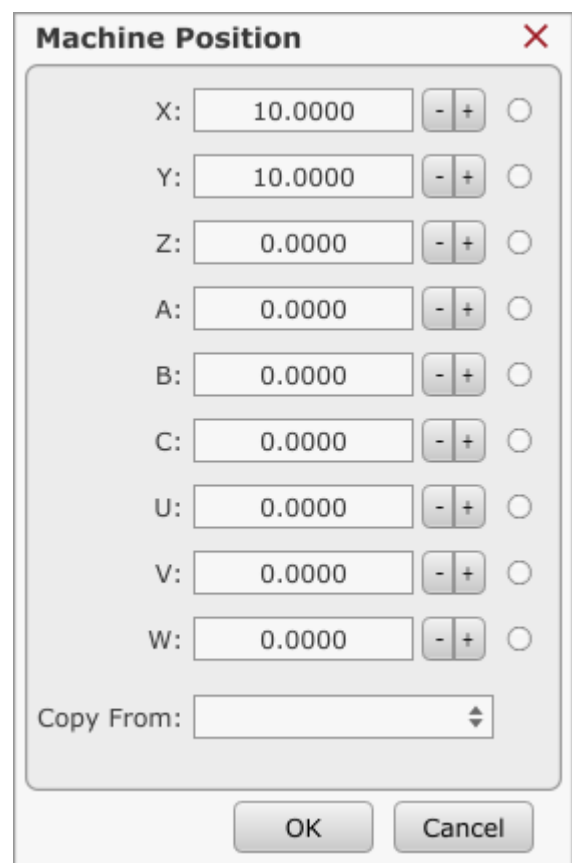

The image shows a dialog box titled "Machine Position" with a close button (X) in the top right corner. The dialog contains nine rows, each representing an axis: X, Y, Z, A, B, C, U, V, and W. Each row has a text input field for the position value, a pair of buttons labeled "-" and "+" for manual adjustment, and a radio button to the right. The current values are: X: 10.0000, Y: 10.0000, Z: 0.0000, A: 0.0000, B: 0.0000, C: 0.0000, U: 0.0000, V: 0.0000, and W: 0.0000. At the bottom of the dialog, there is a "Copy From:" label followed by a dropdown menu. Below the dialog are two buttons: "OK" and "Cancel".

2.7.14.2.1 Copy From

With *Copy From* option, user can choose among options provided from drop down menu for faster population of machine position values.

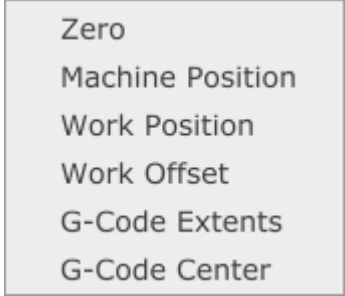

- Zero
- Machine Position
- Work Position
- Work Offset
- G-Code Extents
- G-Code Center

Zero:

Populates all machine position values of *Machine position* dialog with zero values.

Machine Position:

Populates all machine position values of *Machine position* dialog with current machine position values.

Work Position:

Populates all machine position values of *Machine position* dialog with current work position values.

Work Offset:

Populates all machine position values of *Machine position* dialog with current work offset values.

G-Code Extents:

Populates all machine position values of *Machine position* dialog with g-code program extent values.

G-Code Center:

Populates all machine position values of *Machine position* dialog with g-code program center values.

2.7.14.3 Axis To Zero

This program feature is script-able. For more info regarding Scripts, please read chapters Scripts(3.0) and Settings/Scripts(2.9.8.10)

Sets machine position value of selected axis to zero. User can select axis or axes from drop down menu:

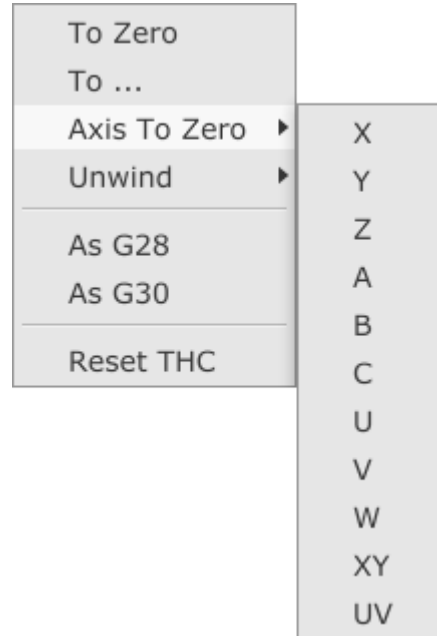

2.7.14.4 Unwind ABC

When rotary axis has a high position value (e.g. 1000 deg), and you would need to rotate it back to zero position, you can use Unwind feature. This will automatically set rotary machine position to much lower value, and therefore avoid unnecessary full circle(360 deg) axis rotations and time consumption. You unwind axis separately or all three at the same time.

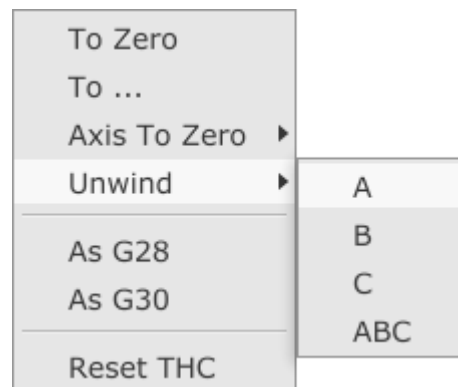

2.7.14.5 As G28

This program feature is script-able. For more info regarding Scripts, please read chapters Scripts(3.0) and Settings/Scripts(2.9.8.10)

Sets current machine position as G28 position.

2.7.14.6 As G30

This program feature is script-able. For more info regarding Scripts, please read chapters Scripts(3.0) and Settings/Scripts(2.9.8.10)

Sets current machine position as G30 position.

2.7.15 Work Position

Emergency Stop	Escape
Start	
Stop	
Pause	Backspace
Start	▶
Overrides	▶
Mist	
Flood	
Spindle	▶
Output	▶
Motors, Limits, Probe	▶
Tools	▶
Move	▶
Machine Position	▶
Work Position	▶
Coordinate System	▶
Tool Offset	▶
Home	
Measure	▶
Points	▶
Camera	▶
User Commands	▶
Controller	▶

To Zero
To ...
Axis To Zero ▶
Measure Height
Offset ▶
Selected Line
Selected Line XY
Camera XY

2.7.15.1 To Zero

This program feature is script-able. For more info regarding Scripts, please read chapters Scripts(3.0) and Settings/Scripts(2.9.8.10)

Sets all work position values to zero, none of the axes will move during this action.

2.7.15.2 To...

This program feature is script-able. For more info regarding Scripts, please read chapters Scripts(3.0) and Settings/Scripts(2.9.8.10)

When dialog is displayed, current working position values are already populated.

You can set new working position values for all 9 axes: **X,Y,Z,A,B,C,U,V,W**.

To set working position for selected axis, enable axis radio button, insert axis working position and click OK.

The screenshot shows a dialog box titled "Work Position" with a close button (X) in the top right corner. The dialog contains nine rows, each representing an axis: X, Y, Z, A, B, C, U, V, and W. Each row has a text input field containing a numerical value, a small numeric keypad with "-" and "+" buttons, and a radio button. The values for X, Y, and Z are 10.0000, while the values for A, B, C, U, V, and W are 0.0000. At the bottom of the dialog, there is a "Copy From:" dropdown menu and two buttons: "OK" and "Cancel".

2.7.15.2.1 Copy From

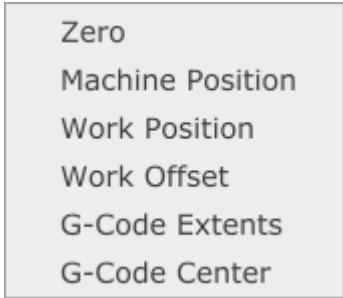

- Zero
- Machine Position
- Work Position
- Work Offset
- G-Code Extents
- G-Code Center

Zero:

Populates all working position values of *Work Position* dialog with zero values.

Machine Position:

Populates all working position values of *Work Position* dialog with current machine position values.

Work Position:

Populates all working position values of *Work Position* dialog with current work position values.

Work Offset:

Populates all working position values of *Work Position* dialog with current working offset values.

G-Code Extents:

Populates all working position values of *Work Position* dialog with g-code program extent values.

G-Code Center:

Populates all working position values of *Work Position* dialog with g-code program centre values.

2.7.15.3 Axis To Zero

This program feature is script-able. For more info regarding Scripts, please read chapters Scripts(3.0) and Settings/Scripts(2.9.8.10)

Sets working position value of selected axis to zero. User can select axis from sub menu:

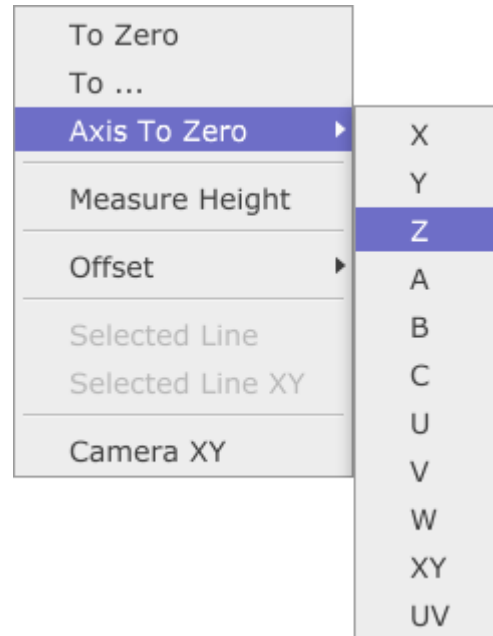

2.7.15.4 Measure Height

This program feature is script-able. For more info regarding Scripts, please read chapters Scripts(3.0) and Settings/Scripts(2.9.8.10)

Initiates *Work Position\Measure Height* procedure.

Z axis will start descending at current machine position and when sensor/probe input is activated, software sets work position of Z axis to zero.

Sensor configuration settings that respond to this program function are located:

File/Settings/Program Options/Offsets/Work Position/Measure Height

Please note: To avoid any damage, software safety feature will notify you if sensor/probe is not configured in *File/Settings/Program Options/Probe & Measure*

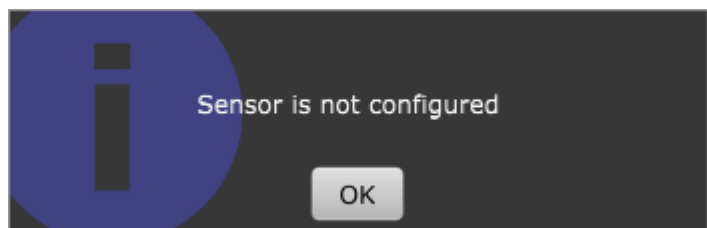

2.7.15.5 Offset

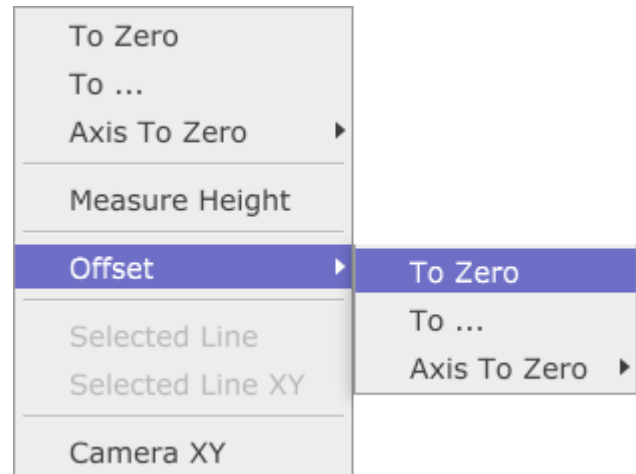

2.7.15.5.1 To Zero

This program feature is script-able. For more info regarding Scripts, please read chapters Scripts(3.0) and Settings/Scripts(2.9.8.10)

Sets Offset value to zero for all machine axes.

2.7.15.5.2 To...

This program feature is script-able. For more info regarding Scripts, please read chapters *Scripts(3.0)* and *Settings/Scripts(2.9.8.10)*

When dialog is displayed, current work offset values are already populated.

You can set work offset values for all 9 axes: **X,Y,Z,A,B,C,U,V,W**.

To set work offset for selected axis, enable axis radio button, insert axis work offset and click OK.

2.7.15.5.3 Copy From

Zero:

Populates all work offset values of *Offset* dialog with zero values.

Machine Position:

Populates all work offset values of *Offset* dialog with machines current machine position values.

Work Position:

Populates all work offset values of *Offset* dialog with machines current working position values.

Work Offset:

Populates all work offset values of *Offset* dialog with current working offset values.

2.7.15.5.4 Axis To Zero

This program feature is script-able. For more info regarding Scripts, please read chapters Scripts(3.0) and Settings/Scripts(2.9.8.10)

Sets selected machine axis work offset value to zero. User can select axis from sub menu:

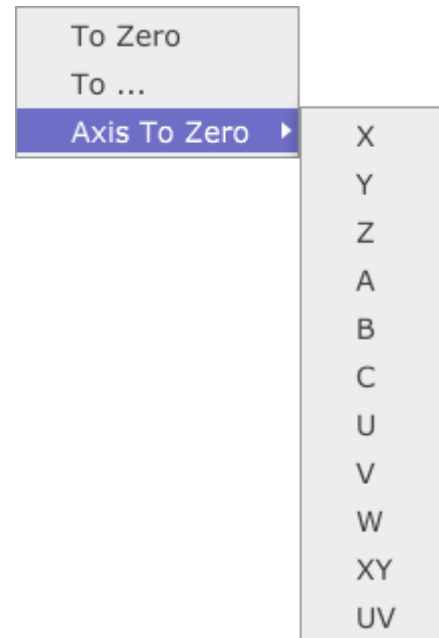

2.7.15.6 Selected Line

This program feature is script-able. For more info regarding Scripts, please read chapters Scripts(3.0) and Settings/Scripts(2.9.8.10)

Work position values of machine axes are set with position values of selected g-code line in g-code window.

2.7.15.7 Selected Line XY

This program feature is script-able. For more info regarding Scripts, please read chapters Scripts(3.0) and Settings/Scripts(2.9.8.10)

Work position values of machine XY axes are set with only XY position values of selected g-code line in g-code window.

2.7.15.8 Camera XY

This program feature is script-able. For more info regarding Scripts, please read chapters Scripts(3.0) and Settings/Scripts(2.9.8.10)

Work position values of machine XY axes are set with Camera view.

2.7.16 Coordinate System

With this group of settings you can select, configure, measure and edit coordinate systems.

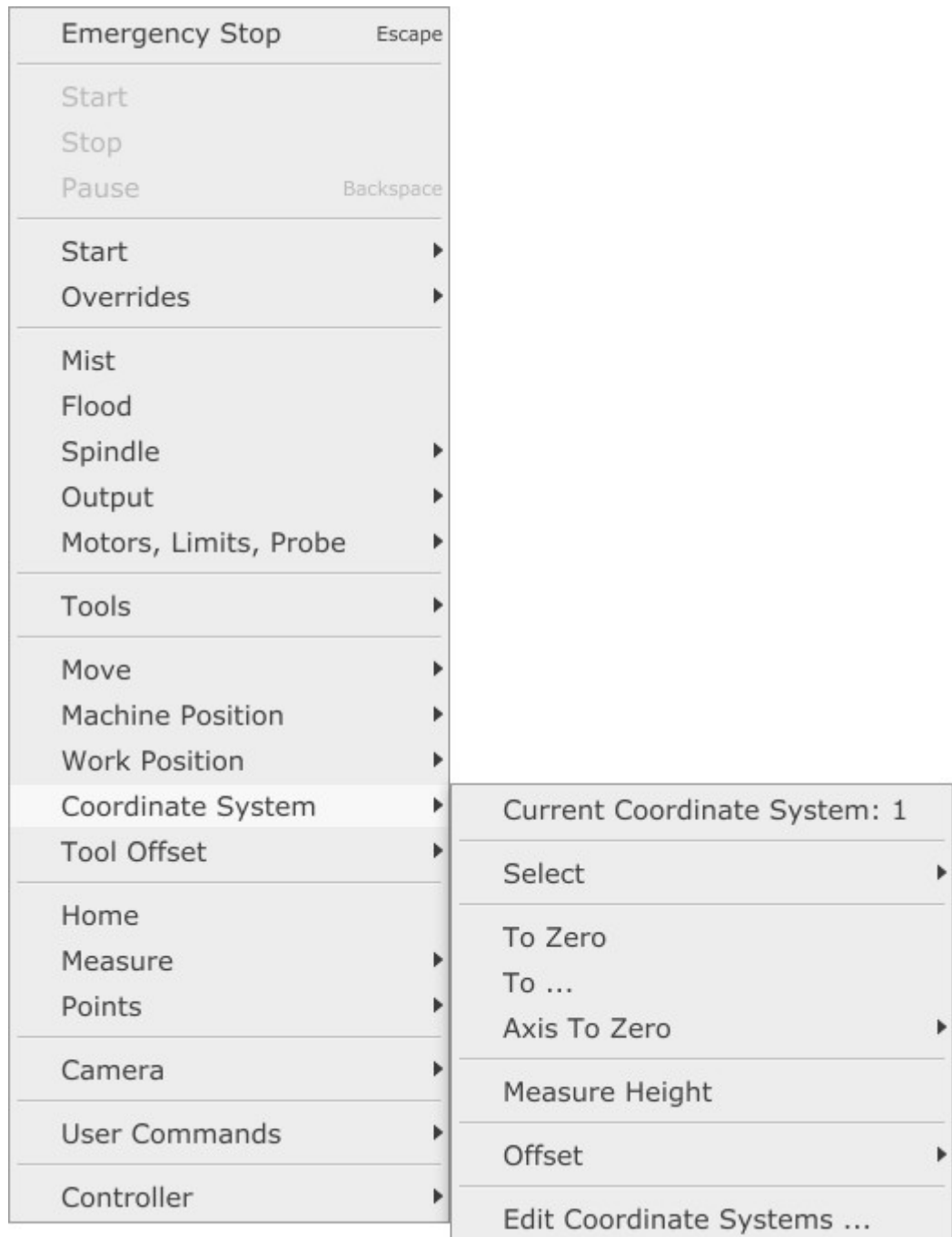

2.7.16.1 Current Coordinate System

Displays current active coordinate system. You can select active coordinate system either using the standard coordinate system g-codes *G54, G55, G56...* or using *Machine/Coordinate System/Select* feature.

2.7.16.2 Select

You can select active coordinate system number from drop down menu:

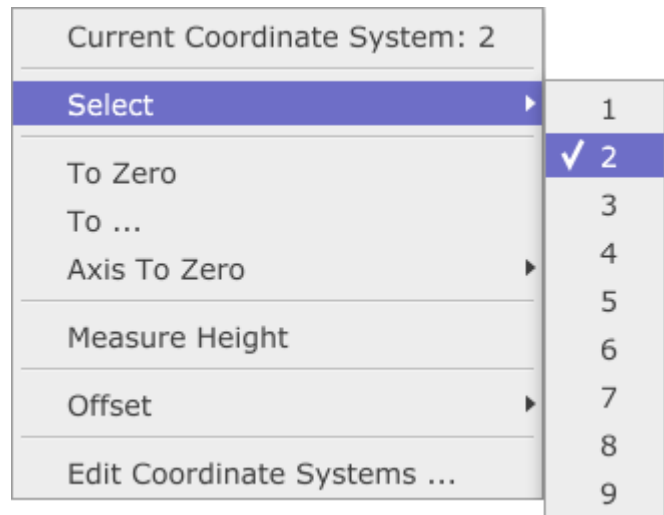

2.7.16.3 To Zero

Sets current work position to zero.

Coordinate system offset values of currently active coordinate system are set accordingly.

2.7.16.4 To...

When dialog is displayed, current work position values are already populated.

You can set new position values for all 9 axes: **X,Y,Z,A,B,C,U,V,W**.

To set new position value for selected axis, enable axis radio button, insert axis offset value and click OK.

Coordinate system offset values of currently active coordinate system will be set accordingly.

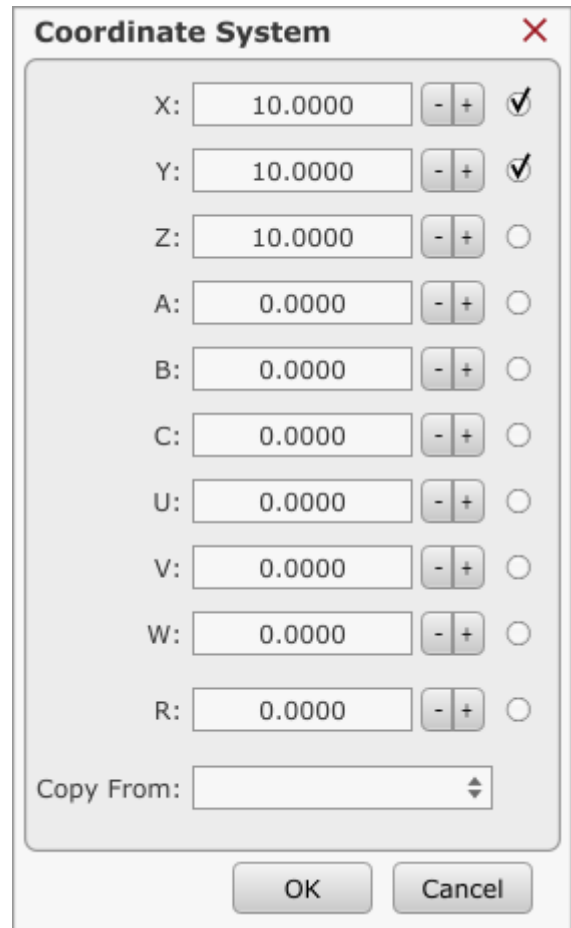

2.7.16.4.1 Copy From

Zero:

Populates all offset values of *Coordinate System* dialog with zero values.

Absolute Position:

Populates all offset values of *Coordinate System* dialog with machines current absolute position values.

Work Position:

Populates all offset values of *Coordinate System* dialog with machines current working position values.

Work Offset:

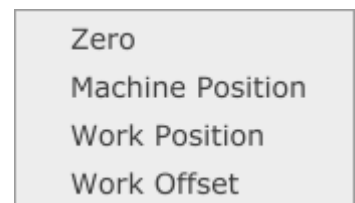

Populates all work offset values of *Coordinate System* dialog with current working offset values.

2.7.16.5 *Axis To Zero*

Sets work position value to zero for selected axis. User can select axis from sub menu:
Coordinate system offset values of currently active coordinate system will be set accordingly.

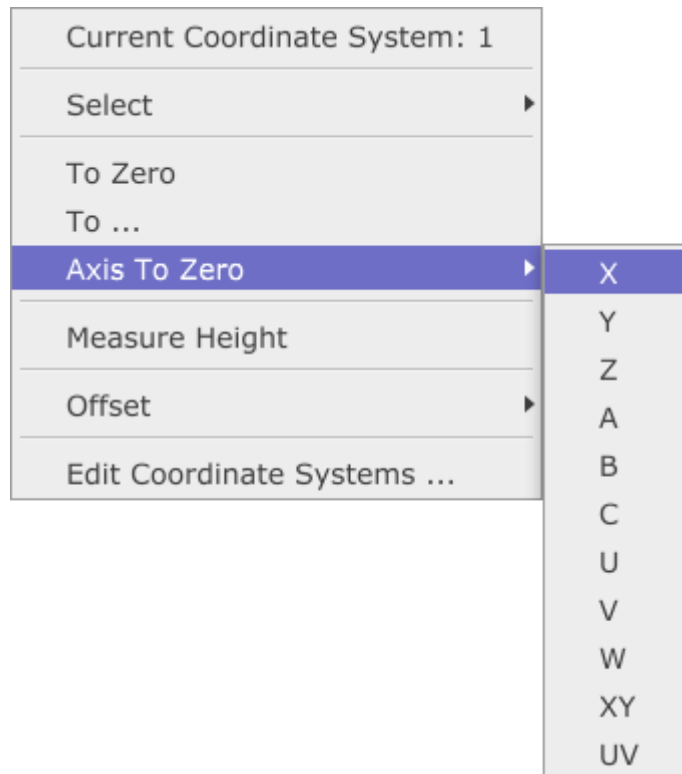

2.7.16.6 *Measure Height*

Measures Z axis offset value of active coordinate system.

Z axis will start descending at current position and when sensor/probe input is activated (e.g. surface of material), software sets Z axis offset of active coordinate system.

Sensor configuration settings that respond to this program function are located:

File/Settings/Program Options/Offsets/Work Position/Measure Height

Please note: To avoid any damage, software safety feature will notify you if sensor/probe is not configured in *File/Settings/Program Options/Probe & Measure*

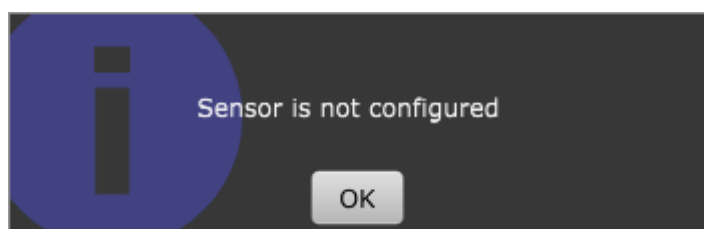

2.7.16.7 Offset

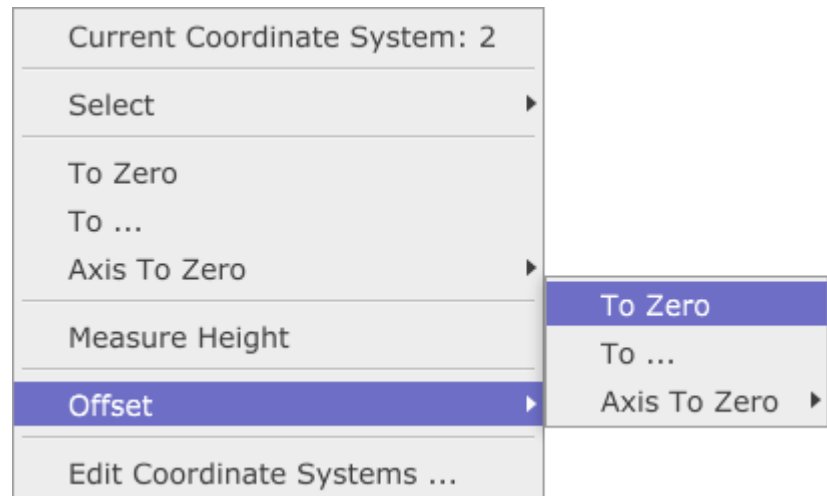

2.7.16.7.1 To Zero

This program feature is script-able. For more info regarding Scripts, please read chapters Scripts(3.0) and Settings/Scripts(2.9.8.10)

Sets coordinate system offset value to zero for all machine axes.

2.7.16.7.2 To...

This program feature is script-able. For more info regarding Scripts, please read chapters Scripts(3.0) and Settings/Scripts(2.9.8.10)

When dialog is displayed, current coordinate system offset values are already populated.

You can set coordinate system offset values for all 9 axes: **X,Y,Z,A,B,C,U,V,W**.

To set offset for selected axis, enable axis radio button, insert axis offset value and click OK.

Copy From:

Zero:

Populates all offset values of *Offset* dialog with zero values.

Machine Position:

Populates all offset values of *Offset* dialog with machines current machine position values.

Work Position:

Populates all offset values of *Offset* dialog with machines current working position values.

Work Offset:

Populates all offset values of *Offset* dialog with current working offset values.

2.7.16.7.3 Axis To Zero

This program feature is script-able. For more info regarding Scripts, please read chapters Scripts(3.0) and Settings/Scripts(2.9.8.10)

Sets selected machine axis coordinate system offset value to zero. User can select axis from sub menu:

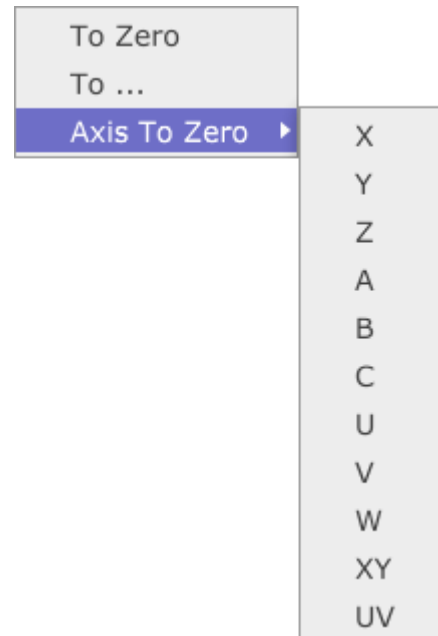

2.7.17 Tool Offset

Emergency Stop	Escape
Start	
Stop	
Pause	Backspace
Start	▶
Overrides	▶
Mist	
Flood	
Spindle	▶
Output	▶
Motors, Limits, Probe	▶
Tools	▶
Move	▶
Machine Position	▶
Work Position	▶
Coordinate System	▶
Tool Offset	▶
Home	
Measure	▶
Points	▶
Camera	▶
User Commands	▶
Controller	▶

✓ Enabled
To Zero
To ...
Axis To Zero ▶
Measure Length
From Tool Table

2.7.17.1 Enabled

Enables/disables offset of currently active tool. This function responds to G43/G49 g-codes.

G43:

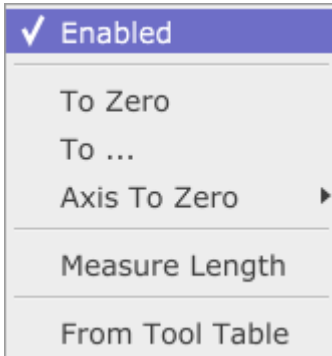

G49:

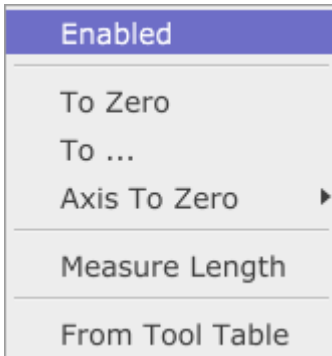

2.7.17.2 To Zero

This program feature is script-able. For more info regarding Scripts, please read chapters Scripts(3.0) and Settings/Scripts(2.9.8.10)

Sets Tool Offset value to zero for all machine axes.

2.7.17.3 To...

This program feature is script-able. For more info regarding Scripts, please read chapters Scripts(3.0) and Settings/Scripts(2.9.8.10)

When dialog is displayed, current tool offset values are already populated.

You can set tool offset values for all 9 axes: **X,Y,Z,A,B,C,U,V,W**.

To set tool offset for selected axis, enable axis radio button, insert axis tool offset and click OK.

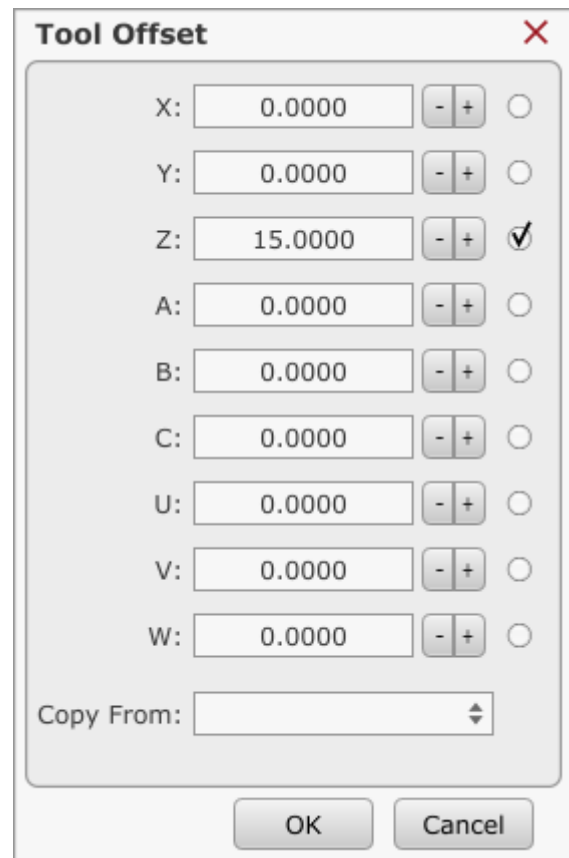

The screenshot shows a dialog box titled "Tool Offset" with a close button (X) in the top right corner. The dialog contains nine rows, each representing an axis: X, Y, Z, A, B, C, U, V, and W. Each row has a text input field for the offset value, a small button with "-" and "+" signs for incrementing/decrementing, and a radio button. The Z-axis row is selected, with a checkmark in its radio button and a value of 15.0000 in its input field. All other axes have a value of 0.0000. At the bottom of the dialog, there is a "Copy From:" label followed by a dropdown menu. Below the dialog are two buttons: "OK" and "Cancel".

Axis	Value	Radio Button
X:	0.0000	<input type="radio"/>
Y:	0.0000	<input type="radio"/>
Z:	15.0000	<input checked="" type="radio"/>
A:	0.0000	<input type="radio"/>
B:	0.0000	<input type="radio"/>
C:	0.0000	<input type="radio"/>
U:	0.0000	<input type="radio"/>
V:	0.0000	<input type="radio"/>
W:	0.0000	<input type="radio"/>

Copy From:

OK Cancel

2.7.17.3.1 Copy From

Zero:

Populates all tool offset values of *Tool Offset* dialog with zero values.

Machine Position:

Populates all tool offset values of *Tool Offset* dialog with machine position values.

Work Position:

Populates all tool offset values of *Tool Offset* dialog with machines current working position values.

Work Offset:

Populates all tool offset values of *Tool Offset* dialog with current working offset values.

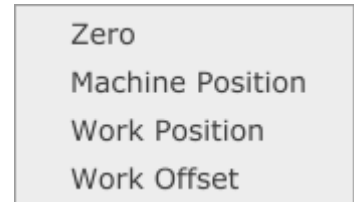

2.7.17.4 Axis to Zero

This program feature is script-able. For more info regarding Scripts, please read chapters Scripts(3.0) and Settings/Scripts(2.9.8.10)

Sets tool offset value of selected axis to zero. User can select axis from sub menu:

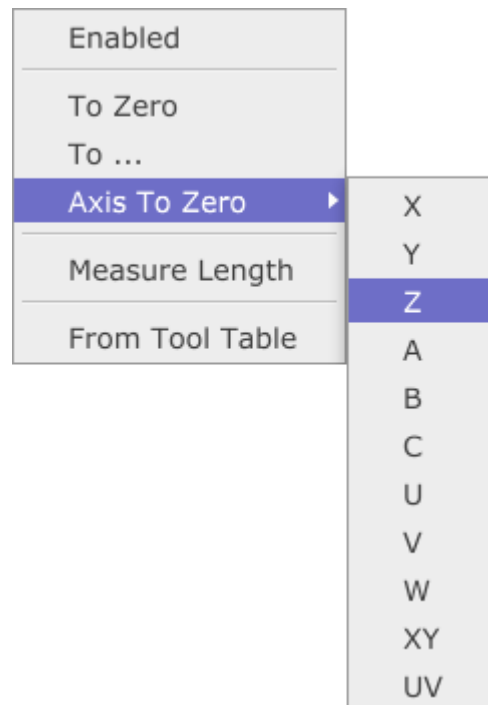

2.7.17.5 Measure Length

This program feature is script-able. For more info regarding Scripts, please read chapters Scripts(3.0) and Settings/Scripts(2.9.8.10)

Initiates *Measure Length* procedure.

Machine will move to fixed sensor position at safe height and proceed to measure tool length offset. Measured tool offset will be set.

Sensor configuration settings that respond to this program function are located:

File/Settings/Program Options/Offsets/Tool Offset/Measure Length

Please note: To avoid any damage, software safety feature will notify you if sensor/probe is not configured in *File/Settings/Program Options/Probe & Measure*

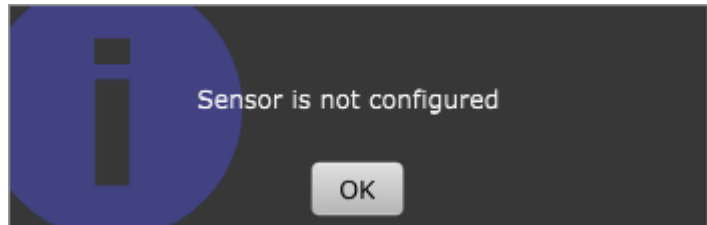

2.7.17.6 From Tool Table

This program feature is script-able. For more info regarding Scripts, please read chapters Scripts(3.0) and Settings/Scripts(2.9.8.10)

Sets *Tool Offset* value of current tool from tool table.

2.7.18 Home

This program feature is script-able. For more info regarding Scripts, please read chapters Scripts(3.0) and Settings/Scripts(2.9.8.10)

Initiates homing procedure. On how to configure homing procedure please refer to chapter 2.9.8.8. *Homing*

Emergency Stop	Escape
Start	
Stop	
Pause	Backspace
Start	▶
Overrides	▶
Mist	
Flood	
Spindle	▶
Output	▶
Motors, Limits, Probe	▶
Tools	▶
Move	▶
Machine Position	▶
Work Position	▶
Coordinate System	▶
Tool Offset	▶
Home	
Measure	▶
Points	▶
Camera	▶
User Commands	▶
Controller	▶

2.7.19 Measure

Provides means for machine measuring of various geometries. For such purpose user can use measurement probing device.

Please note:

Probe configuration settings that respond to these program functions are located:

File/Settings/Program Options/Probe&Measure

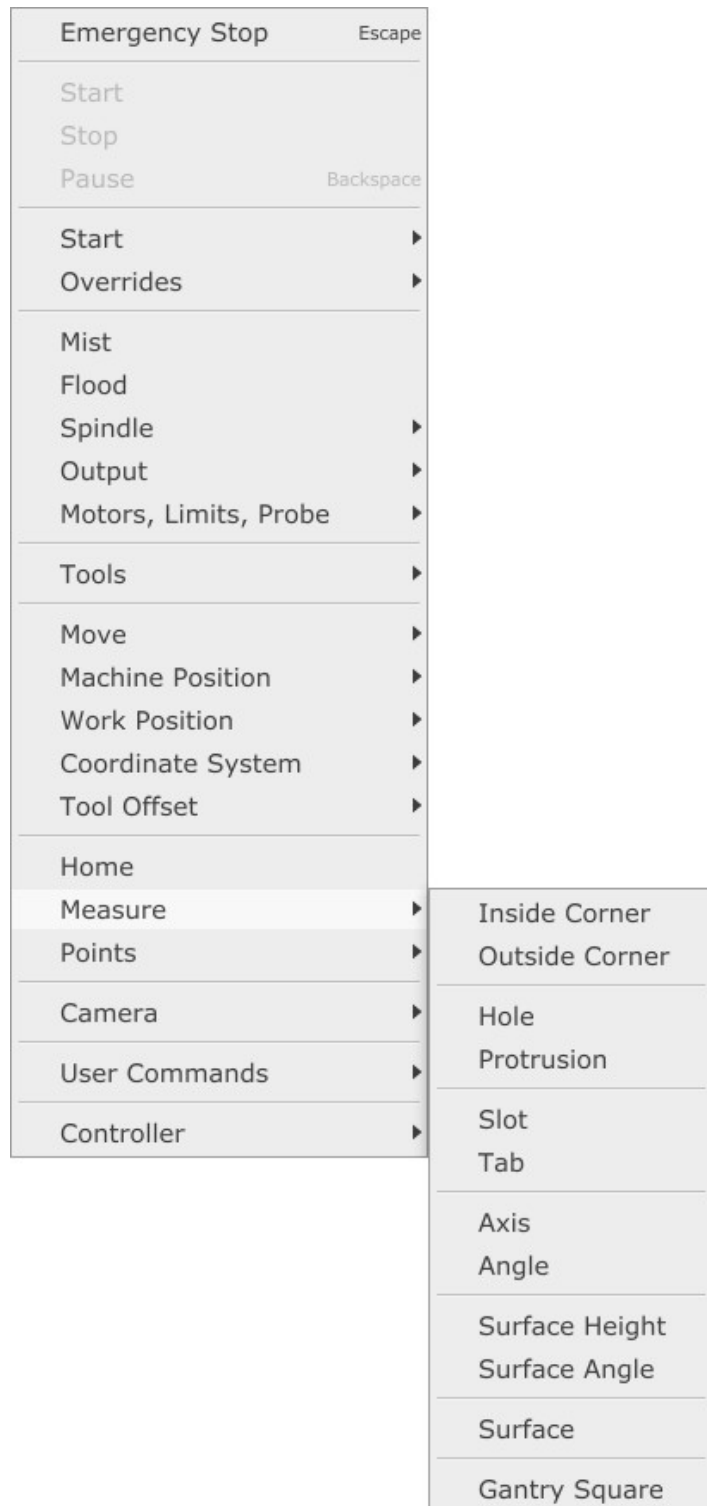

2.7.19.1 Inside Corner

This program feature is script-able. For more info regarding Scripts, please read chapters Scripts(3.0) and Settings/Scripts(2.9.8.10)

This method is useful when user would like to measure the inner point of an inside corner geometry. Displayed illustrations will help user select correct measurement option.

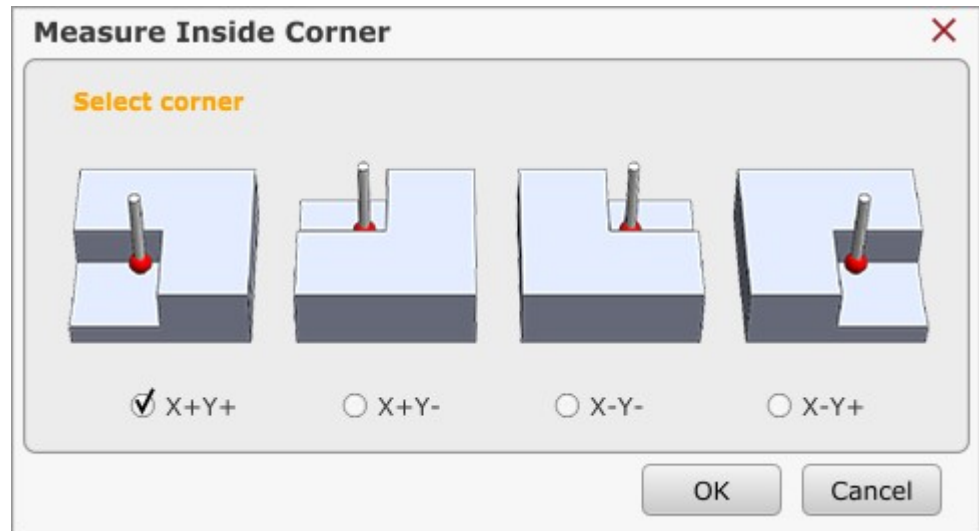

2.7.19.1.1 X+ Y+

- Measurement starts at current position in X+ direction. Once probe is tripped, machine will retract in X- direction to start position.
- Machine will move in Y+ direction. Once probe is tripped, machine will retract in Y- direction to start position.
- Machine Z axis will move to *Safe Height* and then travel to measured corner position.

2.7.19.1.2 X+ Y-

- Measurement starts at current position in X+ direction. Once probe is tripped, machine will retract in X- direction to start position.
- Machine will move in Y- direction. Once probe is tripped, machine will retract in Y+ direction to start position.
- Machine Z axis will move to *Safe Height* and then travel to measured corner position.

2.7.19.1.3 X- Y-

- Measurement starts at current position in X- direction. Once probe is tripped, machine will retract in X+ direction to start position.
- Machine will move in Y- direction. Once probe is tripped, machine will retract in Y+ direction to start position.
- Machine Z axis will move to *Safe Height* and then travel to measured corner position.

2.7.19.1.4 X- Y+

- Measurement starts at current position in X- direction. Once probe is tripped, machine will retract in X+ direction to start position.
- Machine will move in Y+ direction. Once probe is tripped, machine will retract in Y- direction to start position.
- Machine Z axis will move to *Safe Height* and then travel to measured corner position.

2.7.19.2 Outside Corner

This program feature is script-able. For more info regarding Scripts, please read chapters *Scripts(3.0)* and *Settings/Scripts(2.9.8.10)*

This method is useful when user would like to measure the inner point of an outside corner geometry. Displayed illustrations will help user select correct measurement option.

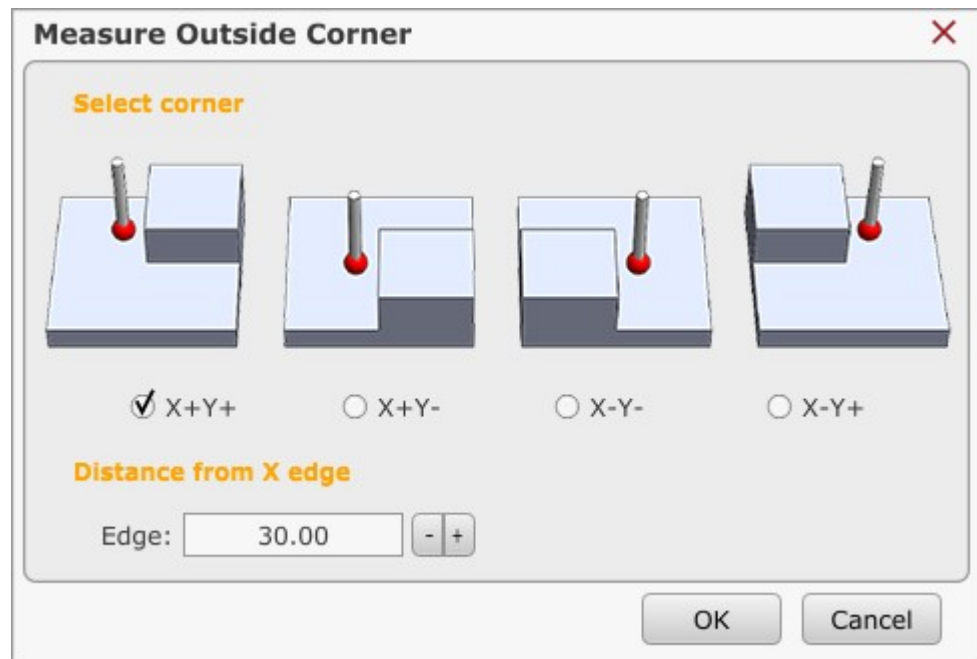

2.7.19.2.1 Distance from X edge

This parameter is distance from the first X axis edge to next Y axis measurement point.

2.7.19.2.2 X+ Y+

- Measurement starts in X+ direction at current machine position. Once probe is tripped, machine will retract in X- direction back to start position.
- Machine Z axis will move to *Safe Height*
- Machine will move along X+ axis for distance of first measured point + *Distance from X edge* value
- Machine will move along Y- axis for same distance as for X axis (at *Safe Height*)
- Z axis will travel from *Safe Height* back to start Z height
- Machine will move in Y+ direction. Once probe is tripped, machine will retract in Y- direction to start Y axis position.
- Machine Z axis will move to *Safe Height* and then travel to measured corner initial position.

2.7.19.2.3 X+ Y-

- Measurement starts in X+ direction at current machine position. Once probe is tripped, machine will retract in X- direction back to start position.
- Machine Z axis will move to *Safe Height*
- Machine will move along X+ axis for distance of first measured point + *Distance from X edge* value
- Machine will move along Y+ axis for same distance as for X axis (at *Safe Height*)
- Z axis will travel from *Safe Height* back to start Z height
- Machine will move in Y- direction. Once probe is tripped, machine will retract in Y+ direction to start Y axis position.
- Machine Z axis will move to *Safe Height* and then travel to measured corner initial position.

2.7.19.2.4 X- Y-

- Measurement starts in X- direction at current machine position. Once probe is tripped, machine will retract in X+ direction back to start position. Machine Z axis will move to *Safe Height*
- Machine will move along X- axis for distance of first measured point + *Distance from X edge* value
- Machine will move along Y+ axis for same distance as for X axis (at *Safe Height*)
- Z axis will travel from *Safe Height* back to start Z height
- Machine will move in Y- direction. Once probe is tripped, machine will retract in Y+ direction to start Y axis position.
- Machine Z axis will move to *Safe Height* and then travel to measured corner initial position.

2.7.19.2.5 X- Y+

- Measurement starts in X- direction at current machine position. Once probe is tripped, machine will retract in X+ direction back to start position.
- Machine Z axis will move to *Safe Height*
- Machine will move along X- axis for distance of first measured point + *Distance from X edge* value
- Machine will move along Y- axis for same distance as for X axis (at *Safe Height*)
- Z axis will travel from *Safe Height* back to start Z height
- Machine will move in Y+ direction. Once probe is tripped, machine will retract in Y- direction to start Y axis position.
- Machine Z axis will move to *Safe Height* and then travel to measured corner initial position.

2.7.19.3 Hole

This program feature is script-able. For more info regarding Scripts, please read chapters Scripts(3.0) and Settings/Scripts(2.9.8.10)

This method is useful when user would like to measure the centre point of symmetrical hole geometry.

- Position machine to approximate centre of a hole
- Measurement starts in X+ direction at current machine position. Once probe is tripped, machine will retract in X- direction back to start position.
- Measurement continues in X- direction. Once probe is tripped, machine will retract in X+ direction back to start position.
- Measurement continues in Y+ direction. Once probe is tripped, machine will retract in Y- direction back to start position.
- Measurement continues in Y- direction. Once probe is tripped, machine will retract in Y+ direction back to start position.
- Machine will move to measured centre point of hole

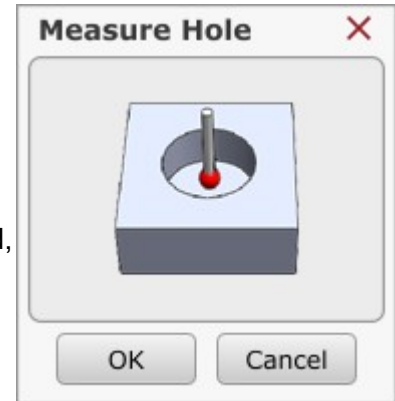

2.7.19.4 Protrusion

This program feature is script-able. For more info regarding Scripts, please read chapters Scripts(3.0) and Settings/Scripts(2.9.8.10)

This method is useful when user would like to measure the centre point of symmetrical protrusion geometry.

2.7.19.4.1 Protrusion size

This parameter is diameter value of the measured geometry.

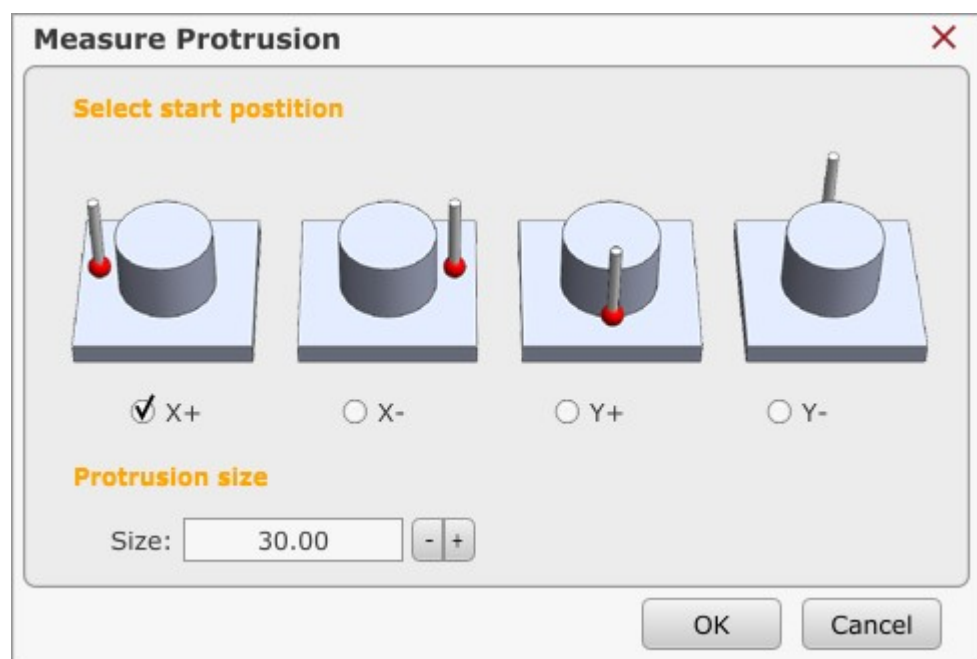

2.7.19.4.2 X+

- Measurement starts in X+ direction at current machine position. Once probe is tripped, machine will retract in X- direction back to start position.
- Machine Z axis will move to *Safe Height*
- Machine will travel in X+ direction at *Safe Height* for distance of first measured X point and *Protrusion Size* distance value.
- Z axis will travel from *Safe Height* back to start Z height
- Machine will move in X- direction. Once probe is tripped, machine will retract in X+ direction to X axis start position.
- Machine Z axis will move to *Safe Height*
- Machine will move to measured centre X axis point and then in Y+ direction for *Protrusion size* distance value.
- Z axis will travel from *Safe Height* back to start Z height
- Machine will move in Y- direction. Once probe is tripped, machine will retract in Y+ direction to Y axis start position.
- Machine Z axis will move to *Safe Height*
- Machine will move travel in Y- direction for distance of first measured Y point and *Protrusion Size* distance value.
- Z axis will travel from *Safe Height* back to start Z height
- Machine will move in Y+ direction. Once probe is tripped, machine will retract in Y- direction to Y axis start position.
- Machine Z axis will move to *Safe Height* and then travel to measured centre position of protrusion.

2.7.19.4.3 X-

- Measurement starts in X- direction at current machine position. Once probe is tripped, machine will retract in X+ direction back to start position.
- Machine Z axis will move to *Safe Height*
- Machine will travel in X- direction at *Safe Height* for distance of first measured X point and *Protrusion Size* distance value.
- Z axis will travel from *Safe Height* back to start Z height
- Machine will move in X+ direction. Once probe is tripped, machine will retract in X- direction to X axis start position.
- Machine Z axis will move to *Safe Height*
- Machine will move to measured centre X axis point and then in Y- direction for *Protrusion size* distance value.
- Z axis will travel from *Safe Height* back to start Z height
- Machine will move in Y+ direction. Once probe is tripped, machine will retract in Y- direction to Y axis start position.
- Machine Z axis will move to *Safe Height*
- Machine will move travel in Y+ direction for distance of first measured Y point and *Protrusion Size* distance value.
- Z axis will travel from *Safe Height* back to start Z height
- Machine will move in Y- direction. Once probe is tripped, machine will retract in Y+ direction to Y axis start position.
- Machine Z axis will move to *Safe Height* and then travel to measured centre position of protrusion.

2.7.19.4.4 Y+

- Measurement starts in Y+ direction at current machine position. Once probe is tripped, machine will retract in Y- direction back to start position.
- Machine Z axis will move to *Safe Height*
- Machine will travel in Y+ direction at *Safe Height* for distance of first measured Y point and *Protrusion Size* distance value.
- Z axis will travel from *Safe Height* back to start Z height
- Machine will move in Y- direction. Once probe is tripped, machine will retract in Y+ direction to Y axis start position.
- Machine Z axis will move to *Safe Height*
- Machine will move to measured centre Y axis point and then in X+ direction for *Protrusion size* distance value.
- Z axis will travel from *Safe Height* back to start Z height
- Machine will move in X- direction. Once probe is tripped, machine will retract in X+ direction to Y axis start position.
- Machine Z axis will move to *Safe Height*
- Machine will move travel in X- direction for distance of first measured X point and *Protrusion Size* distance value.
- Z axis will travel from *Safe Height* back to start Z height
- Machine will move in X+ direction. Once probe is tripped, machine will retract in X- direction to X axis start position.
- Machine Z axis will move to *Safe Height* and then travel to measured centre position of protrusion.

2.7.19.4.5 Y-

- Measurement starts in Y- direction at current machine position. Once probe is tripped, machine will retract in Y+ direction back to start position.
- Machine Z axis will move to *Safe Height*
- Machine will travel in Y- direction at *Safe Height* for distance of first measured Y point and *Protrusion Size* distance value.
- Z axis will travel from *Safe Height* back to start Z height
- Machine will move in Y+ direction. Once probe is tripped, machine will retract in Y- direction to Y axis start position.
- Machine Z axis will move to *Safe Height*
- Machine will move to measured centre Y axis point and then in X- direction for *Protrusion size* distance value.
- Z axis will travel from *Safe Height* back to start Z height
- Machine will move in X+ direction. Once probe is tripped, machine will retract in X- direction to X axis start position.
- Machine Z axis will move to *Safe Height*
- Machine will move travel in X+ direction for distance of first measured X point and *Protrusion Size* distance value.
- Z axis will travel from *Safe Height* back to start Z height
- Machine will move in X- direction. Once probe is tripped, machine will retract in X+ direction to X axis start position.
- Machine Z axis will move to *Safe Height* and then travel to measured centre position of protrusion.

2.7.19.5 Slot

This program feature is script-able. For more info regarding Scripts, please read chapters Scripts(3.0) and Settings/Scripts(2.9.8.10)

This method is useful when user would like to measure the centre point of slot geometry.

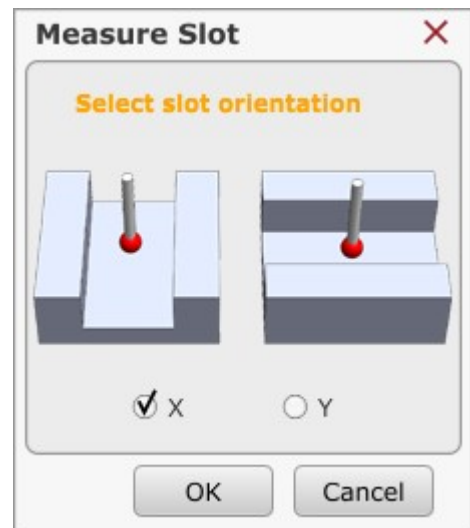

2.7.19.5.1 X

- Measurement starts in X+ direction at current machine position. Once probe is tripped, machine will retract in X- direction back to start position.
- Machine will move in X- direction. Once probe is tripped, machine will retract in X+ direction to X axis start position
- Machine will travel to measured centre position of slot.

2.7.19.5.2 Y

- Measurement starts in Y+ direction at current machine position. Once probe is tripped, machine will retract in Y- direction back to start position.
- Machine will move in Y- direction. Once probe is tripped, machine will retract in Y+ direction to Y axis start position
- Machine will travel to measured centre position of slot.

2.7.19.6 Tab

This program feature is script-able. For more info regarding Scripts, please read chapters *Scripts(3.0)* and *Settings/Scripts(2.9.8.10)*

This method is useful when user would like to measure the centre point of tab geometry.

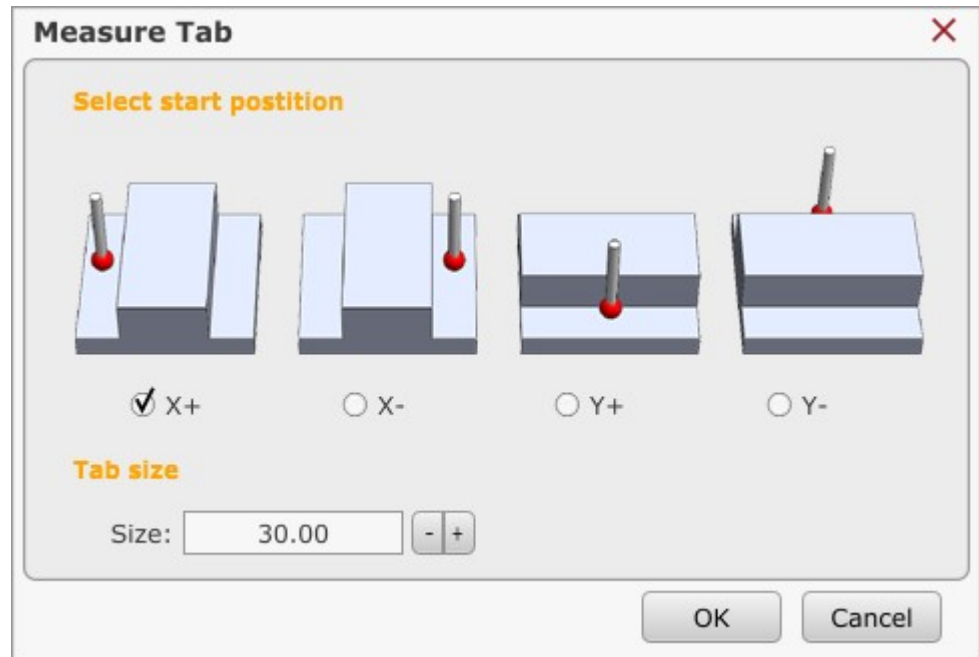

2.7.19.6.1 X+

- Measurement starts in X+ direction at current machine position. Once probe is tripped, machine will retract in X- direction back to start position.
- Machine Z axis will move to *Safe Height*
- Machine will travel in X+ direction at *Safe Height* for distance of first measured X point and *Tab Size* distance value.
- Z axis will travel from *Safe Height* back to start Z height
- Machine will move in X- direction. Once probe is tripped, machine will retract in X+ direction to X axis start position.
- Machine Z axis will move to *Safe Height*
- Machine will move to measured centre of tab

2.7.19.6.2 X-

- Measurement starts in X- direction at current machine position. Once probe is tripped, machine will retract in X+ direction back to start position.
- Machine Z axis will move to *Safe Height*
- Machine will travel in X- direction at *Safe Height* for distance of first measured X point and *Tab Size* distance value.
- Z axis will travel from *Safe Height* back to start Z height
- Machine will move in X+ direction. Once probe is tripped, machine will retract in X- direction to X axis start position.
- Machine Z axis will move to *Safe Height*
- Machine will move to measured centre of tab

2.7.19.6.3 Y+

- Measurement starts in Y+ direction at current machine position. Once probe is tripped, machine will retract in Y- direction back to start position.
- Machine Z axis will move to *Safe Height*
- Machine will travel in Y+ direction at *Safe Height* for distance of first measured Y point and *Tab Size* distance value.
- Z axis will travel from *Safe Height* back to start Z height
- Machine will move in Y- direction. Once probe is tripped, machine will retract in Y+ direction to Y axis start position.
- Machine Z axis will move to *Safe Height*
- Machine will move to measured centre of tab

2.7.19.6.4 Y-

- Measurement starts in Y- direction at current machine position. Once probe is tripped, machine will retract in Y+ direction back to start position.
- Machine Z axis will move to *Safe Height*
- Machine will travel in Y- direction at *Safe Height* for distance of first measured Y point and *Tab Size* distance value.
- Z axis will travel from *Safe Height* back to start Z height
- Machine will move in Y+ direction. Once probe is tripped, machine will retract in Y- direction to Y axis start position.
- Machine Z axis will move to *Safe Height*
- Machine will move to measured centre of tab

2.7.19.7 Axis

This program feature is script-able. For more info regarding Scripts, please read chapters *Scripts(3.0)* and *Settings/Scripts(2.9.8.10)*

This method is useful when user would like to measure the edge geometry and e.g. set zero work position.

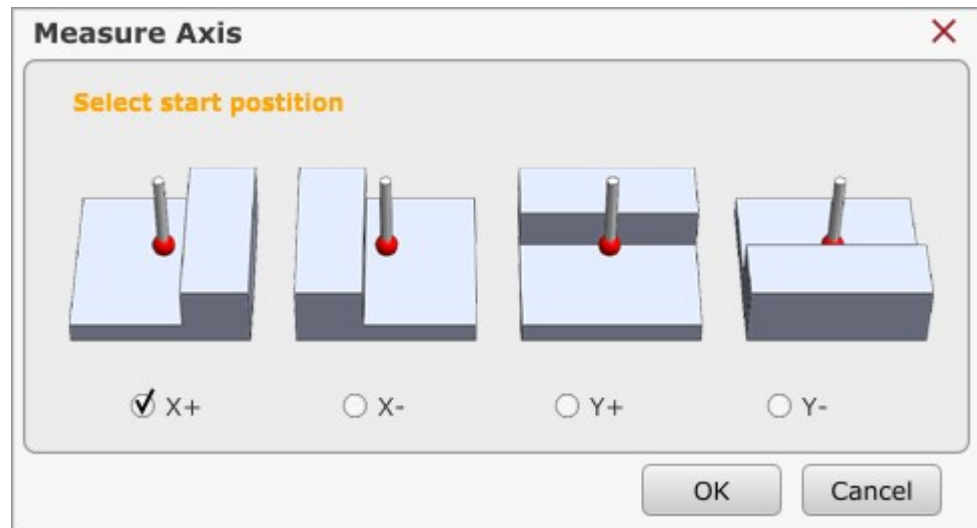

2.7.19.7.1 X+

- Measurement starts in X+ direction at current machine position. Once probe is tripped, machine will retract in X- direction back to start position.
- Machine Z axis will move to *Safe Height*
- Machine will travel in X+ direction at *Safe Height* to measured edge position.

2.7.19.7.2 X-

- Measurement starts in X- direction at current machine position. Once probe is tripped, machine will retract in X+ direction back to start position.
- Machine Z axis will move to *Safe Height*
- Machine will travel in X- direction at *Safe Height* to measured edge position.

2.7.19.7.3 Y+

- Measurement starts in Y+ direction at current machine position. Once probe is tripped, machine will retract in Y- direction back to start position.
- Machine Z axis will move to *Safe Height*
- Machine will travel in Y+ direction at *Safe Height* to measured edge position.

2.7.19.7.4 Y-

- Measurement starts in Y- direction at current machine position. Once probe is tripped, machine will retract in Y+ direction back to start position.
- Machine Z axis will move to *Safe Height*
- Machine will travel in Y- direction at *Safe Height* to measured edge position.

2.7.19.8 Angle

This program feature is script-able. For more info regarding Scripts, please read chapters *Scripts(3.0)* and *Settings/Scripts(2.9.8.10)*

This method is useful when user would like to measure the angle of edge geometry.

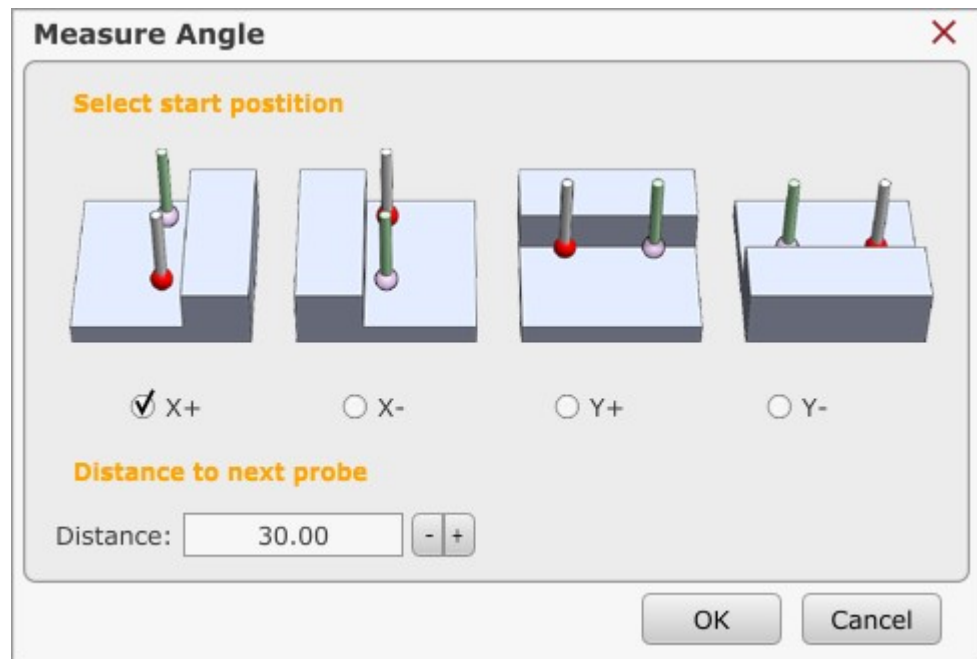

2.7.19.8.1 X+

- Measurement starts in X+ direction at current machine position. Once probe is tripped, machine will retract in X- direction back to start position and move in the Y+ direction for *Distance to next probe* distance value
- Machine will move in X+ direction at current machine position. Once probe is tripped, machine will retract in X- direction back to start position
- Z axis will move to *Safe Height*
- Machine will move to position of first measured point of X axis edge geometry. Print command will display value of measured axis edge position and angle value.

2.7.19.8.2 X-

- Measurement starts in X- direction at current machine position. Once probe is tripped, machine will retract in X+ direction back to start position and move in the Y- direction for *Distance to next probe* distance value
- Machine will move in X- direction at current machine position. Once probe is tripped, machine will retract in X+ direction back to start position
- Z axis will move to *Safe Height*
- Machine will move to position of first measured point of X axis edge geometry. Print command will display value of measured axis edge position and angle value.

2.7.19.8.3 Y+

- Measurement starts in Y+ direction at current machine position. Once probe is tripped, machine will retract in Y- direction back to start position and move in the X+ direction for *Distance to next probe* distance value
- Machine will move in Y+ direction at current machine position. Once probe is tripped, machine will retract in Y- direction back to start position
- Z axis will move to *Safe Height*
- Machine will move to position of first measured point of Y axis edge geometry. Print command will display value of measured axis edge position and angle value.

2.7.19.8.4 Y-

- Measurement starts in Y- direction at current machine position. Once probe is tripped, machine will retract in Y+ direction back to start position and move in the X- direction for *Distance to next probe* distance value
- Machine will move in Y- direction at current machine position. Once probe is tripped, machine will retract in Y+ direction back to start position
- Z axis will move to *Safe Height*
- Machine will move to position of first measured point of Y axis edge geometry. Print command will display value of measured axis edge position and angle value.

2.7.19.9 Surface Height

This program feature is script-able. For more info regarding Scripts, please read chapters *Scripts(3.0)* and *Settings/Scripts(2.9.8.10)*

This method is useful when user would like to measure surface height of workpiece. User can set Z axis zero or Z axis coordinate system zero position values.

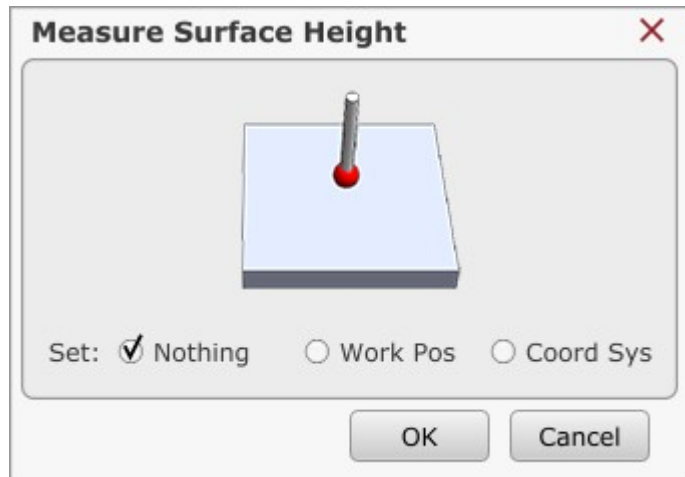

- Measurement starts in Z- direction at current machine position. Once probe is tripped, machine will retract in Z+ direction back to start position. Based on the option selected, software will either do nothing(values will still be printed in the *output* window), set Z axis **work position** zero value or set Z axis zero position value of **coordinate system**.

2.7.19.10 Surface Angle

This program feature is script-able. For more info regarding Scripts, please read chapters Scripts(3.0) and Settings/Scripts(2.9.8.10)

This method is useful when user would like to measure surface angle of workpiece.

With *Distance* parameter you set distance value between three neighbouring measurement points.

- Measurement starts in Z- direction at current machine position. Once probe is tripped, machine will retract in Z+ direction back to start position.
- Machine will move in X+ direction for *Distance* distance value. Machine will move in Z- direction. Once probe is tripped, machine will retract in Z+ direction back to start position.
- Machine will move at angle of 120 degrees to last measurement point. At last measurement position, machine will move in Z- direction. Once probe is tripped, machine will retract in Z+ direction back to start position.

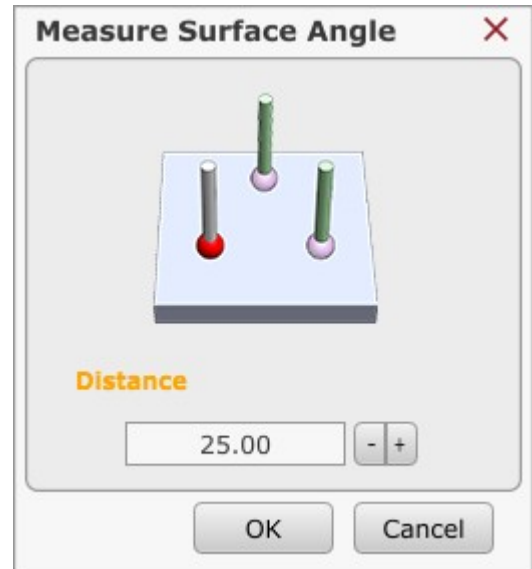

2.7.19.11 Surface

This program feature is script-able. For more info regarding Scripts, please read chapters Scripts(3.0) and Settings/Scripts(2.9.8.10)

This method is useful when user would like to measure surface points. Measurement points are saved and can be used for later use, e.g. Warp, Transformation etc...

2.7.19.11.1 Size

X: Size of X axis measurement area.

Y: Size of Y axis measurement area.

2.7.19.11.2 Step

X: Step distance between two neighbouring measurement points for X axis.

Y: Distance increment between two neighbouring measuring points for Y axis.

2.7.19.11.3 Return Distance

This is distance value for which machine retracts once probe has been tripped.

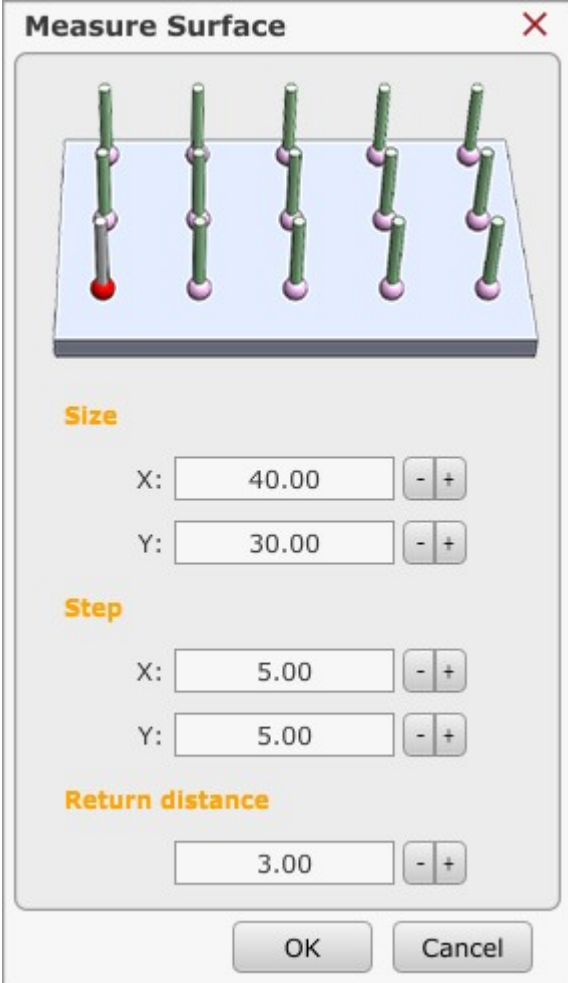

Measure Surface [X]

Size

X: - +

Y: - +

Step

X: - +

Y: - +

Return distance

- +

OK Cancel

2.7.19.12 Gantry Square

Initiates Gantry Square procedure.

2.7.20 Points

User can save, load or export measured points.

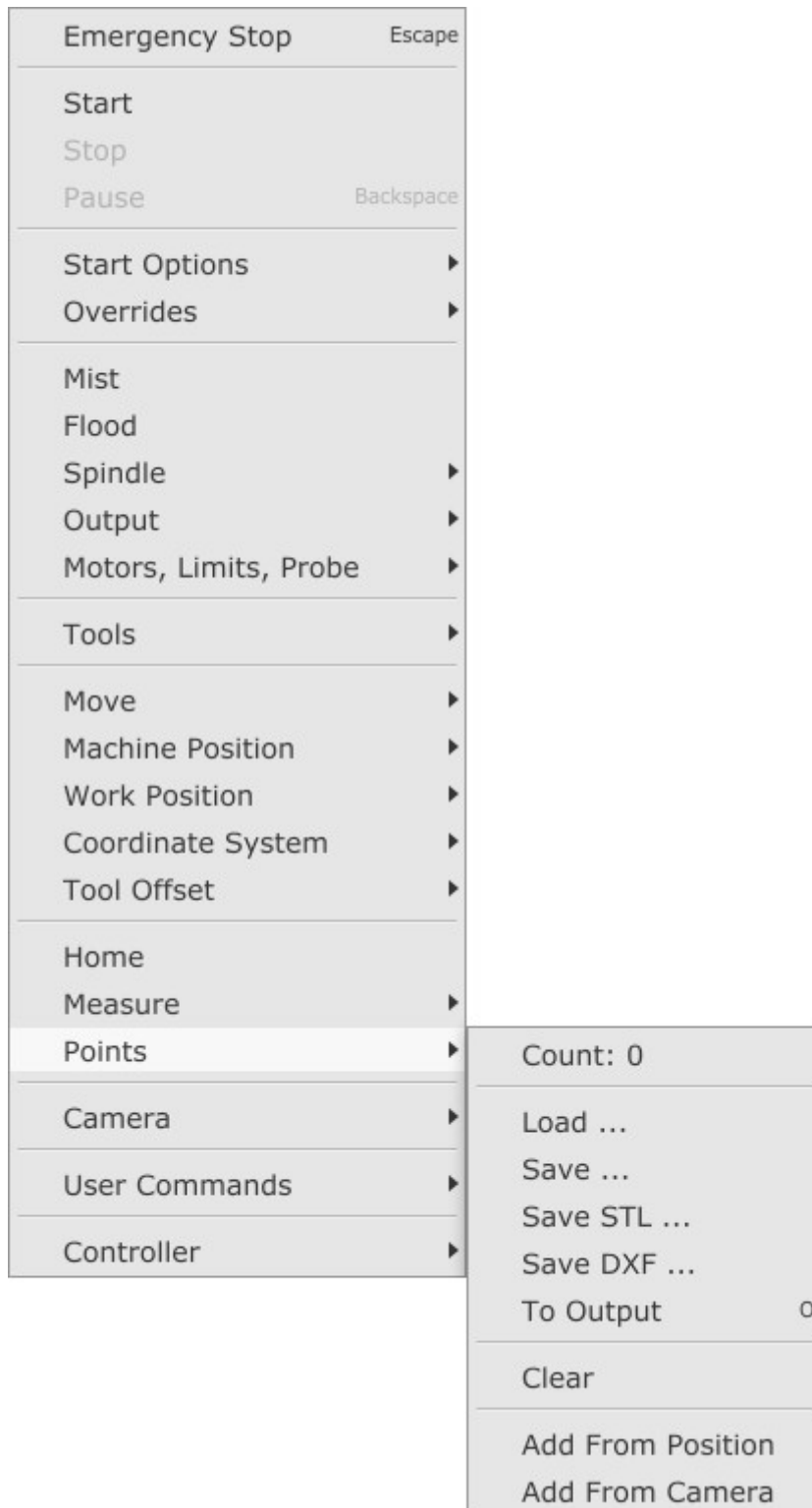

2.7.20.1 Count

Displays current count of measured points.

2.7.20.2 Load

Loads previously saved file of measured points.

2.7.20.3 Save

User can save measured points as file.

2.7.20.4 Save STL

Saves measured points as STL file. Points will be saved as toolpath.

2.7.20.5 Save DXF

Saves measured points as DXL file. Points will be saved as toolpath.

2.7.20.6 To Output

Point coordinates from point count are displayed in the output window.

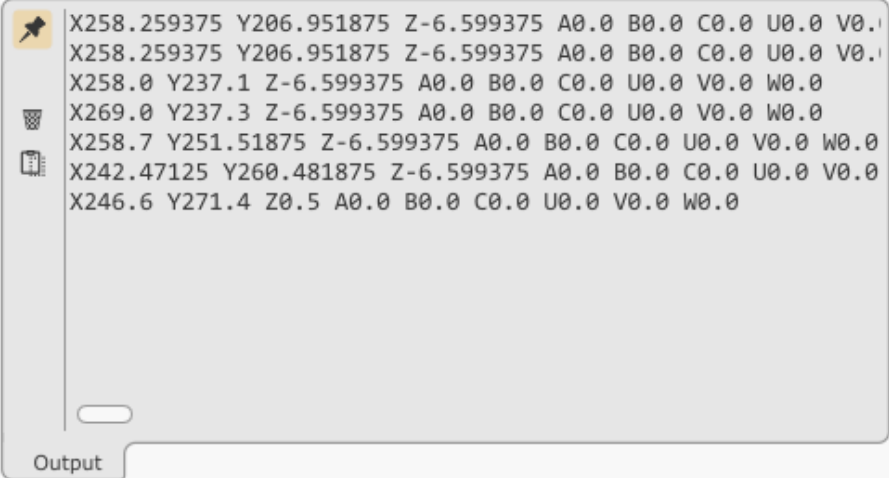

```
X258.259375 Y206.951875 Z-6.599375 A0.0 B0.0 C0.0 U0.0 V0.0 W0.0
X258.259375 Y206.951875 Z-6.599375 A0.0 B0.0 C0.0 U0.0 V0.0 W0.0
X258.0 Y237.1 Z-6.599375 A0.0 B0.0 C0.0 U0.0 V0.0 W0.0
X269.0 Y237.3 Z-6.599375 A0.0 B0.0 C0.0 U0.0 V0.0 W0.0
X258.7 Y251.51875 Z-6.599375 A0.0 B0.0 C0.0 U0.0 V0.0 W0.0
X242.47125 Y260.481875 Z-6.599375 A0.0 B0.0 C0.0 U0.0 V0.0 W0.0
X246.6 Y271.4 Z0.5 A0.0 B0.0 C0.0 U0.0 V0.0 W0.0
```

Output

2.7.20.7 Clear

Clears all currently measured points.

2.7.20.8 Add from Position

Adds new point to current point count. Point coordinate values are current machine position coordinate values.

2.7.20.9 Add from Camera

Adds new point to current point count. Point coordinate values are current machine position coordinate values obtained via Camera view.

2.7.21 Camera

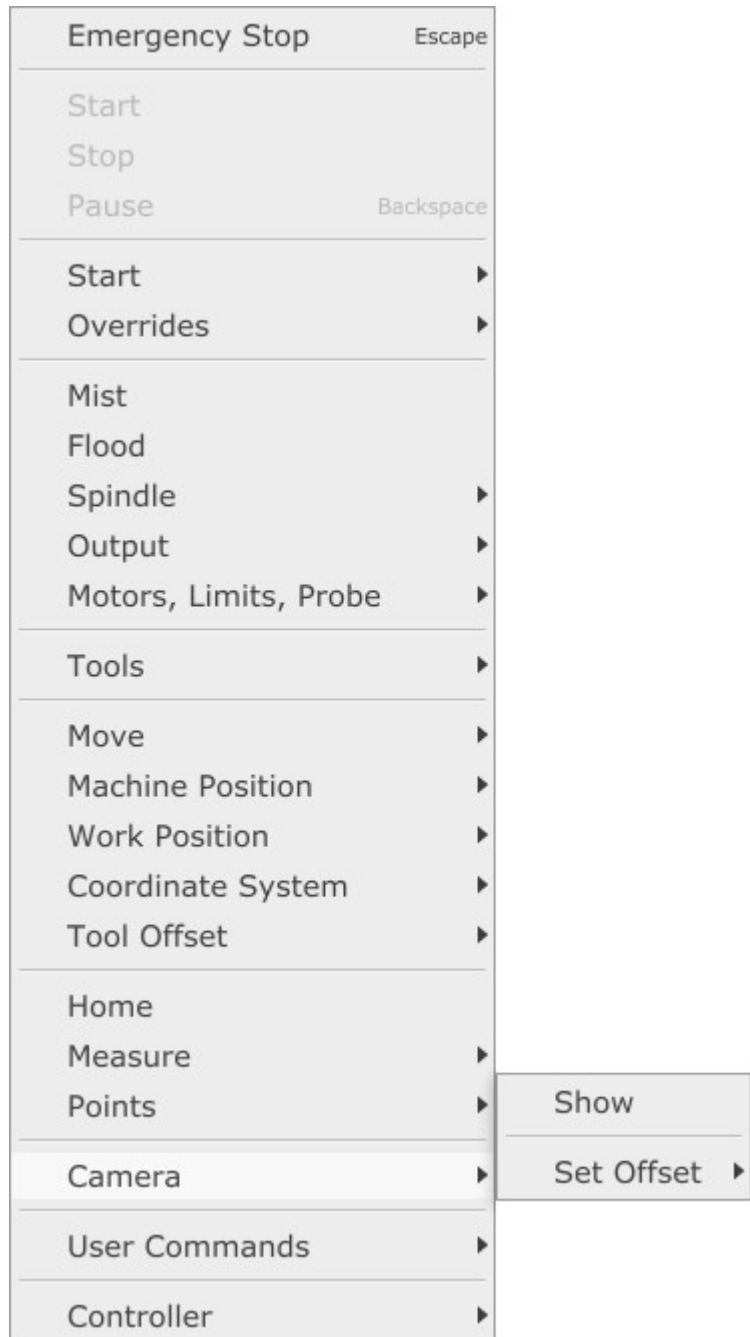

2.7.21.1 Show

Camera Show displays the view visible to a USB web-cam, mounted alongside the spindle, looking down on the workpiece. The large cross-hair marker in the center of the view is used for precise 'targeting' of points on the stock, for measurement or capture purposes.

Available USB web-cams are listed in a drop-down in the center of the panel. Depending on attached hardware, options to use camera filters may also be shown. PlanetCNC TNG software provides adjustment, so the basic web-cam option is selected. Basic web-cam hardware is suitable. It is much less costly to replace in event of failure or damage.

Camera hardware mounted close to spindle experiences much vibration. Robust construction and the ability to mount hardware securely are the most important considerations when choosing web-cam tool sensors. Camera and camera cable might also be source of electrical interference.

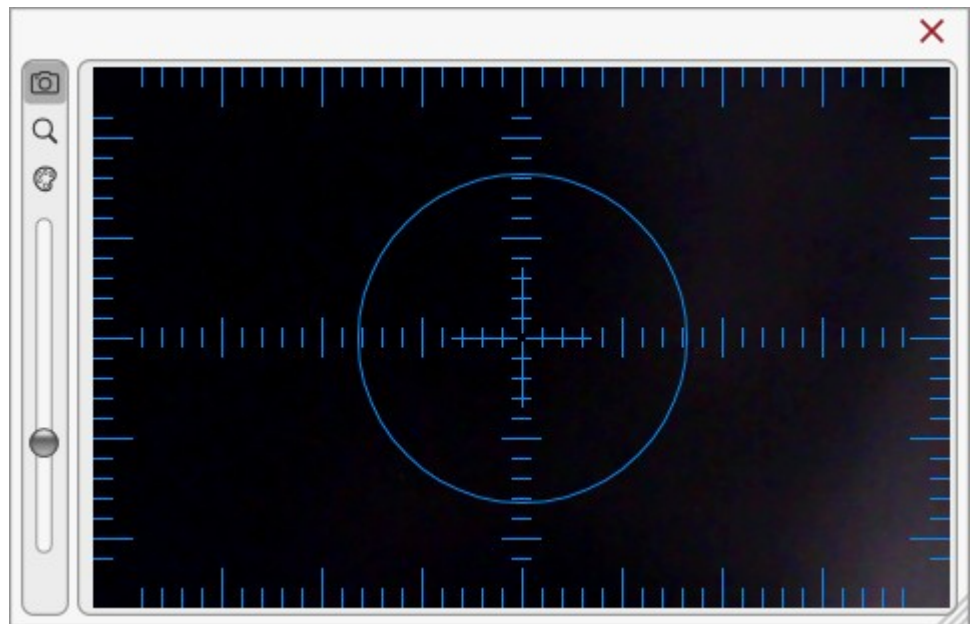

This button opens up a menu displaying all connected and available cameras:

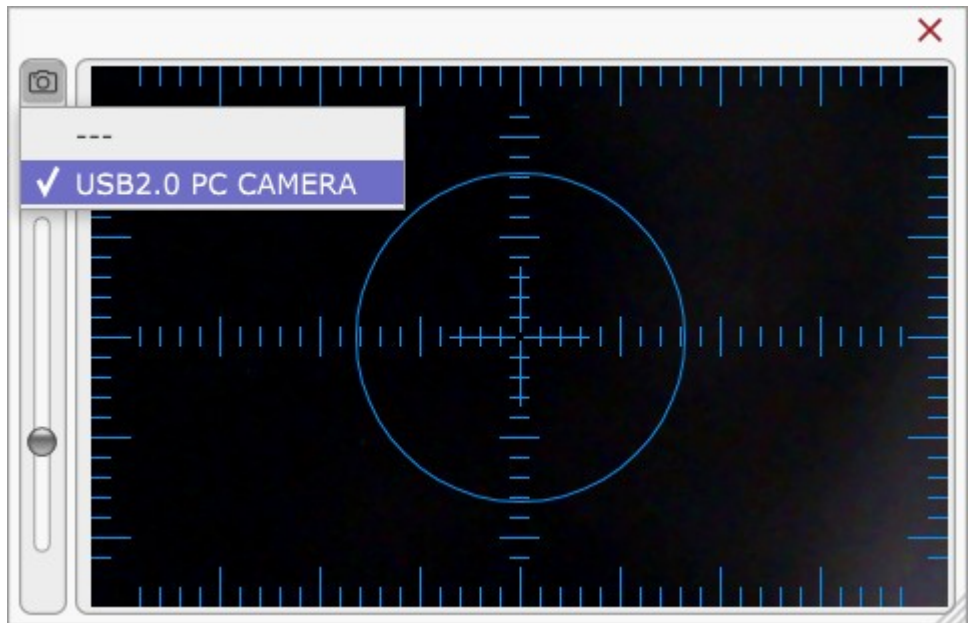
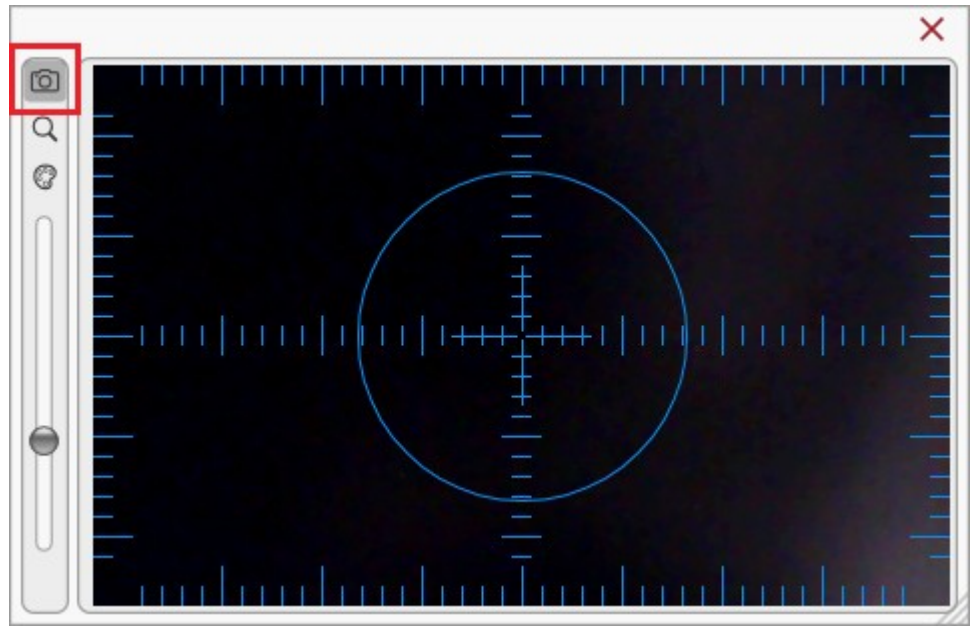

This button opens up a zoom factor menu:

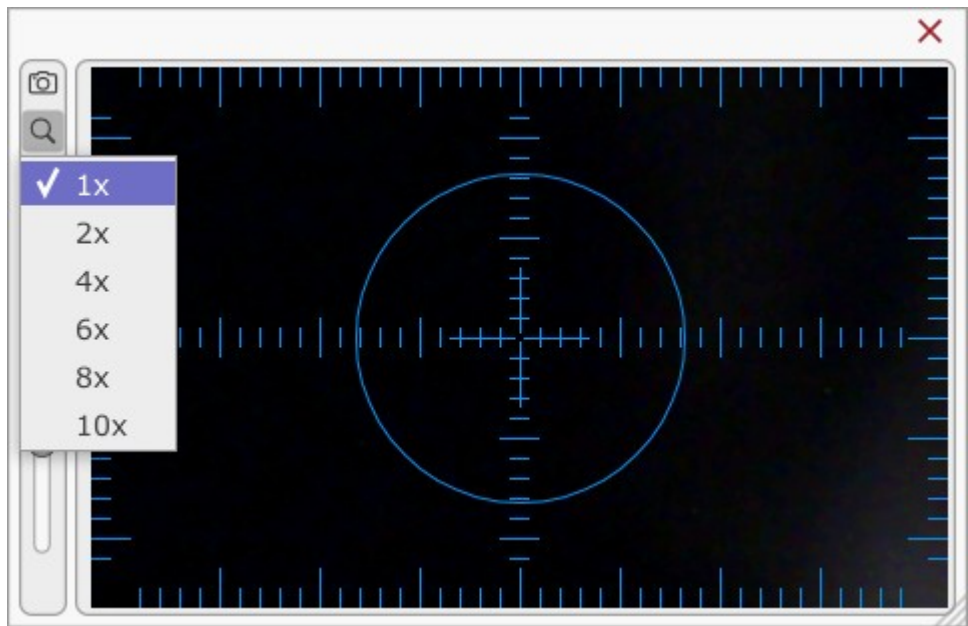
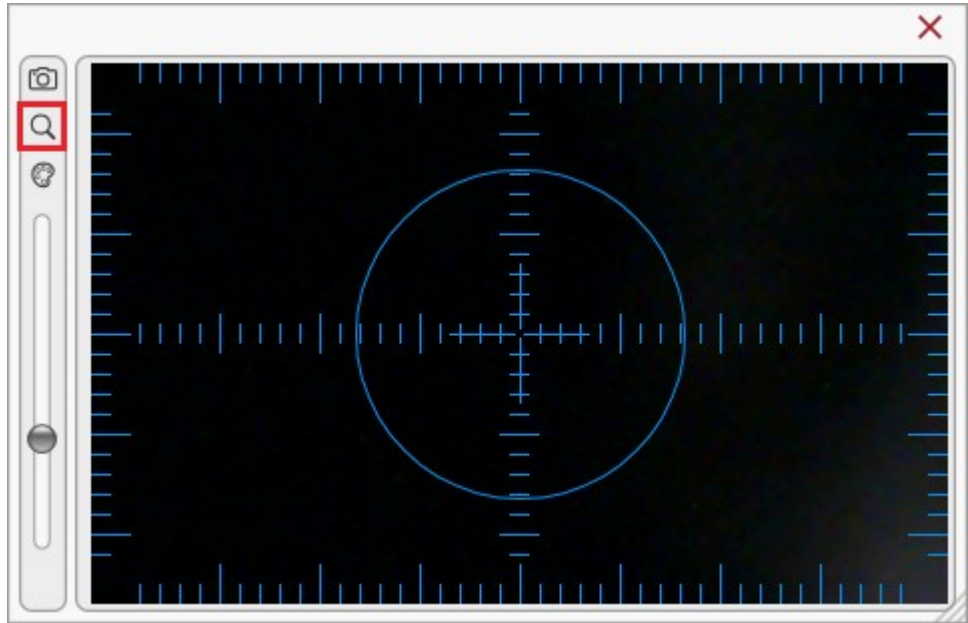

This button opens up a colour palette menu. User

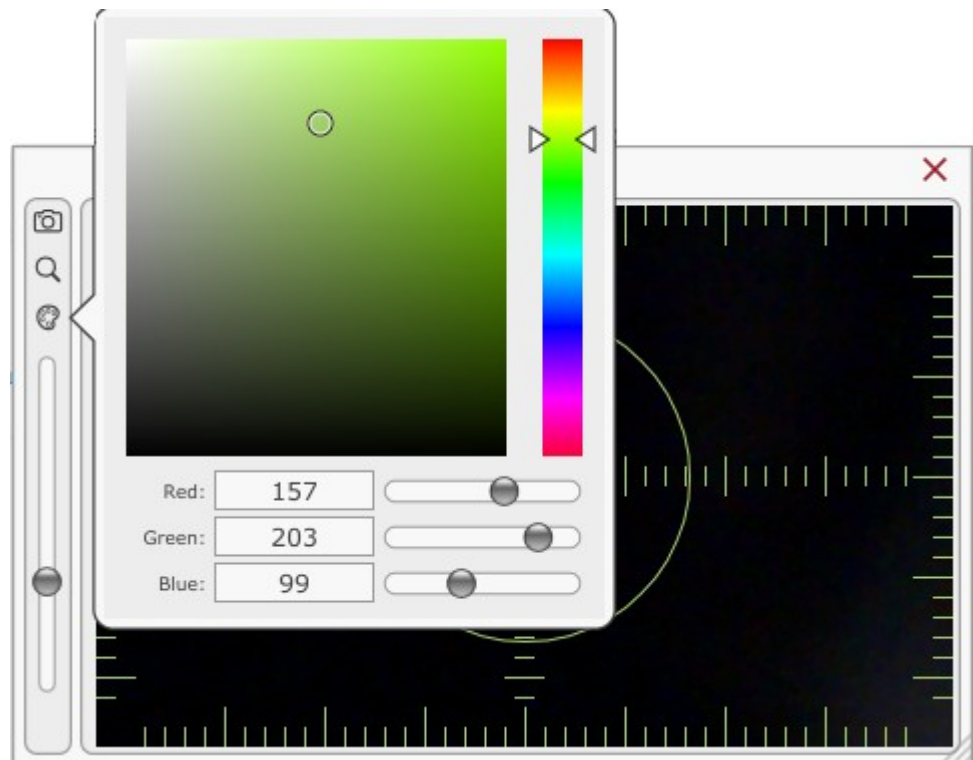
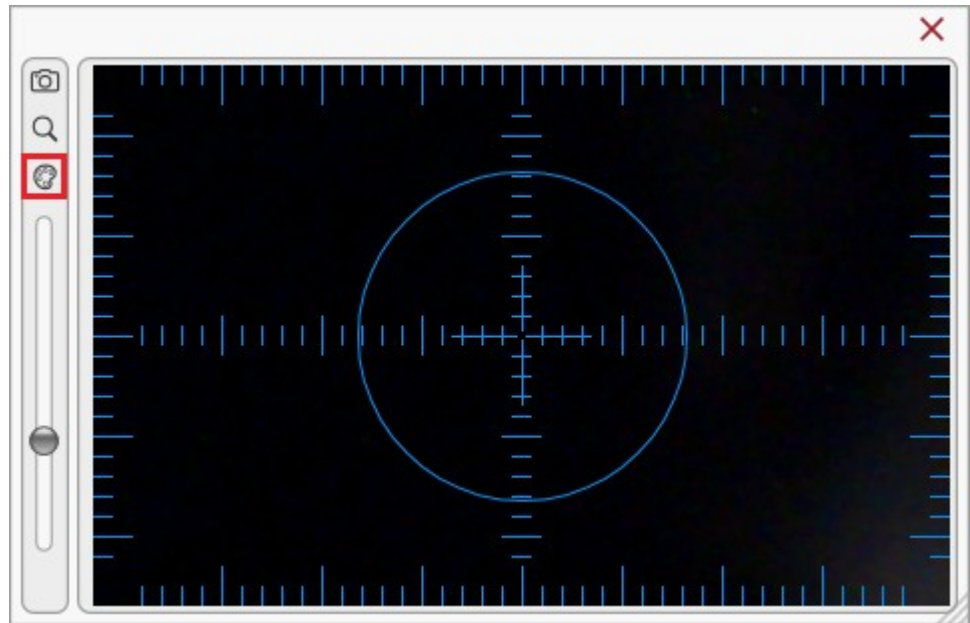

Using the colour settings user can change the colour of crosshair of camera view:

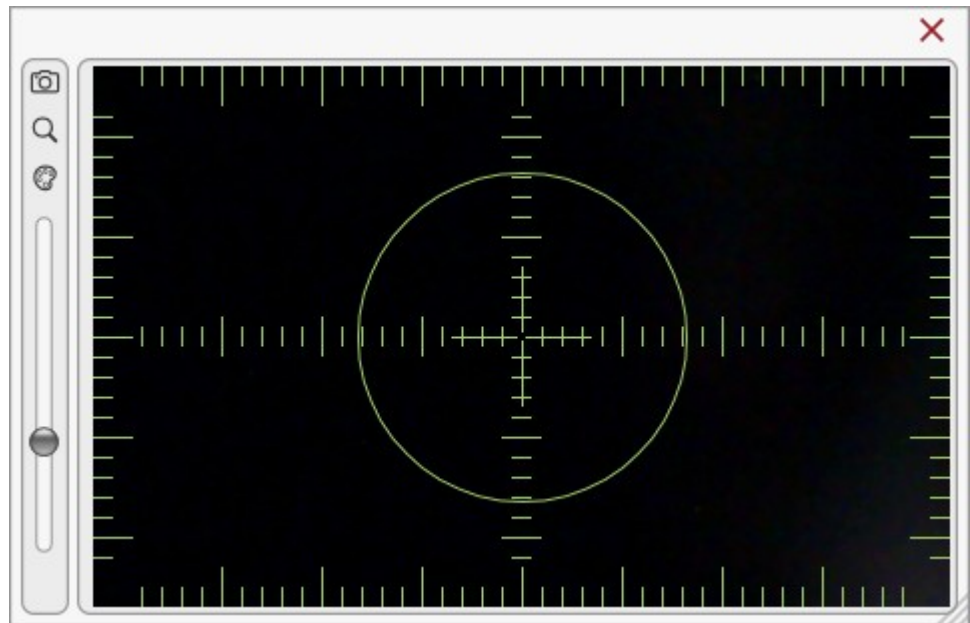

This slider is used for circle diameter adjustment:

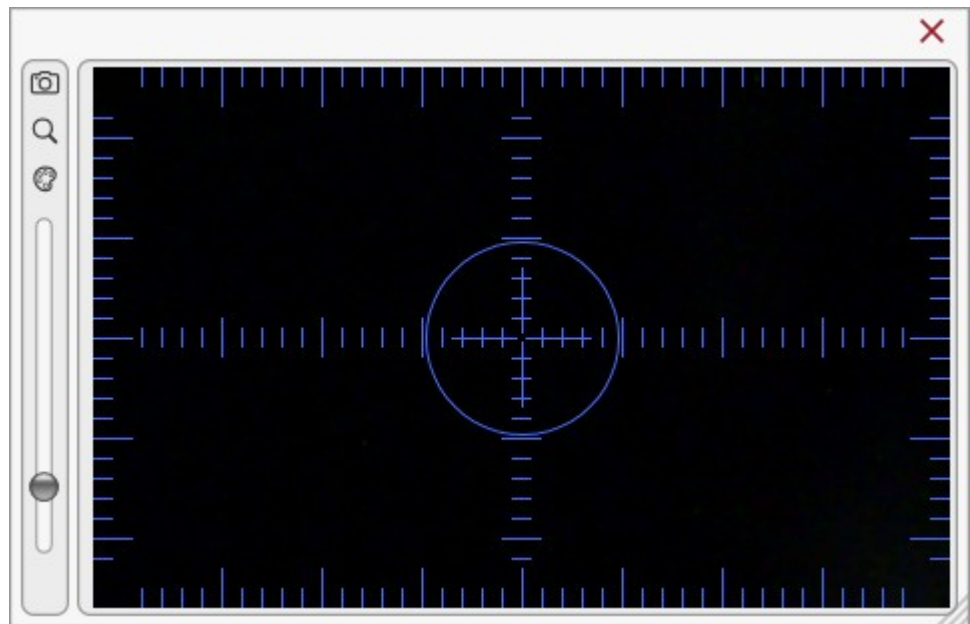
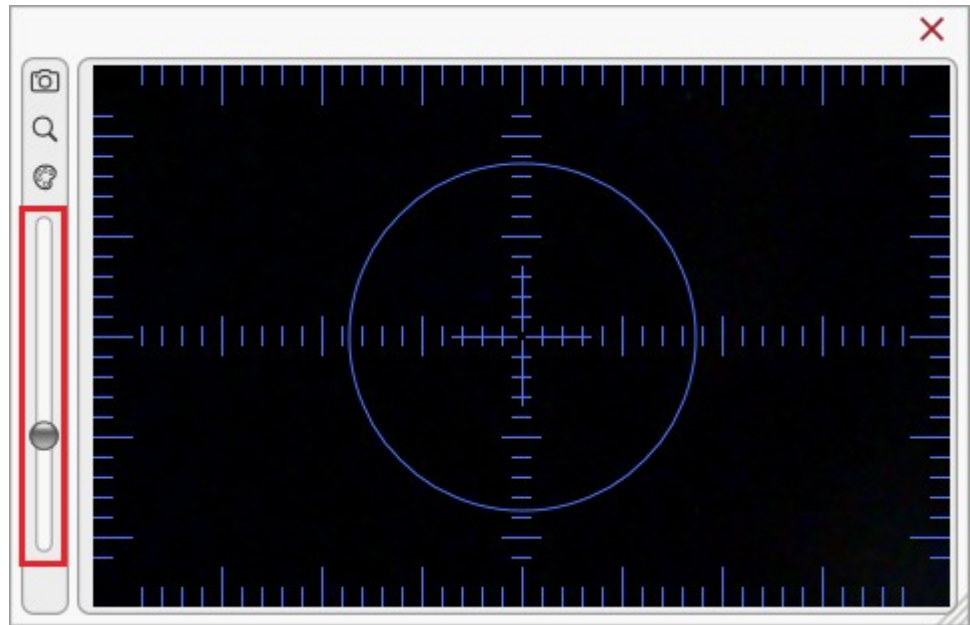

Set Offset

Camera Offset is set here.

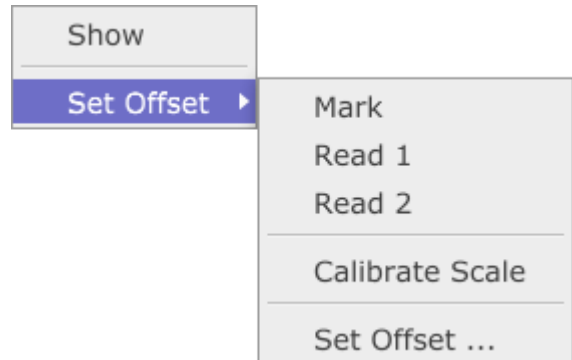

2.7.21.1.1 Mark

Marks camera reference point on machine table which will be used for setting camera offset.

2.7.21.1.2 Read 1

Saves camera reference point position coordinates (X,Y,Z) captured at the lowest Z axis height possible, using camera view. Saved coordinates refer to *Point 1* of *Set Offset* dialog.

2.7.21.1.3 Read 2

Saves camera reference point coordinates (X,Y,Z) captured at the highest Z axis height possible using, camera view. Saved coordinates refer to *Point 2* of *Set Offset* dialog.

2.7.21.1.4 Calibrate Scale

Calibrates camera viewfinder scale/grid for measuring purposes.

2.7.21.1.5 Set Offset

Opens dialog with current *Point 1* and *Point 2* values already populated (if *Read 1* and *Read 2* actions were performed prior). Click OK to set *Camera Offset*.

Camera Offset [X]

Point 1:

X: - +

Y: - +

Z: - +

Point 2:

X: - +

Y: - +

Z: - +

Scale Calibration Distance:

mm - +

OK Cancel

How to set Camera two point offset:

1. Open camera window with *Machine/Camera/Show...*
2. Mark camera reference point on machine table. You can use marker, small drill or tool, ... Whatever you find useful.
3. Position tool exactly over this reference point and click: "Machine/Camera/Set Offset/Mark"
4. Move machine and locate reference point with camera view. Use lowest Z level possible.
5. When reference point is in centre of camera cross-hair marker click: "Machine/Camera/Set Offset/Read 1"
6. Now move Z to highest possible level where marker is still visible on camera view and center it.
7. When camera reference point is in centre of camera cross-hair marker click: "Machine/Camera/Set Offset/Read 2"
8. To set camera offset click: *Machine/Camera/Set Offset* → OK

2.7.22 User Commands

User can write and configure his own programs which are available through *User Commands* sub-menu.

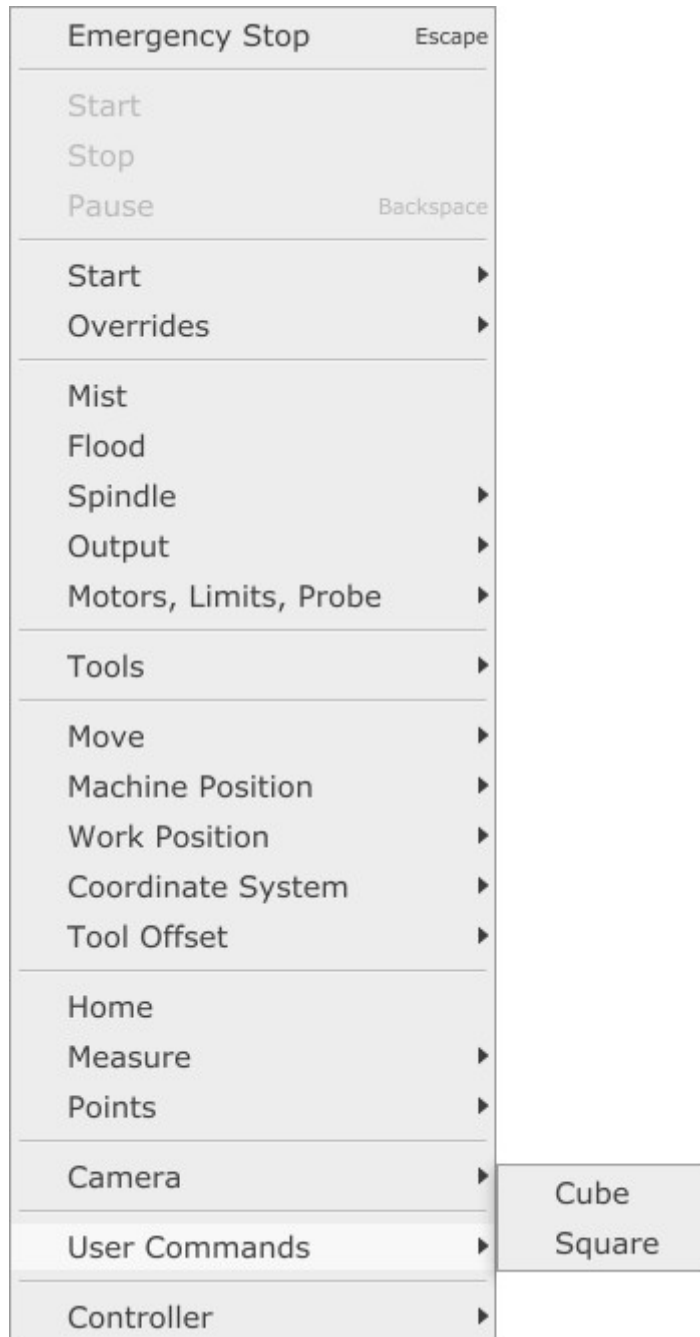

User command programs should be located in user profile folder in *UserCmd* folder.

2.7.23 Controller

Emergency Stop	Escape
Start	
Stop	
Pause	Backspace
Start	▶
Overrides	▶
Mist	
Flood	
Spindle	▶
Output	▶
Motors, Limits, Probe	▶
Tools	▶
Move	▶
Machine Position	▶
Work Position	▶
Coordinate System	▶
Tool Offset	▶
Home	
Measure	▶
Points	▶
Camera	▶
User Commands	▶
Controller	▶

Reconnect
Reset
Firmware Update
Advanced ▶

2.7.23.1 Reconnect

Reconnects communication between controller and software. This comes handy when communication is terminated due to e.g. EM interference.

2.7.23.2 Reset

Resets controller.

2.7.23.3 Firmware Update

Updates controller firmware with version embedded in software. It is not possible to destroy or damage controller with firmware update. If firmware update fails it is always possible to update it again.

2.7.23.4 Advanced

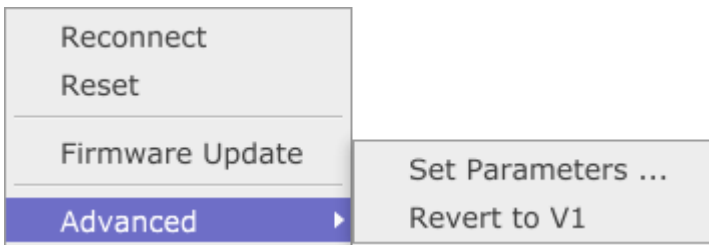

2.7.23.4.1 Controller Parameters

DHCP:

DHCP status of controller

IP:

IP address of controller

Mask:

Mask of controller

Port:

MAC:

MAC address of controller

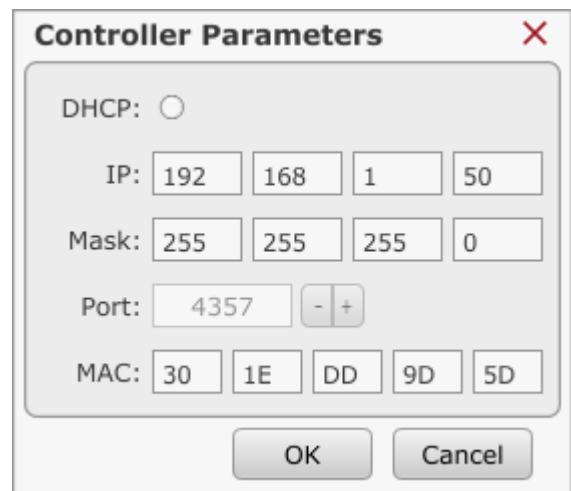

2.7.23.4.2 Revert to V1

Controller can be used with both motion software's from PlanetCNC, *PlanetCNC TNG* software and *CNC USB controller* software.

Controller's firmware needs to be updated with software version that will be used with: PlanetCNC TNG software or CNC USB controller software.

Controller updated with TNG firmware cannot be used with CNC USB sw and controller updated with CNC USB sw firmware cannot be used with TNG software.

If user wants to use controller with CNC USB software once controllers firmware is updated with TNG software, *Revert to V1* reverts controller firmware so that it can be used with CNC USB software.

2.8 Help

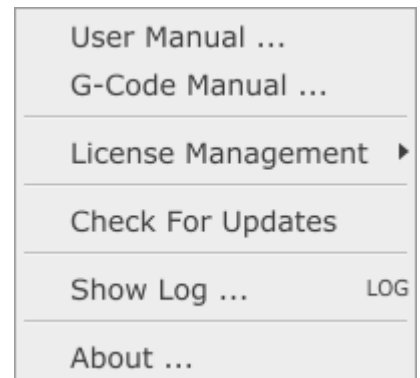

2.8.1 User Manual...

Opens PlanetCNC user manual file.

2.8.2 G-code Manual...

Opens PlanetCNC g-code reference file.

2.8.3 License management

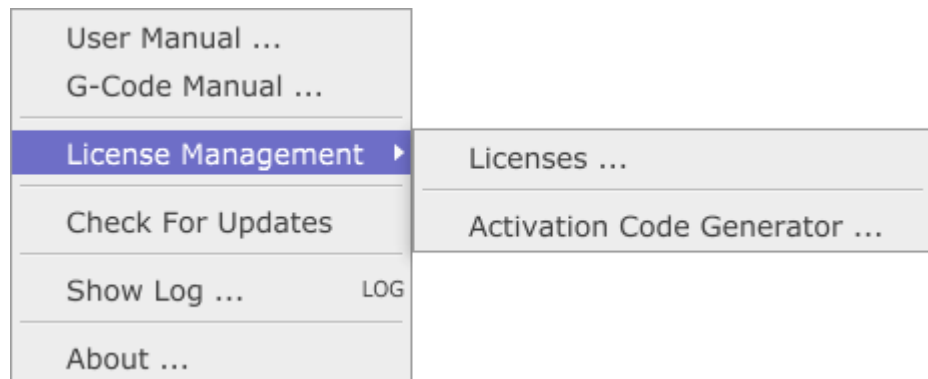

2.8.3.1 Licenses

Opens up a dialog where user can import license activation code and imports/exports license files.

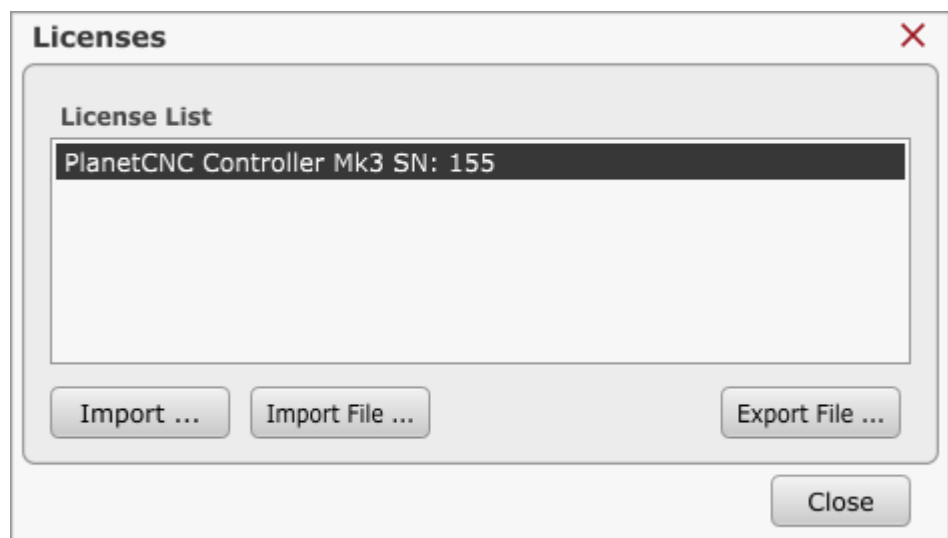

2.8.3.1.1 License list:

Displays license file(s) imported in PlanetCNC TNG software. License files have *.lic* file extension. They are located in main installation folder of PlanetCNC TNG software.

2.8.3.1.2 Import...

Opens up dialog where user can enter license activation code. User can paste license activation code using *c/p* keyboard keys or *Paste From Clipboard* button. Clicking *OK* button confirms license code.

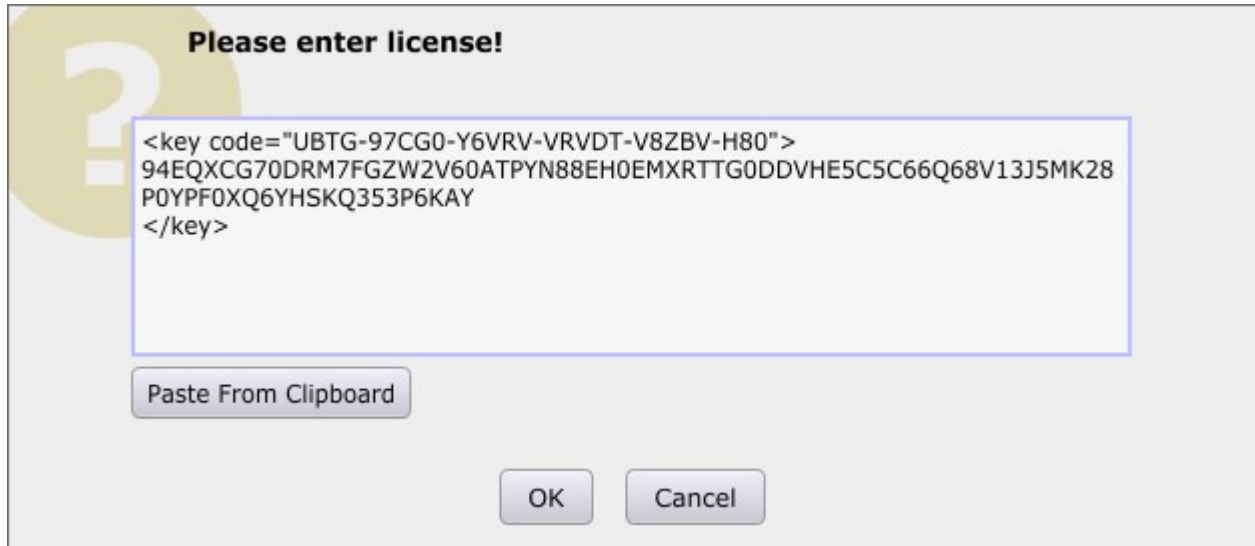

2.8.3.1.3 Import File

Imports license *.lic* file.

2.8.3.1.4 Export File

Exports license *.lic* file.

2.8.3.2 Activation Code Generator

Activation code generator displays controllers unique activation code. In order that code is displayed, controller needs to be selected under *Device List* so that becomes highlighted:

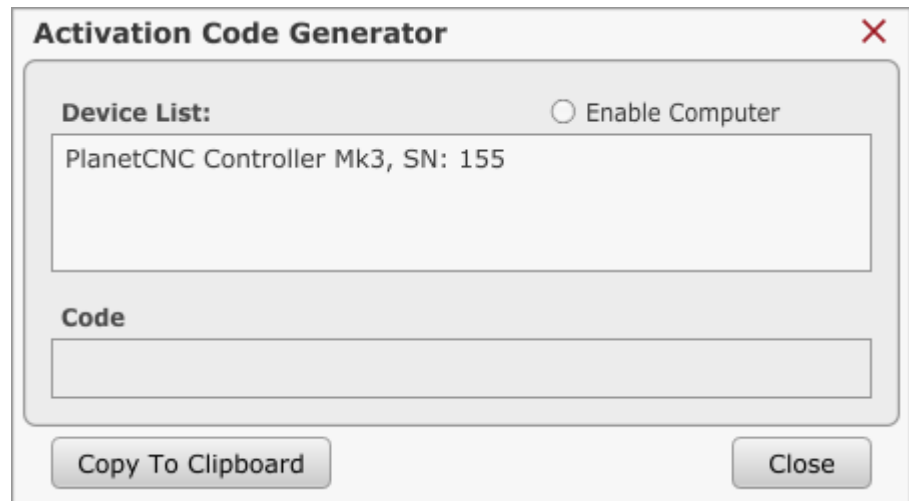

Activation Code Generator [X]

Device List: Enable Computer

PlanetCNC Controller Mk3, SN: 155

Code

Copy To Clipboard Close

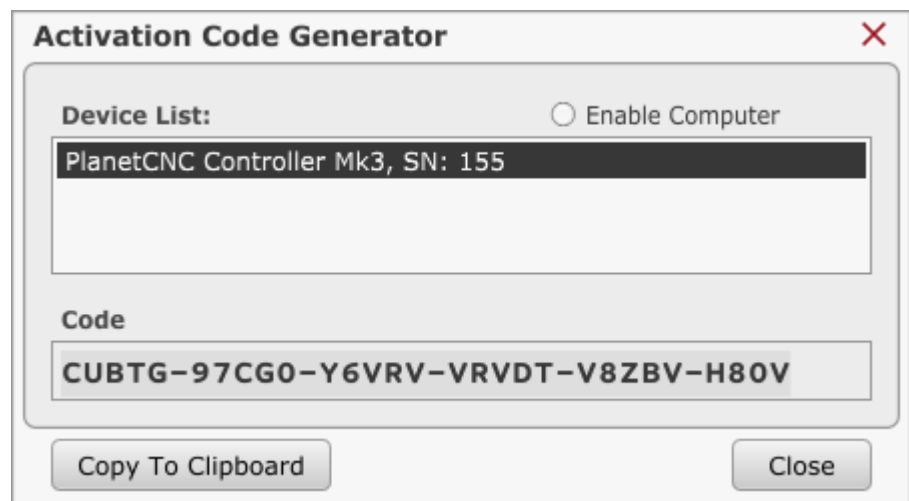

Activation Code Generator [X]

Device List: Enable Computer

PlanetCNC Controller Mk3, SN: 155

Code

CUBTG-97CG0-Y6VRV-VRVDT-V8ZBV-H80V

Copy To Clipboard Close

With *Copy To Clipboard* button, code is copied to clipboard and can be directly pasted to e.g. e-mail body text.

2.8.4 Check For Updates

Checks for software updates at PlanetCNC download page: <http://planet-cnc.com/software>

2.8.5 Show Log

2.8.6 About

Displays software version and firmware version of connected controller.



2.9 Settings

Settings panel allows setup and configuration of all software options and features. Settings allow automation and integration of many features to provide advanced functions and simplify or speed-up many common tasks. Required options are dependent on user machinery, ancillary hardware and application.

It's MOST IMPORTANT that software is appropriately configured before any attempt is made to control CNC machinery. Failure to do so, may result in serious injury or damage to machinery. With unknown or untested machinery, it's safer to keep initial motion rates below anticipated maximums. Emergency stop and limit switch hardware should be configured and tested before higher traverse or 'rapid' move rates are performed.

Settings shown in this section are examples. It's the users responsibility to ensure that safe and appropriate settings are applied to suit the controlled machine. Mk3 controller settings are used in examples. Most settings are applicable to other controllers. If specific settings for certain model of controller are required, this is noted in the text.

Some settings relate to hardware. These might be items like tool sensors, jog keyboards, MPG Pendants, tool-changers and so forth. If hardware is not available when software is configured, it can be installed and configured separately. It may be helpful to have hardware in place and operational before configuring related options. This allows testing or adjustment to determine safe and suitable parameters. Again, for reasons of safety, this is particularly the case with emergency stop and limit switch hardware.

2.9.1 General

Under 'General' tab you can insert settings description, measurement units, machine type, notes and settings password.

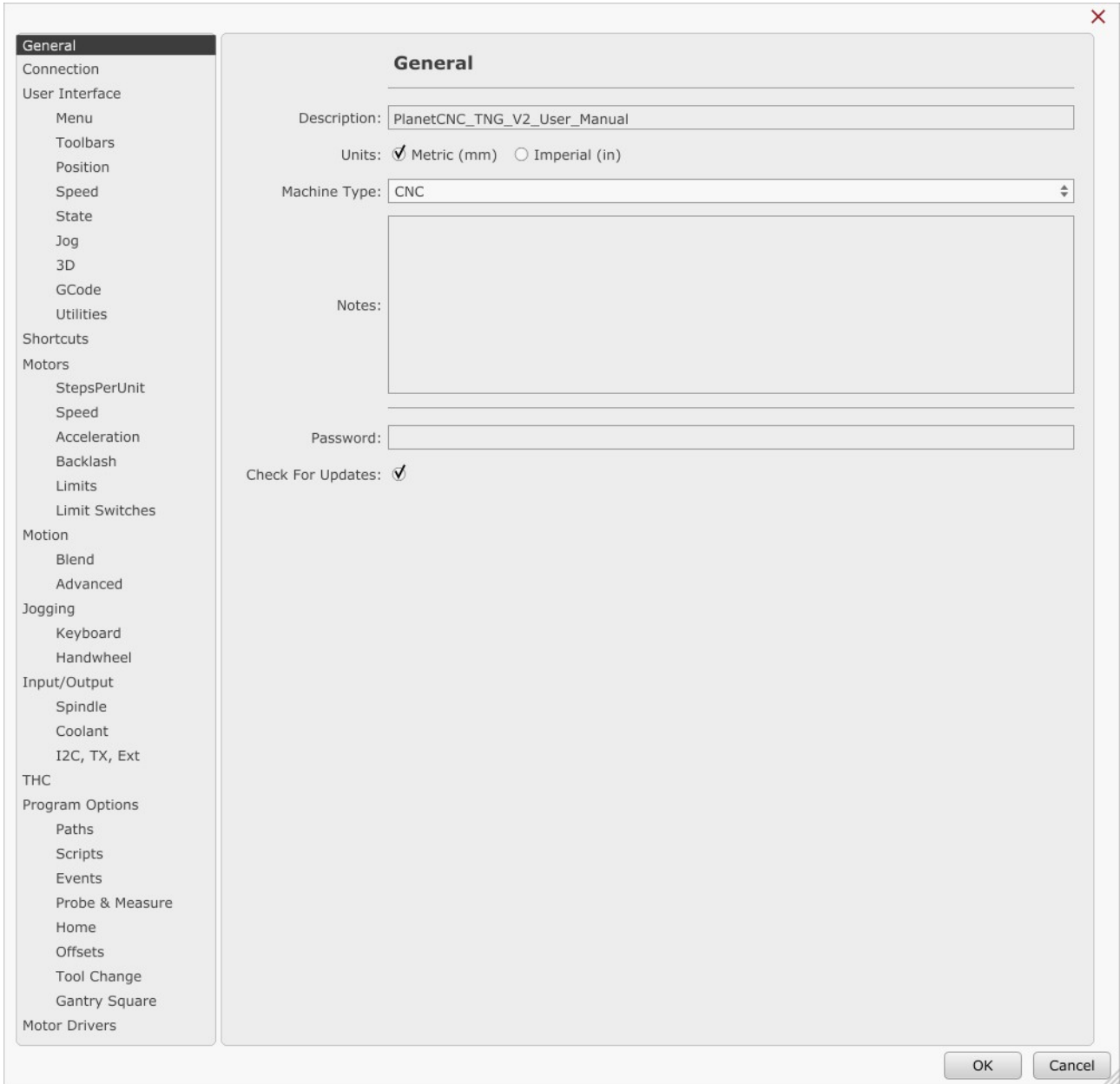

2.9.1.1 Description

Anything written in the description bar will be displayed at the top right corner of PlanetCNC TNG software window. This way you can easily indicate machine profile currently in use.

Description:

Description text is displayed at top right corner of PlanetCNC TNG window:

MyCNC_Router 

2.9.1.2 Units

Selected option sets measurement units which will be used in software. Metric (millimeters-mm) or Imperial (inches-in) units can be used. Depending on measurement unit set, all values in settings will be recalculated to measurement unit selected here.

2.9.1.3 Machine type

Select type of your machine. Option selected does not have an affect on any other setting(only for description purposes).

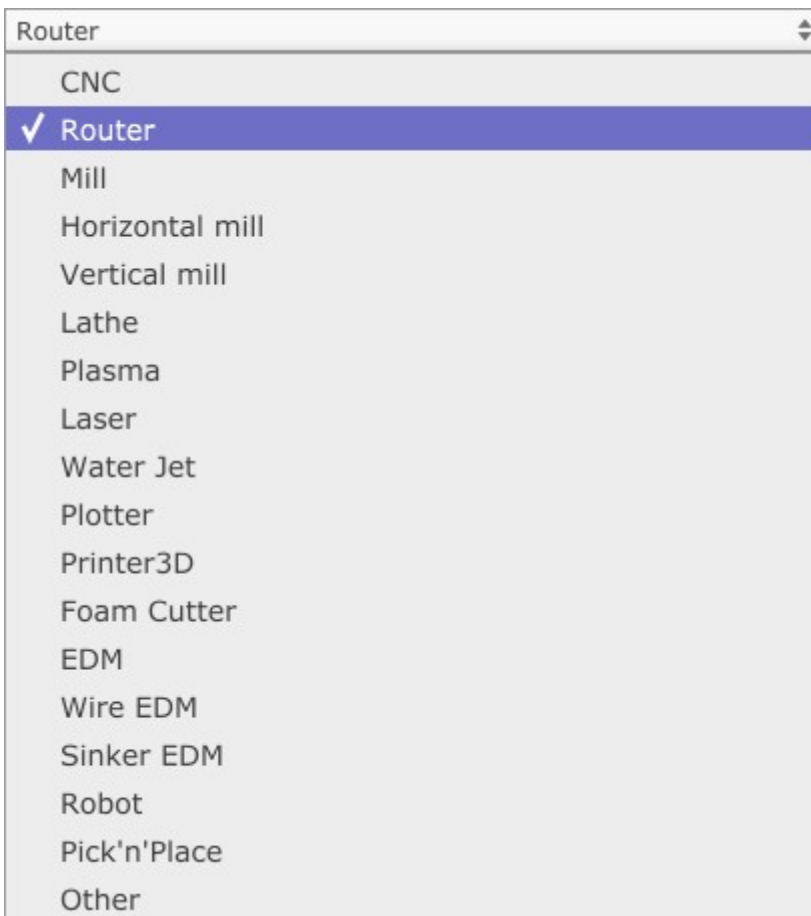

2.9.1.4 Notes

Here you can write notes describing your machine setup, setting configuration and any info that might be relevant to machine operator.

2.9.1.5 Password

If you wish to protect your settings configuration from being changed by another person, you can use password and protect settings from being modified.

Password:

Next time you open settings, software will require password:

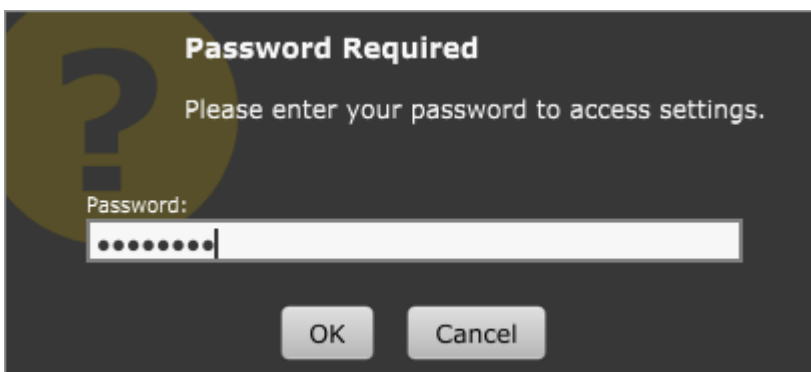

2.9.1.6 Check For Updates

With this option selected, software will automatically look for newer available software version.

2.9.2 Connection

Under 'Connection' tab you can set type of connection used for controller communication, computers network adapter IP number, primary controller selection and other motion controller based information.

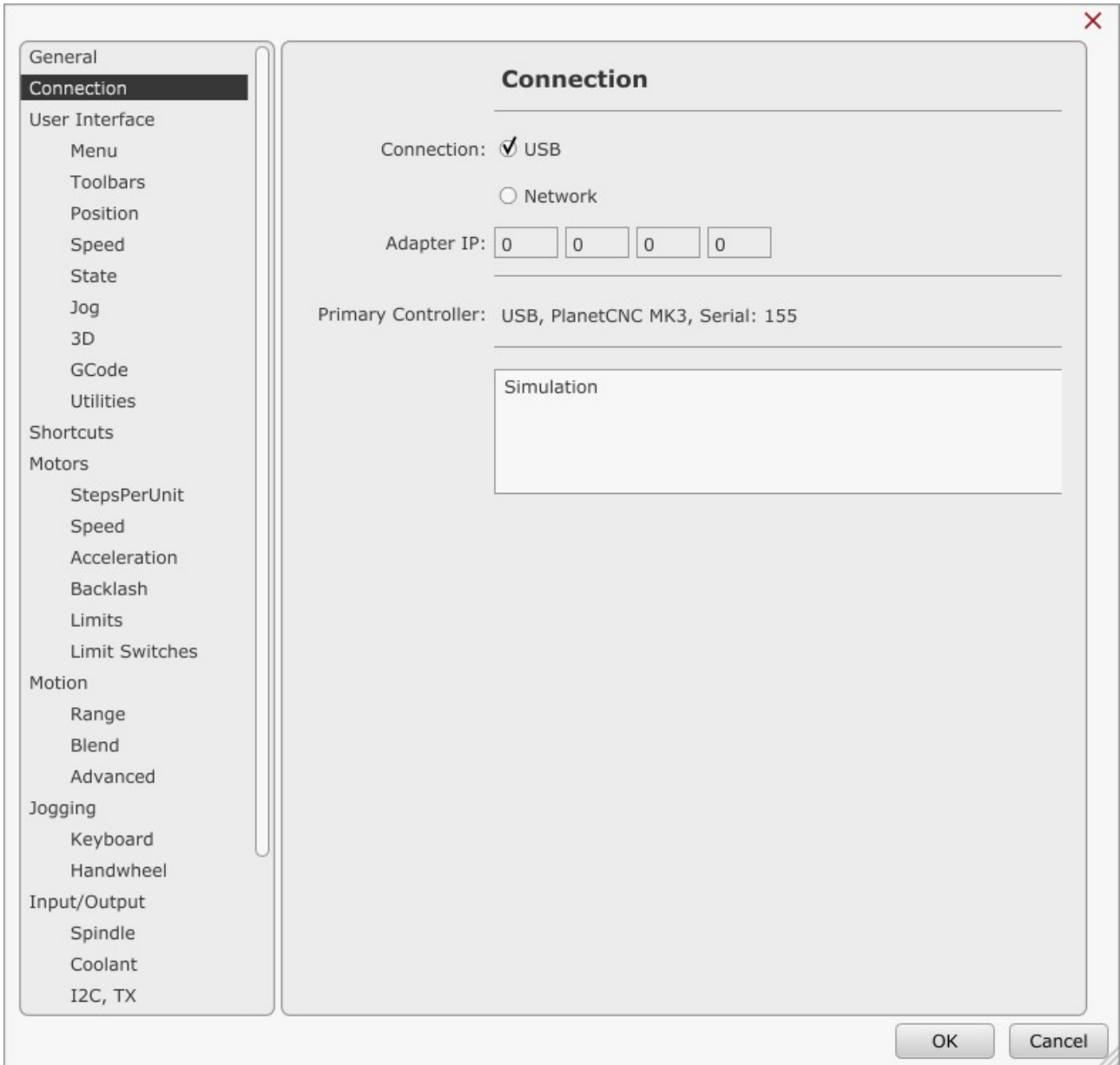

2.9.2.1 Connection

PlanetCNC motion controllers can use USB or Ethernet type of communication, depending on controller.

Mk3 supports both USB and Ethernet, while Mk3/4, Mk3DRV and Mk3ECO controllers support only USB communication.

2.9.2.1.1 USB:

When USB option is enabled, device list will be populated only with controller(s) that are connected to PC via USB port.

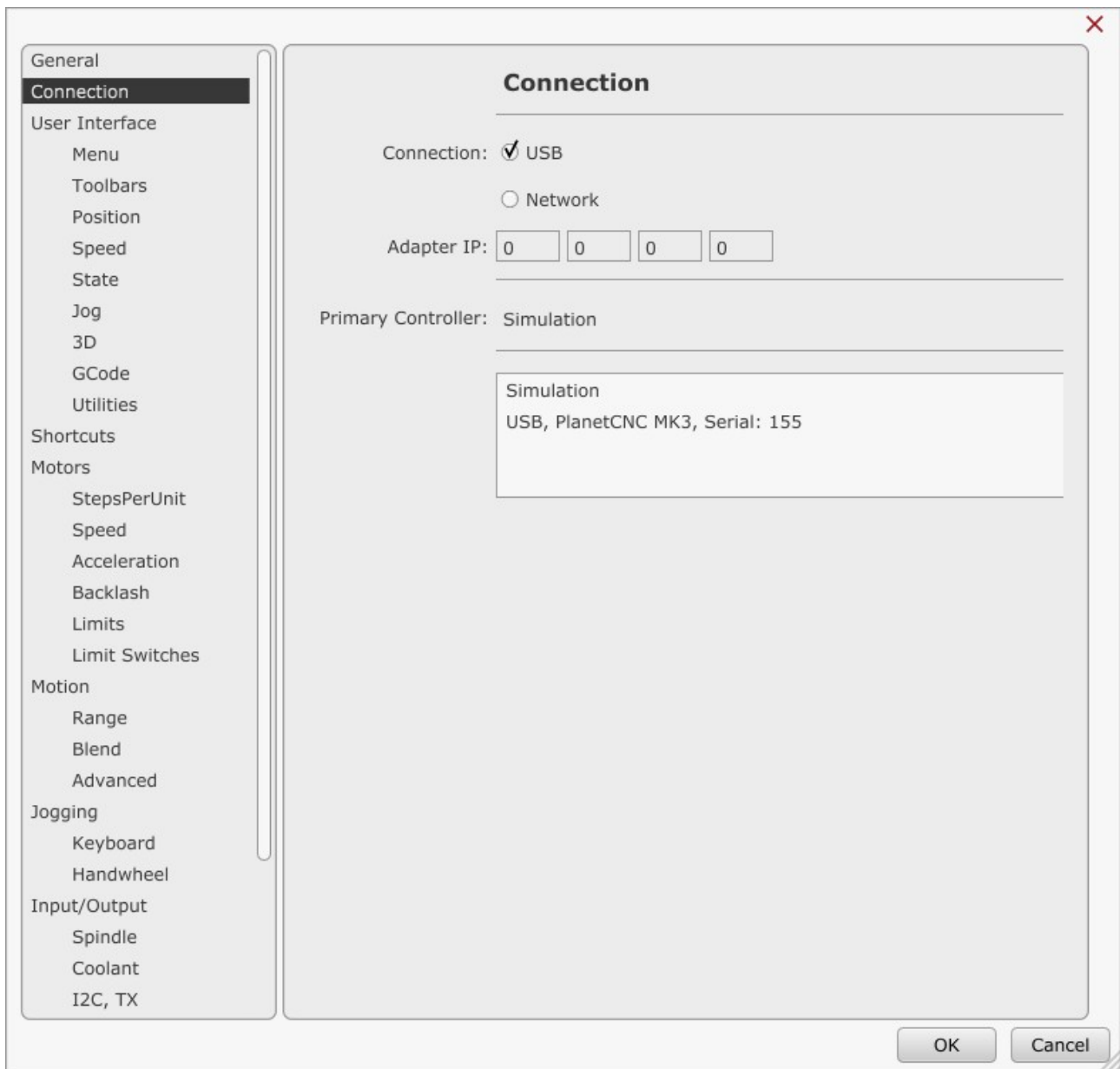

Device list provides user with basic controller info: USB, PlanetCNC Mk3, Serial: 155

USB: Type of connection

PlanetCNC MkXX: Version of PlanetCNC controller

Serial: Serial number of controller

If you highlight controller, you will be able to see additional info of controller (Info and Path bars will appear):

Info: Controllers firmware version(Version:).

Path: VID(Vendor ID) and PID(Product ID) number.

Path numbers 2.1.3.4 represent USB connection port hierarchy.

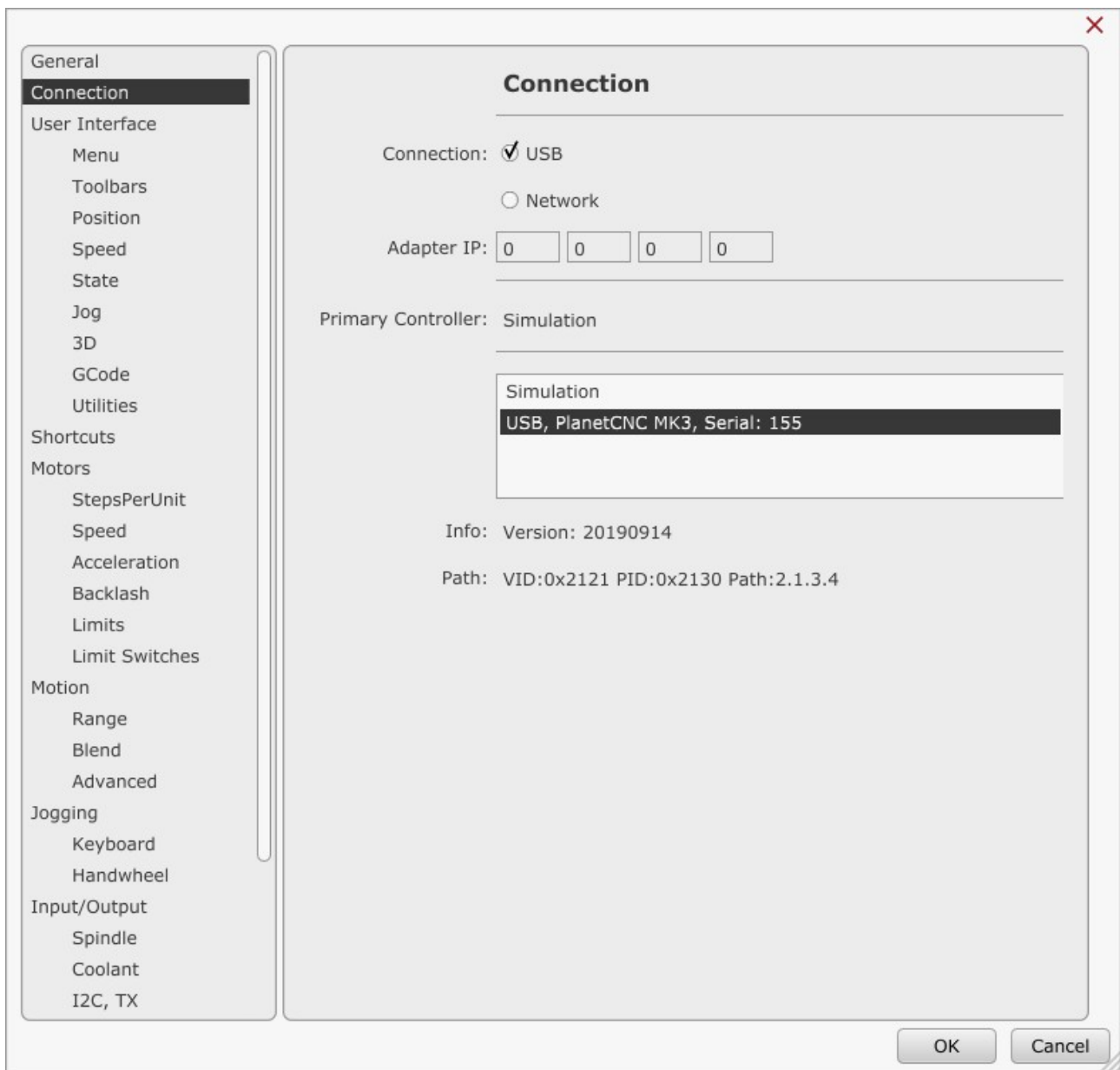

2.9.2.1.2 Network:

When Network option is enabled, controller list will be populated only with controller(s) that are connected with PC via network cable or are connected to network.

Device list provides user with basic controller info: NET, PlanetCNC MK3, Serial: 1300

NET: Type of connection

PlanetCNC Mk3, Mk34: Version of PlanetCNC controller

Serial: Serial number of controller

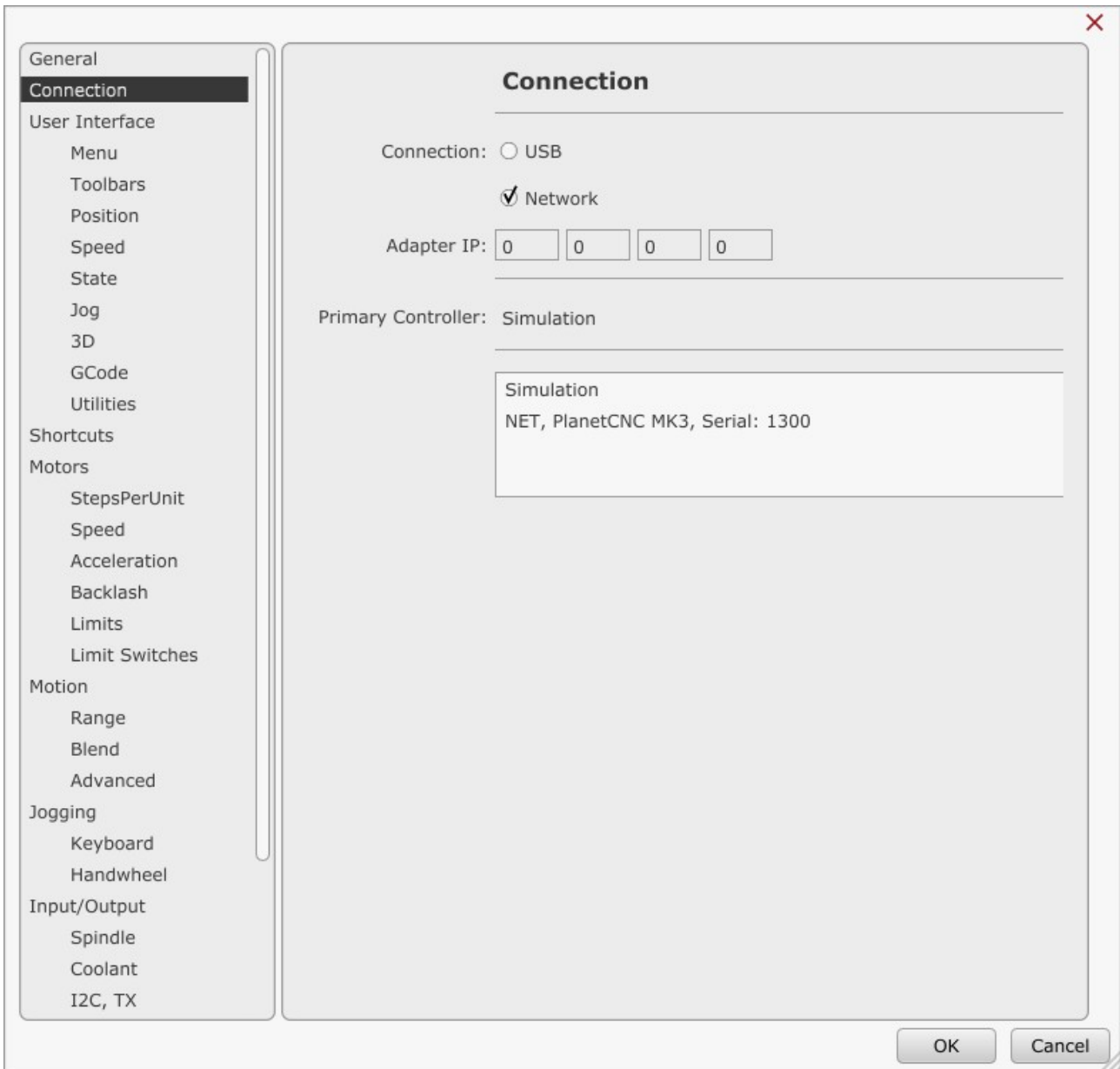

When you highlight controller, you will be able to see additional info of controller (Info, IP, Mask, MAC and DHCP bars will appear):

Info: Controllers firmware version(Version: 20170406).

IP: IP number of motion controller.

Mask: Network mask

MAC: MAC address of controller

DHCP option: Enables DHCP

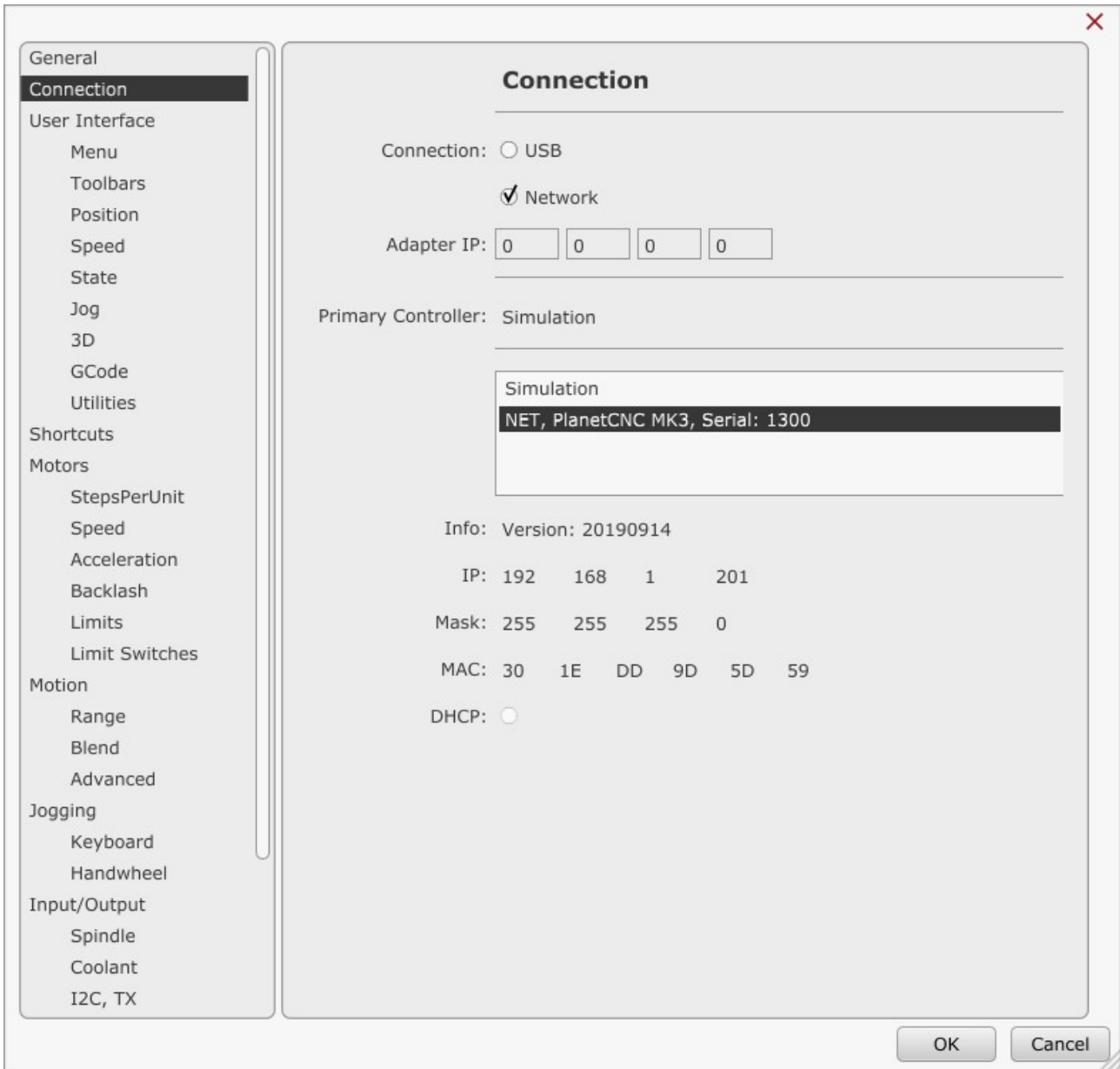

2.9.2.1.3 USB & Network:

If both, USB and Network options are enabled, controller list will be populated with controllers that are connected with PC via USB and Ethernet.

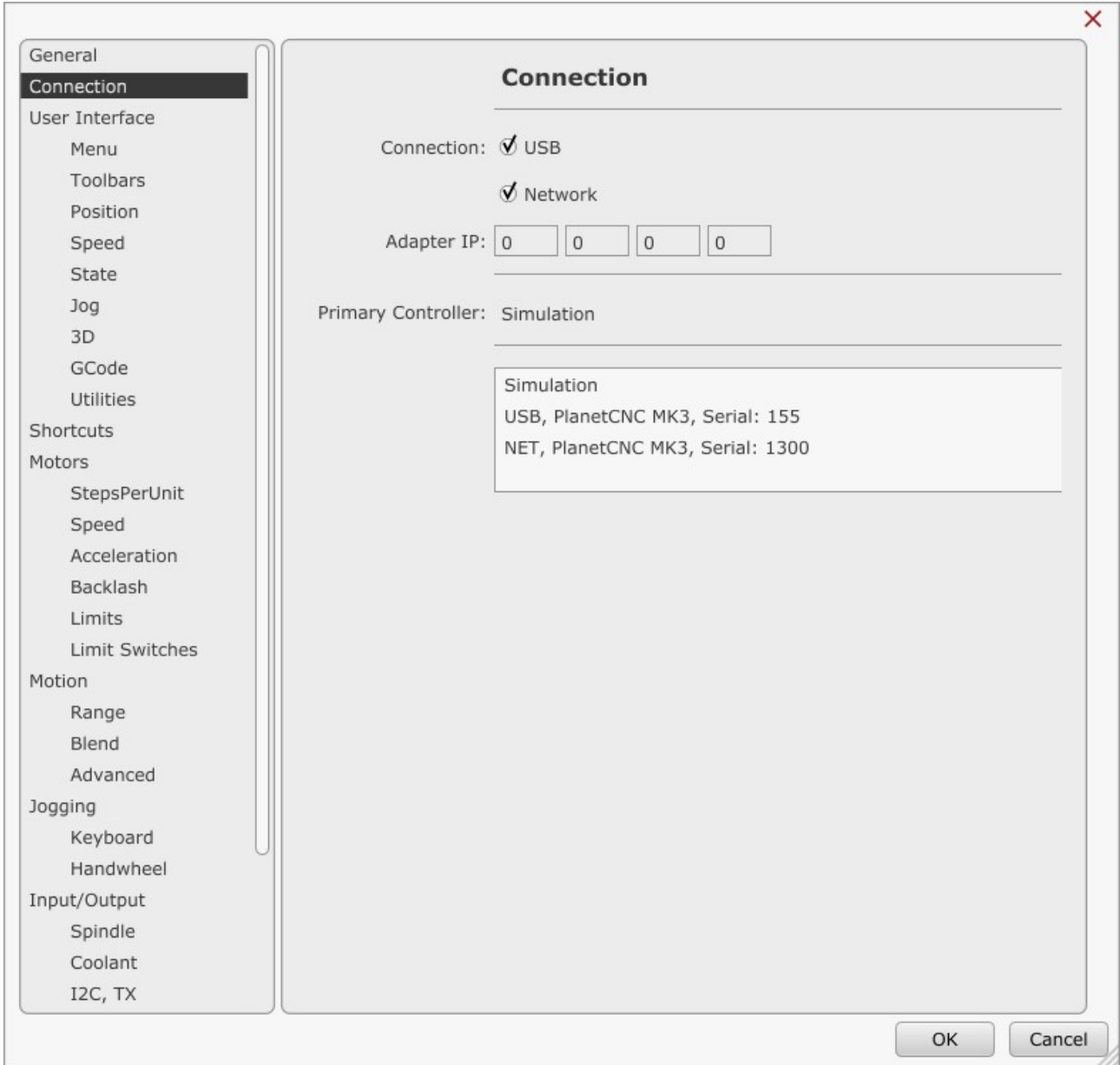

2.9.2.2 Adapter IP

Your computer is able to use numerous network adapters, which means your controller can be connected with computer through any of them. Here you can insert your computer's dedicated network adapter IP number.

2.9.2.3 Primary Controller:

Primary controller is controller which we select and assign as our main controller device. Primary controller is controller that will control CNC machine.

To assign controller as your primary controller you need to double click on it from the controller list.

You will notice that Primary Controller bar now displays your selected controller.

IMPORTANT: Selecting primary controller is necessary in order to control your CNC machine.

Connection

Connection: USB
 Network

Adapter IP:

Primary Controller: USB, PlanetCNC MK3, Serial: 155

Simulation

USB, PlanetCNC MK3, Serial: 155

Info: Version: 20190914

Path: VID:0x2121 PID:0x2130 Path:2.1.3.4

2.9.3 User Interface:

User interface is divided into separate segments:

Menu segment

Toolbar segment

Position segment

Speed segment

State segment

Jog segment

3D display segment

G-code segment

Utilities segment.

User can configure parameters of each segment, independently.

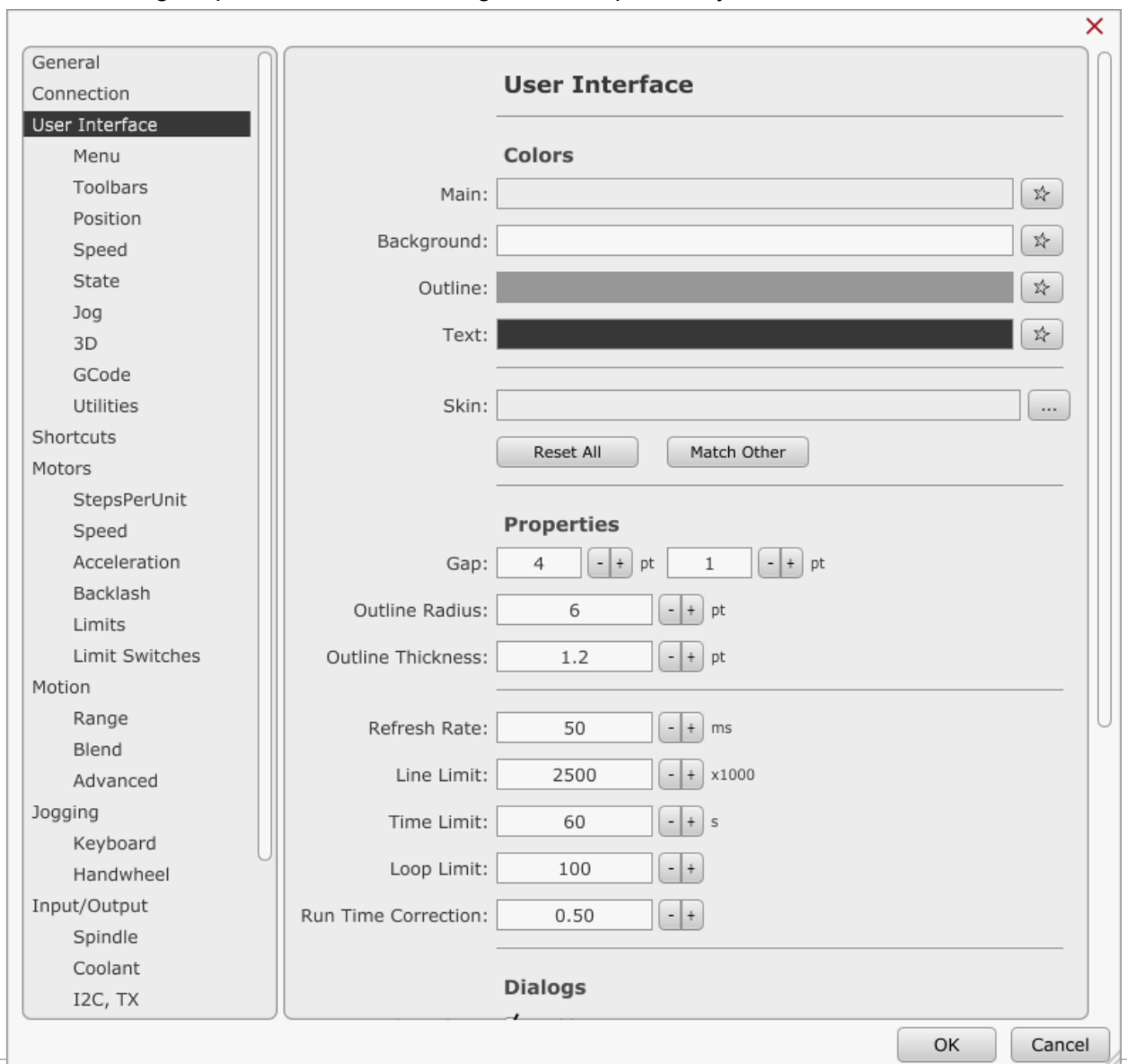

2.9.3.1 Colors

Each segment of user interface has multiple color parameters (for Text, Button, Label etc...). These color parameters can be set for each segment independently or by using “smart” color generator.

Color generator uses algorithm which calculates suitable color shades based on the main color. In such case user does not need to waste any time configuring suitable color combinations that would give him desired and useful color scheme.

2.9.3.1.1 Main

Based on *Main* color, color generator will generate and adjust suitable color shades of all color parameters of all segments.

In order to confirm new color scheme for all segments, user needs to click **Match Other** button.

Star shaped button will open color palette, from which user selects main color:

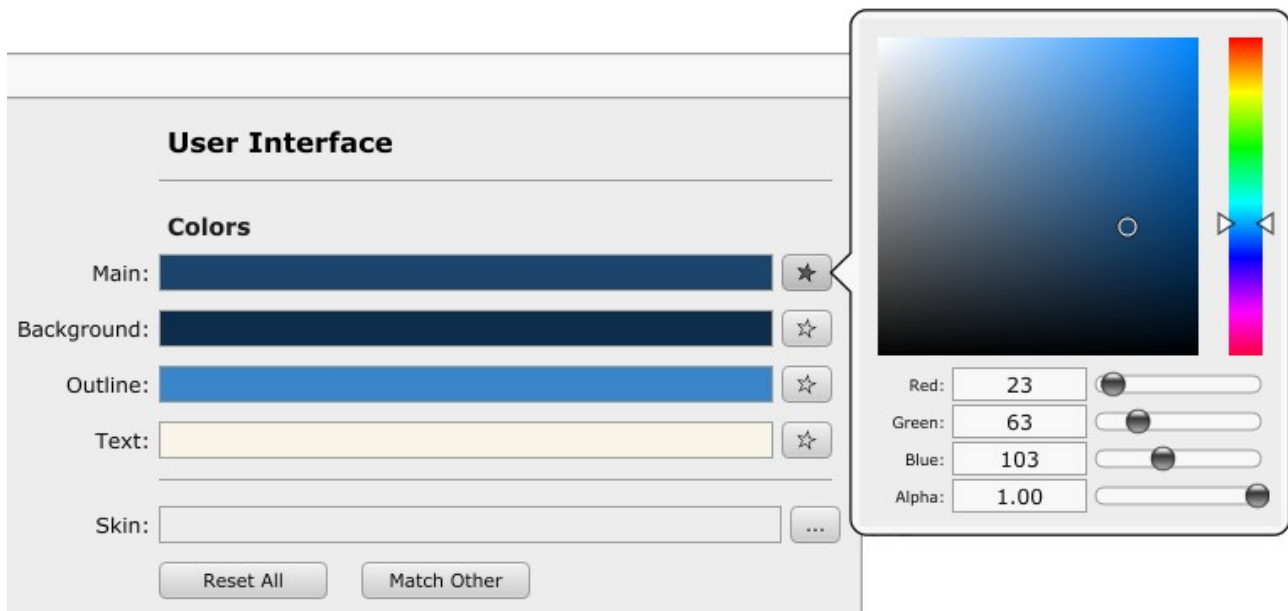

Color palette dialog offers user to select main color using color picker or RGB parameter sliders.

2.9.3.1.2 Background

Background color of user interface. This color can be set automatically using color generator or using color palette.

2.9.3.1.3 Outline

Outline color of segments. This color can be set automatically using color generator or using color palette.

2.9.3.1.4 Text

Text color of segments. This color can be set automatically using color generator or using color palette.

2.9.3.1.5 Skin

User interface can use skins. Skin is an image which will be used as a main pattern/theme for all segments.

You can load desired skin using browse button. Skin files are located in Skin folder of PlanetCNC TNG profile folder.

2.9.3.1.6 Reset All

Resets all color parameter values to default.

2.9.3.1.7 Match Other

Confirms new proposed color scheme for all segments. All segment colors will be automatically generated and set.

2.9.3.2 Properties

Properties

Gap: pt pt

Outline Radius: pt

Outline Thickness: pt

Refresh Rate: ms

Line Limit: x1000

Time Limit: s

Loop Limit:

Run Time Correction:

2.9.3.2.1 Gap:

These values define distance between neighbouring panels and between limiters within the panels.

Example:

Gap value set to 4:

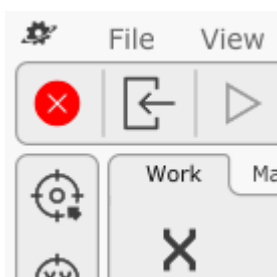

Gap value set to 16:

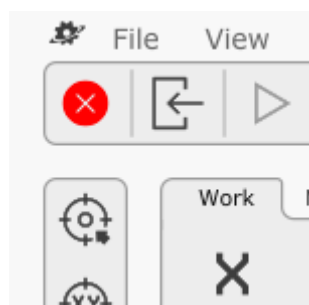

Gap limiter value set to 1:

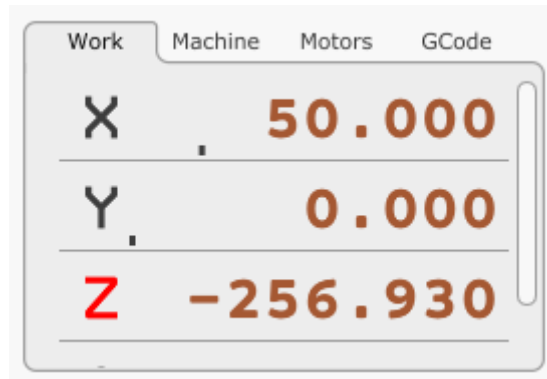

Work	Machine	Motors	GCode
X	.	50.000	
Y	.	0.000	
Z		-256.930	

Gap limiter value set to 12:

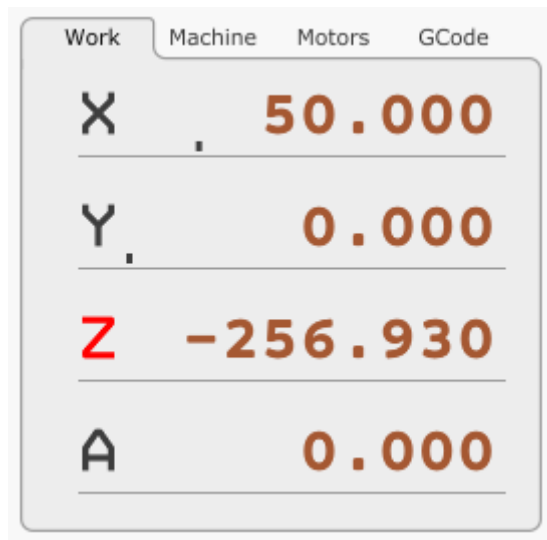

Work	Machine	Motors	GCode
X	.	50.000	
Y	.	0.000	
Z		-256.930	
A		0.000	

2.9.3.2.2 Outline Radius

This value defines corner radius of panels.

Example:

Outline Radius set to 6:

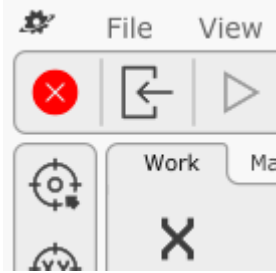

Outline Radius set to 18:

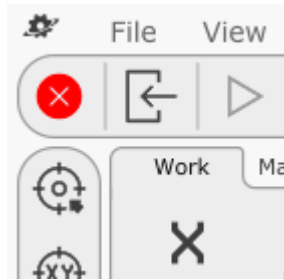

2.9.3.2.3 Outline Thickness

This value defines panel outline thickness.

Example:

Outline Thickness set to 1.2:

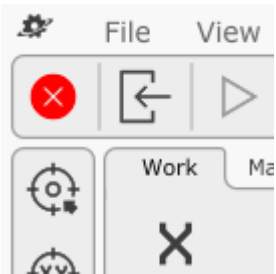

Outline Thickness set to 3.5:

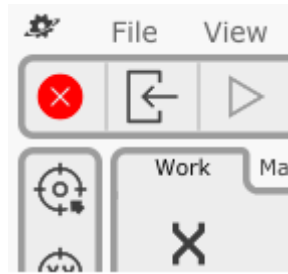

2.9.3.2.4 Refresh Rate

This parameter sets user interface display refresh time. Value inserted is time in milliseconds, time after displayed PlanetCNC TNG interface will refresh.

2.9.3.2.5 Line Limit

This parameter sets max number of program g-code lines that can be loaded into PlanetCNC TNG software. Toolpath will be displayed only to the point of last g-code line loaded.

Note that even if g-code program is not loaded and tool path is not displayed completely, software will still execute program in its entirety.

2.9.3.2.6 Time Limit:

Value inserted is time in seconds after which PlanetCNC TNG software stops loading of g-code program.

Note that even if g-code program is not loaded and tool path is not displayed completely, software will still execute program in its entirety.

2.9.3.2.7 Loop Limit

Value inserted is number of loops (used as o-word subroutines e.g.: While/Endwhile, Repeat) after which PlanetCNC TNG software stops loading of g-code program.

Note that even if g-code program is not loaded and tool path is not displayed completely, software will still execute program in its entirety.

2.9.3.2.8 Run Time Correction

Value inserted is factor which helps with approximation of job run-time evaluation that is displayed at the bottom right corner of PlanetCNC TNG main window.

2.9.3.3 Dialogs

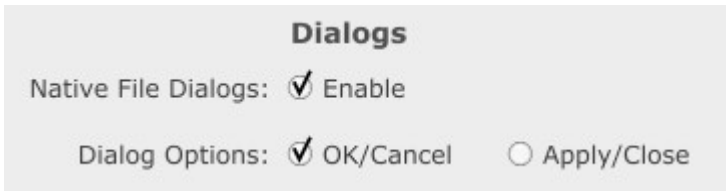

2.9.3.3.1 Native File Dialogs

Menu items located under 'File' menu can be displayed in your computers native OS form or in PlanetCNC TNG software form.

Click Enable button to enable use of Native File Dialogs.

Native File Dialogs enabled:

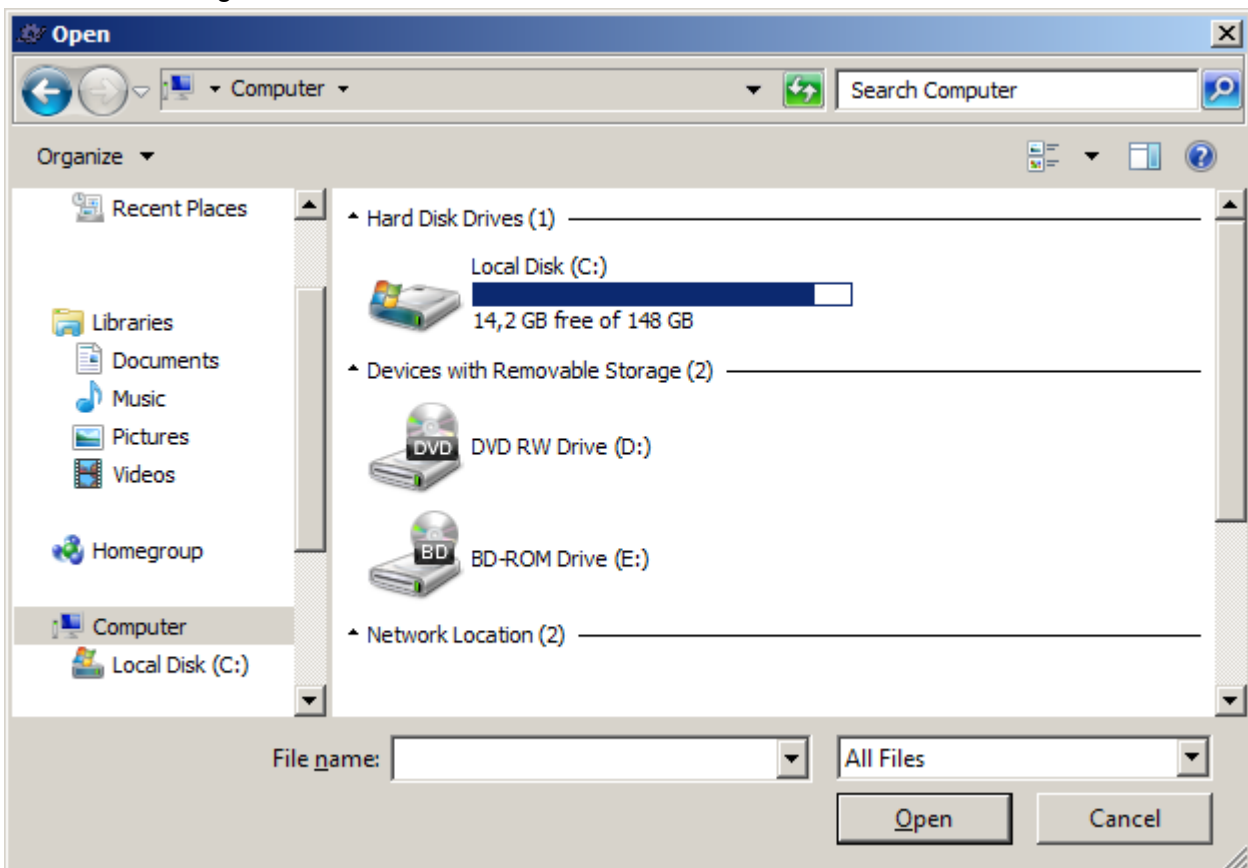

Native File Dialogs disabled:

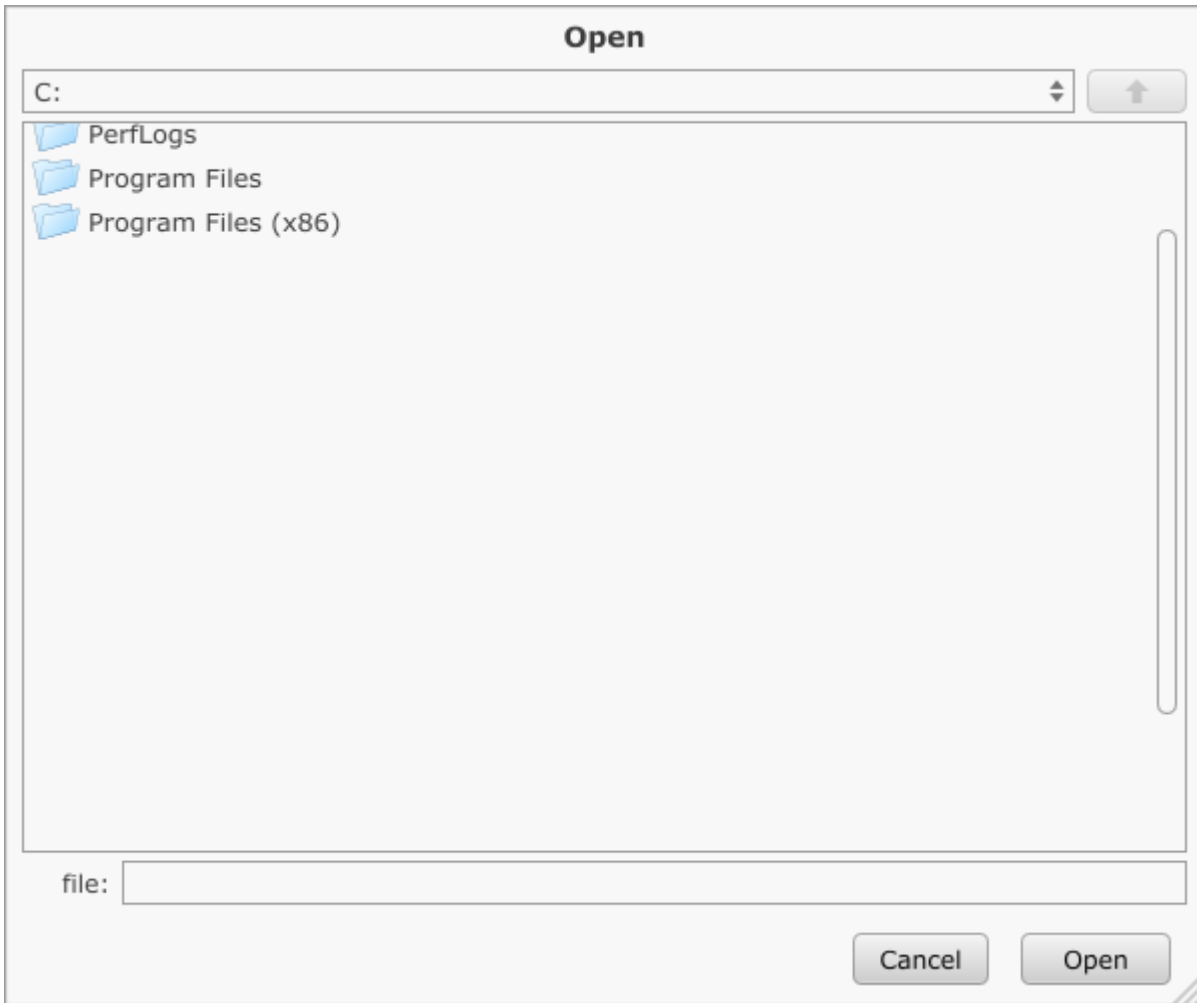

2.9.3.3.2 Dialog Options

OK/Cancel:

Program feature dialog will use OK and Cancel buttons. OK button confirms parameter configuration and closes the dialog. Changes to the program will be made after you click *Redraw* from Program menu.

Cancel button closes dialog. No changes will be made.

Example:

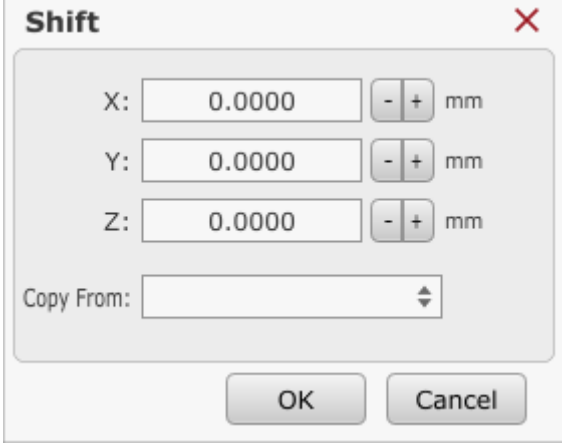

The screenshot shows a dialog box titled "Shift" with a red close button in the top right corner. Inside the dialog, there are three input fields for X, Y, and Z coordinates, each with a value of 0.0000 and a unit of mm. Each input field has a minus sign and a plus sign button to its right. Below these fields is a "Copy From:" label followed by a dropdown menu. At the bottom of the dialog are two buttons: "OK" and "Cancel".

Apply/Close:

Program feature dialog will use Apply and Close buttons. Apply button confirms parameter configuration. Changes to the program will be made after you close the dialog and click *Redraw* from Program menu. If *Auto Redraw* is enabled, changes to the program will be made instantly after Apply button clicked.

Close button closes dialog. No changes will be made.

Example:

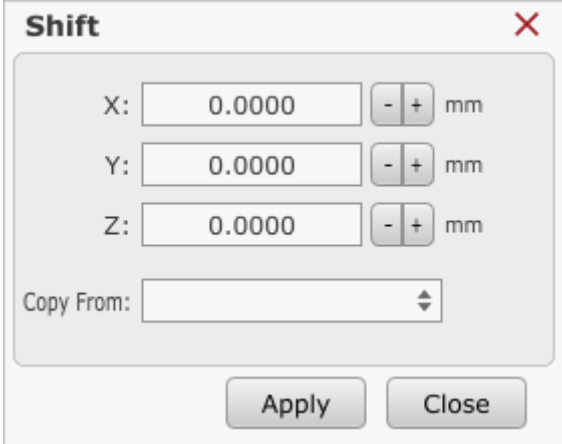

The screenshot shows a dialog box titled "Shift" with a red close button in the top right corner. Inside the dialog, there are three input fields for X, Y, and Z coordinates, each with a value of 0.0000 and a unit of mm. Each input field has a minus sign and a plus sign button to its right. Below these fields is a "Copy From:" label followed by a dropdown menu. At the bottom of the dialog are two buttons: "Apply" and "Close".

2.9.3.4 Commands

Commands

Spindle Command: Native Uses M-Code

Coolant Command: Native Uses M-Code

Auto Redraw: On Program Cmd On Machine Cmd

2.9.3.4.1 Spindle Command

Native:

When Spindle On/Off button from toolbar is used, software uses default M3 g-code behaviour.

Uses M-code:

When Spindle On/Off button from toolbar is used, software uses M3 g-code script behaviour.

2.9.3.4.2 Coolant Command

Native:

When Coolant On/Off buttons from toolbar are used, software uses default M7,M8 g-code behaviour.

Uses M-code:

When Coolant On/Off buttons from toolbar are used, software uses M7,M8 g-code script behaviour.

2.9.3.4.3 Auto Redraw

On Program Cmd:

If any program changes were made using *Program* menu dialogs, this parameter, when enabled, will automatically reload changes after *Program* dialog is closed.

On Machine Cmd:

If any program changes were made using *Machine* menu dialogs, this parameter, when enabled, will automatically reload changes after *Machine* dialog is closed.

2.9.4 Menu

Menu bar is located horizontally at the top of the user interface. It populates menus: *File, View, Program, Machine, Help*.

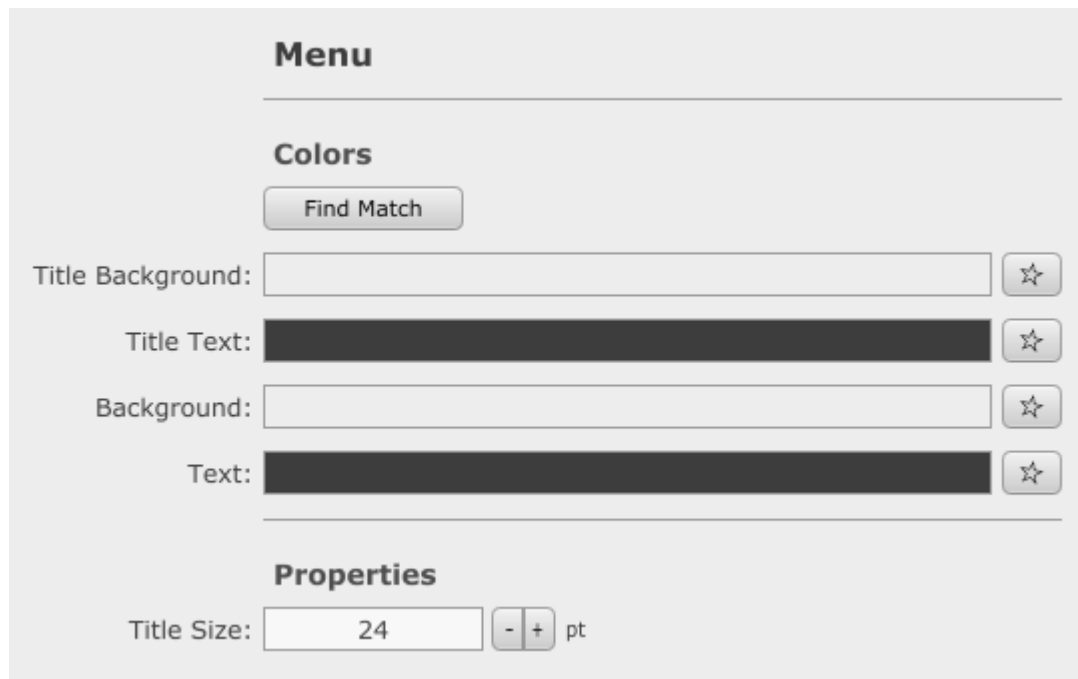

2.9.4.1 Colors

Find Match:

Based on selected *Main* color, color generator will generate and adjust suitable color shade for all *Menu* segment color parameters.

Title Background:

Background color of menu's Title bar. This color can be set automatically using color generator or using color palette.

Title Text:

Menu's Title text color. This color can be set automatically using color generator or using color palette.

Background:

Menu background color. This color can be set automatically using color generator or using color palette.

Text:

Menu items text color. This color can be set automatically using color generator or using color palette.

Example:

Title Background set to red, and Background set to yellow color:

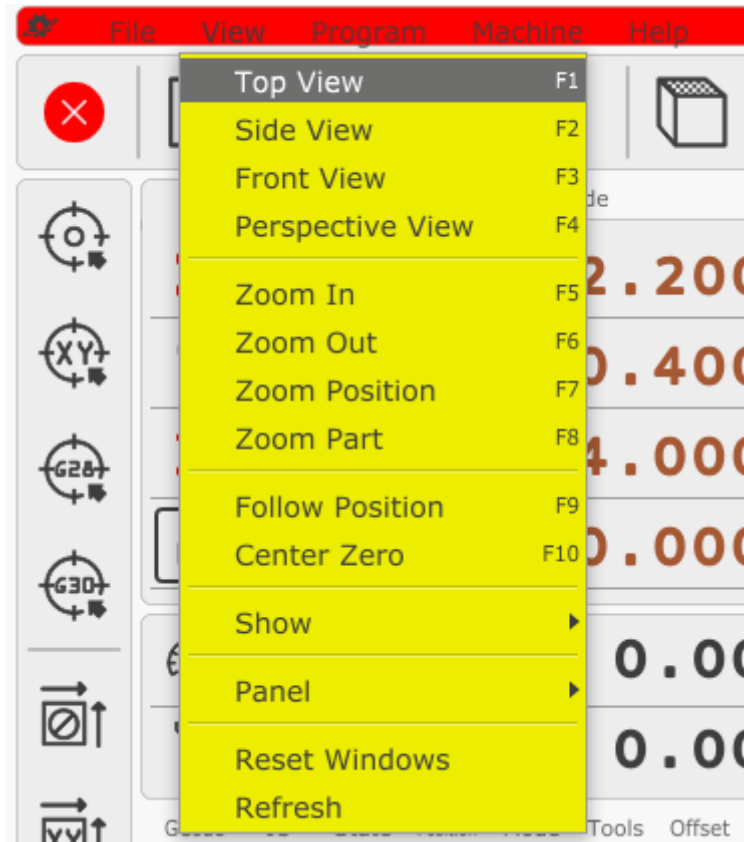

2.9.4.2 Properties

Title Size:

With this parameter you set the size of the titlebar items as also menu items.

Example: Title size set to 52

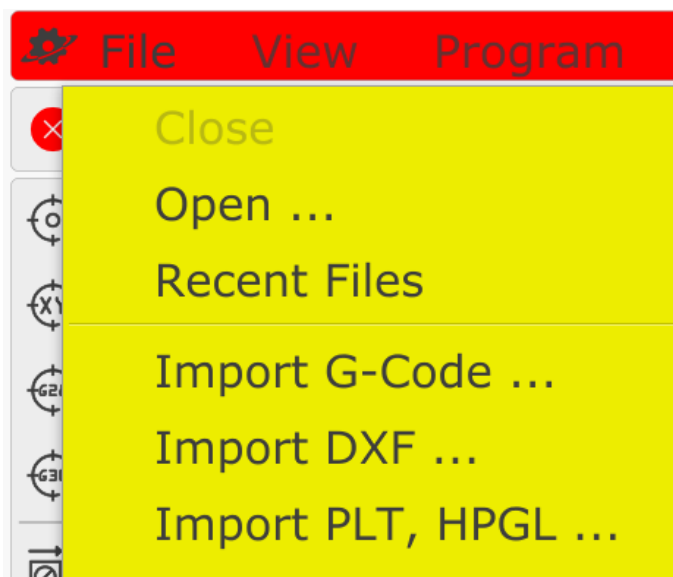

2.9.5 Toolbars

Toolbars are located vertically left and right of the user interface and horizontally at the top and bottom of the user interface.

Toolbars

Colors

Find Match

Background: ☆

Button: ☆

Button Down: ☆

Button Alert: ☆

Properties

Size: - + pt

Buttons: Hide Show

Hints: Hide Show

2.9.5.1 Colors

Find Match:

Based on selected *Main* color, color generator will generate and adjust suitable color shade for all *Toolbars* segment color parameters.

Background:

Background color of Toolbar segment. This color can be set automatically using color generator or using color palette.

Button:

Button icon color. This color can be set automatically using color generator or using color palette.

Example:

Background color of toolbars set to blue:

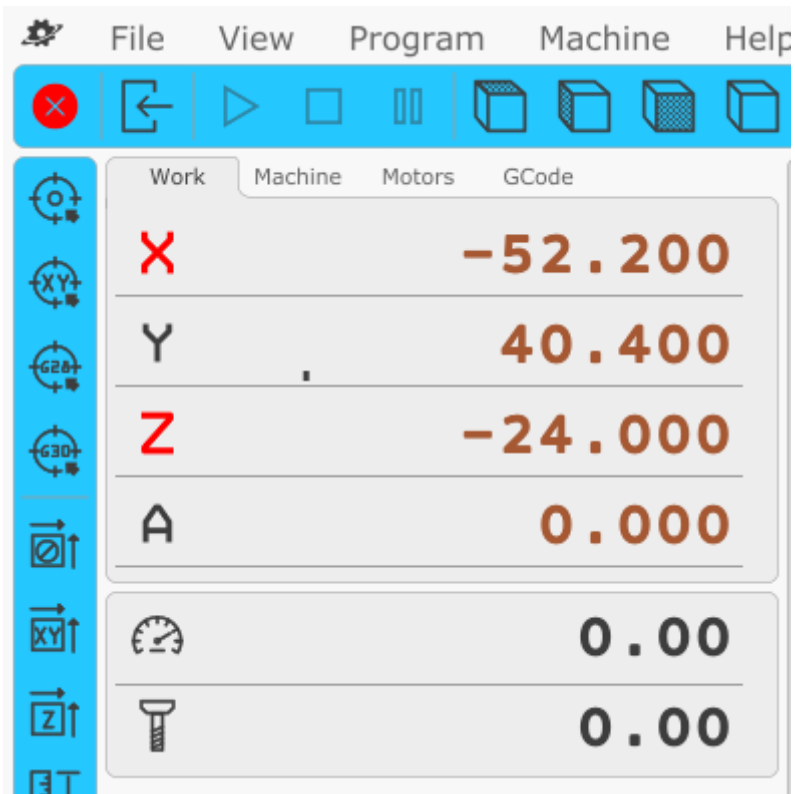

Button Down:

Toolbar button active state color. Button will change its color when it is used either directly from toolbar or when its modal state is active (e.g. M3, M7, M8).

Idle button **example**:



Active (down) button **example**:

**Button Alert:**

Button alert color. Button will change its color when it is in alert mode.

Idle pause button **example** (pause enabled):



Alert pause button **example** (pause disabled):



2.9.5.2 Properties:

Size:

With this parameter you set the size of the toolbars.

Example:

Toolbar size set to 60.

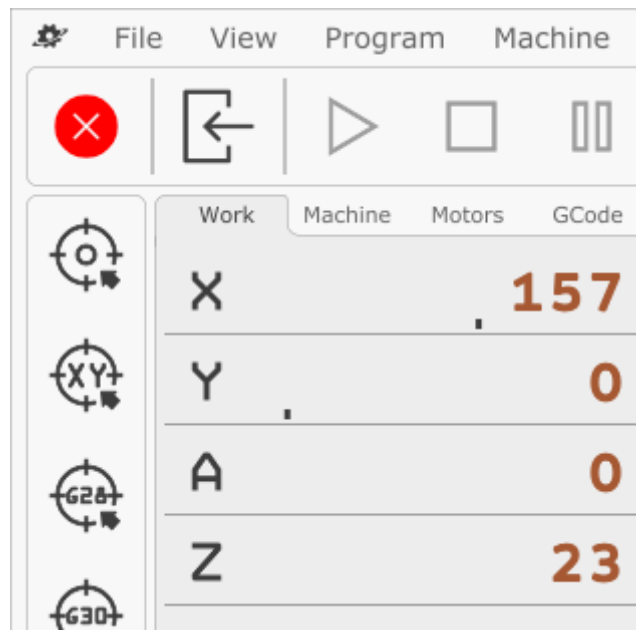

Buttons:

This option allows user to hide or show buttons.

Hide: Hides all buttons.

Show: Displays all buttons.

Example:

Toolbar buttons are hidden.

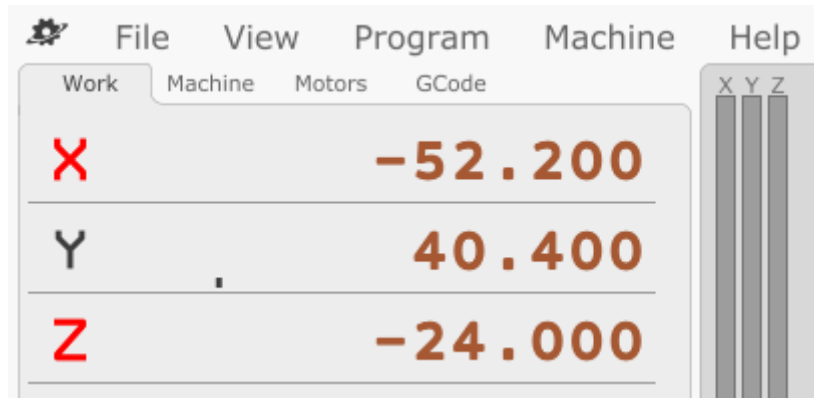
**Hints:**

Toolbar hints are pop-up clouds with names of toolbar buttons. Toolbar hints appear whenever you hover with your mouse over specific toolbar button.

Hide: Toolbar hints will not appear.

Show: Toolbar hints will appear.

Example:

Toolbar hints enabled:

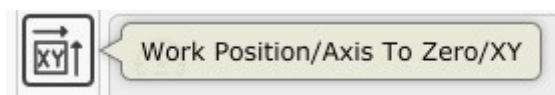

2.9.6 Position

Under *Position* tab you can set color parameters, number of displayed axis rows, number of decimals displayed, set axis name to desired row and position display button behaviour.

Position

Colors

Background:

Work:

Machine:

Motors:

GCode:

Button:

Button Lim-:

Button Lim+:

Properties

Size: pt

Number of Rows:

Number of Decimals:

Row 1: <input style="width: 50px;" type="text" value="X"/>	Row 2: <input style="width: 50px;" type="text" value="Y"/>	Row 3: <input style="width: 50px;" type="text" value="Z"/>
Row 4: <input style="width: 50px;" type="text" value="A"/>	Row 5: <input style="width: 50px;" type="text" value="B"/>	Row 6: <input style="width: 50px;" type="text" value="C"/>
Row 7: <input style="width: 50px;" type="text" value="U"/>	Row 8: <input style="width: 50px;" type="text" value="V"/>	Row 9: <input style="width: 50px;" type="text" value="W"/>

Commands

Work

Button: Disable Work Position Coordinate System

Machine

Button: Disable Machine Position

2.9.6.1 Colors

Find Match:

Based on selected *Main* color, color generator will generate and adjust suitable color shade for all *Toolbars* segment color parameters.

Background:

Background color of *Position* segment. This color can be set automatically using color generator or using color palette.

Example:

Background color set to green.

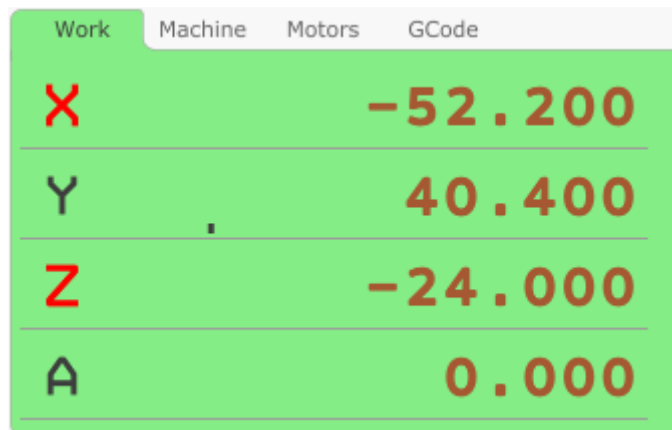

Work	Machine	Motors	GCode
X			-52.200
Y	.		40.400
Z			-24.000
A			0.000

Work:

Color of *Work* position values. This color can be set automatically using color generator or using color palette.

Machine:

Color of *Machine* position values. This color can be set automatically using color generator or using color palette.

Motors:

Color of *Motors* position values. This color can be set automatically using color generator or using color palette.

GCode:

Color of *GCode* position values. This color can be set automatically using color generator or using color palette.

Example:

Work position values color set to purple.

Work	Machine	Motors	GCode
X			-52.200
Y	.		40.400
Z			-24.000
A			0.000

Button:

Color of axis button of position display. This color can be set automatically using color generator or using color palette.

Button Lim-:

Color of axis button when machine reaches negative limit value of machine area. This color can be set automatically using color generator or using color palette.

Button Lim+:

Color of axis button when machine reaches positive limit value of machine area. This color can be set automatically using color generator or using color palette.

Example:

Button color set to blue and button Lim- color set to orange.

Work	Machine	Motors	GCode
X			-52.200
Y	.		40.400
Z			-24.000
A			0.000

2.9.6.2 Properties

Size:

Inserted value sets size of axis position values for Work, Machine, Motors and Gcode position values.

Example:

Size of axis position values set to 70.

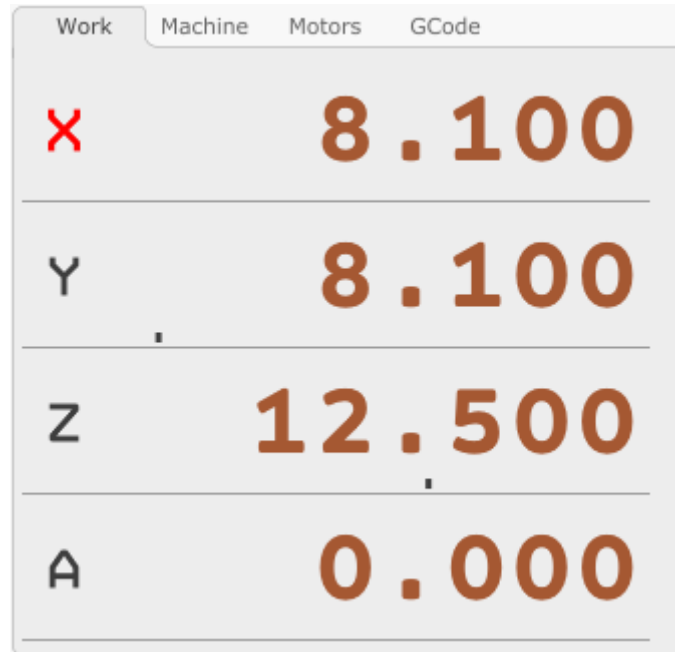

Work	Machine	Motors	GCode
X	8	100	
Y	8	100	
Z	12	500	
A	0	000	

Number of Rows:

Sets number of displayed axis rows under *Work*, *Machine*, *Motors* and *Gcode* tabs.

Number of Decimals:

Sets number of displayed decimals for *Work*, *Machine*, *Motors* and *Gcode* position values.

Row 1-9:

Assigns axis letter to desired row. Configured axis letter layout will be displayed for *Work*, *Machine*, *Motors* and *Gcode* position display.

Example:

Number of rows set to 9, Number of decimals set to 3 and mixed axis letters assigned to different rows.

Properties

Size: - + pt

Number of Rows: - +

Number of Decimals: - +

Row 1: Row 2: Row 3:

Row 4: Row 5: Row 6:

Row 7: Row 8: Row 9:

Final result of position display as per configuration above:

Work	Machine	Motors	GCode
X			8.100
Y	.		8.100
A			0.000
Z			12.500
U			0.000
C			0.000
V			0.000
B			0.000
W			0.000

2.9.6.3 Commands

Work:

Button:

Disable:

Use of buttons for zeroing Work position value is disabled.

Work Position:

Use of buttons for zeroing Work position value is enabled.

Coordinate System

Use of buttons for zeroing active Coordinate System position value is enabled.

Machine:

Button:

Disable:

Use of buttons for zeroing Machine position value is disabled.

Machine Position:

Use of buttons for zeroing Machine position value is enabled.

2.9.7 Speed

Speed

Colors

Background:

Value:

Button:

Button Active:

Button Alert:

Speed

Hide Show

Size: pt

Override: Min Max Step

Override: Min Max Step

Slider Feed Traverse Both

Spindle

Hide Show

Size: pt

Override: Min Max Step

Spindle RPM: As Set From Index From Encoder

2.9.7.1 Colors

2.9.7.1.1 Find Match:

Based on selected *Main* color, color generator will generate and adjust suitable color shade for all *Speed* segment color parameters.

2.9.7.1.2 Background:

Background color of *Speed* segment. This color can be set automatically using color generator or using color palette.

Example:

Background color set to pink.



2.9.7.1.3 Value:

Color of override buttons, slider and displayed value.

Example:

Color override buttons, slider and displayed value set to light blue.

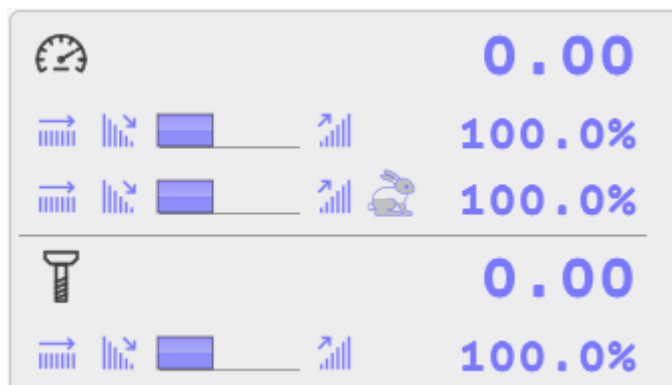

2.9.7.1.4 Button:

Override button icon color. This color can be set automatically using color generator or using color palette.

Example:

Override button icon color set to green.

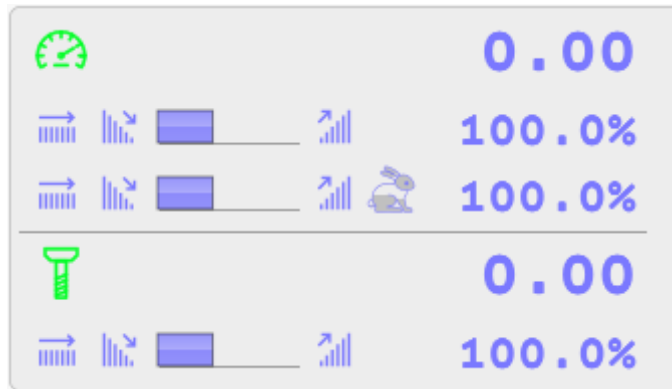

2.9.7.1.5 Button Active:

Button override active state color. Button icon will change its color when speed override is set either directly from *Speed* segment or when it is used from *Machine/Options/Override*.

Example:

Button Active color as per default setting – color orange

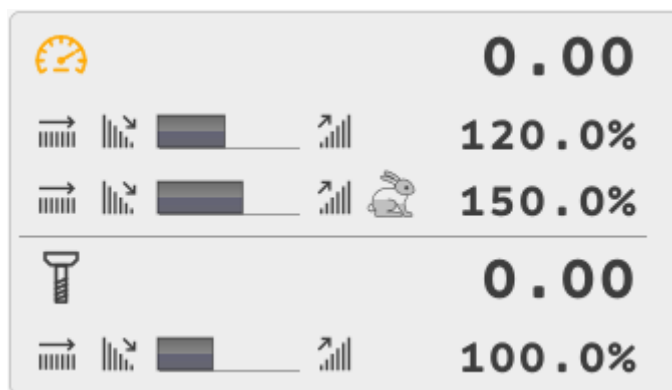

2.9.7.1.6 Button Alert:

Override button alert color. Button will change its color when it is in alert mode. For instance, when Homing procedure is initiated, software will automatically disable override option for safety reasons- button will turn red.

Example:

Feed Override button in idle mode (override enabled):

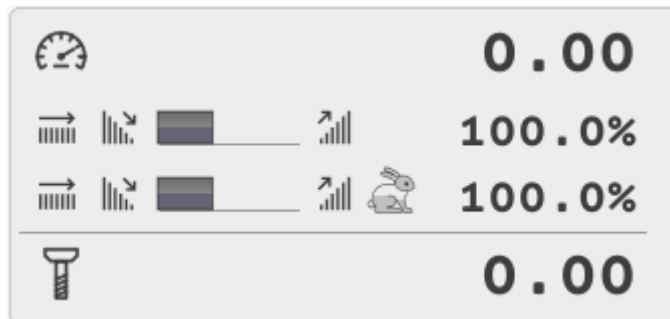

Feed Override button in alert mode (override disabled):

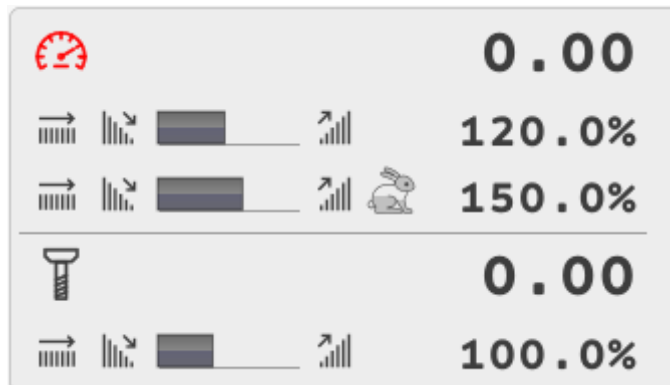

2.9.7.2 Speed

Group of settings that configure display of feed and rapid speed parameters.

2.9.7.2.1 Hide:

When enabled, feed speed parameters will not be displayed.

2.9.7.2.2 Show:

When enabled, feed speed parameters will be displayed.

Example:

Feed speed display will be hidden (*Show* disabled).

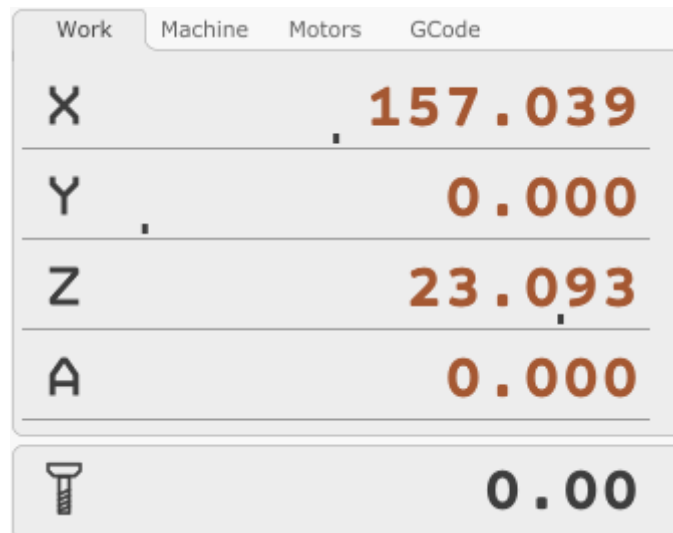

The screenshot shows the PlanetCNC interface with the 'Machine' tab selected. The feed speed display is hidden, showing only the axis labels and their corresponding values. The values are: X: 157.039, Y: 0.000, Z: 23.093, A: 0.000, and a tool icon with 0.00.

Work	Machine	Motors	GCode
X			157.039
Y			0.000
Z			23.093
A			0.000
			0.00

2.9.7.2.3 Size:

Size of feed speed value display.

Example:

Size of feed speed value set to 60.



The screenshot shows the PlanetCNC interface with the 'Machine' tab selected. The feed speed display is visible and has a large font size. The values are: X: 500.00, Y: 0.00, Z: 23.093, A: 0.000, and a tool icon with 0.00.

			500.00
Y			0.00
Z			23.093
A			0.000
			0.00

2.9.7.2.4 Override

Min Feed:

Min percentage value of feed speed set with override. 100% being original feed speed value set with F value (no override set).

Max Feed:

Max percentage value of feed speed set with override. 100% being original feed speed value set with F value (no override set).

Step Feed:

Step increment/decrement of feed speed override value.

Min Traverse:

Min percentage value of traverse speed set with override. 100% being original traverse speed value set with F value (no override set).

Max Traverse:

Max percentage value of traverse speed set with override. 100% being original traverse speed value set with F value (no override set).

Step Traverse:

Step increment/decrement of traverse speed override value.

2.9.7.2.5 Slider

Feed:

When option is enabled, only feed speed override controls will be available.

Traverse:

When option is enabled, only traverse speed override controls will be available.

Both:

When option is enabled, both, feed and traverse speed override controls will be available.

Example:

Both option enabled.



2.9.7.3 Spindle

Group of settings that configure display of spindle speed parameters.

2.9.7.3.1 Hide:

When enabled, spindle speed parameters will not be displayed.

2.9.7.3.2 Show:

When enabled, spindle speed parameters will be displayed.

Example:

Spindle speed display will be hidden (*Show* disabled).

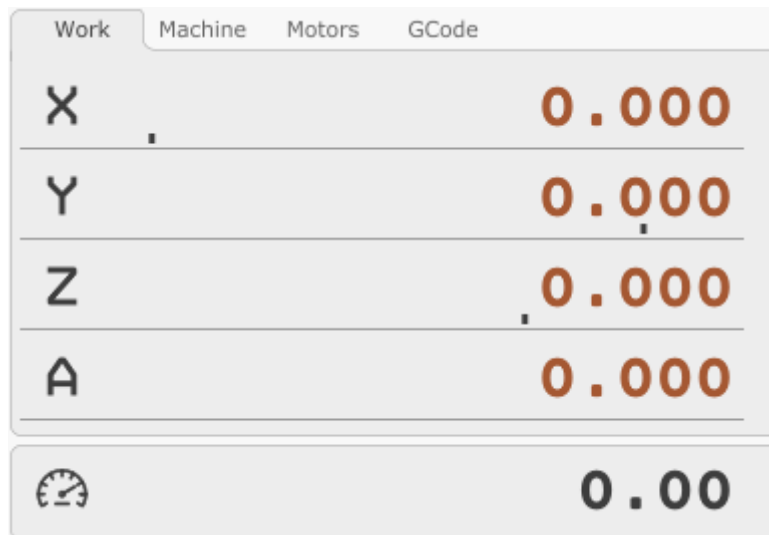

2.9.7.3.3 Size:

Size of feed speed value display.

2.9.7.3.4 Override

Min:

Min percentage value of spindle speed set with override. 100% being original spindle speed value set with S value (no override set).

Max:

Max percentage value of spindle speed set with override. 100% being original spindle speed value

set with S value (no override set).

Step:

Step increment/decrement of spindle speed override value.

2.9.7.3.5 Spindle RPM:

As Set:

Value of spindle speed (RPM) displayed will be the one set in program using the S value, or from *Settings/Program Defaults*.

From Index:

Value of spindle speed (RPM) displayed will be the one that is calculated using Index signal from spindle.

From Encoder:

Value of spindle speed (RPM) displayed will be the one that is calculated using Encoder signals for spindle.

2.9.8 State

State

Colors

Background:

Value:

Label:

GCode

Hide Show

IO

Hide Show

LED Size: mm

Status LEDs:

2.9.8.1 Colors

2.9.8.1.1 Find Match

Based on selected *Main* color, color generator will generate and adjust suitable color shade for *State* segment color parameters.

2.9.8.1.2 Background

Background color of State segment. All state segment tabs will use this color. This color can be set automatically using color generator or using color palette.

2.9.8.1.3 Value

Color of state segment values. Values are basically parameters that are displayed in multiple state segment tabs. This color can be set automatically using color generator or using color palette.

2.9.8.1.4 Label

Color of State segment labels. This color can be set automatically using color generator or using color palette.

Example:

Background color set to blue, value colors set to yellow and label colors set to white.

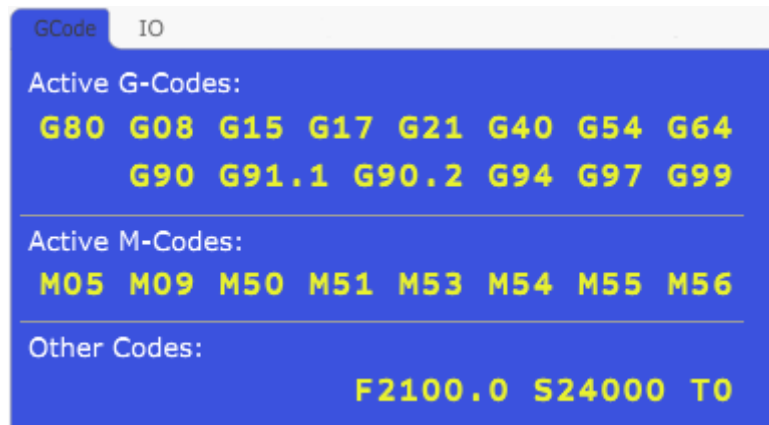

2.9.8.1.5 GCode

Hide:

Disables display of GCode tab.

Show:

Enables display of GCode tab.

2.9.8.1.6 IO

Hide:

Disables display of IO tab.

Show:

Enables display of IO tab.

LED Size:

Size of LED indicators located on state panels.

2.9.8.1.7 Status LEDs

User can add LED indication to bottom toolbar of PlanetCNC TNG main user interface.

You can add LED indicators for Estop, Soft Limits, Hard Limits, Motor Enable, Axis Lock, Error pin, Output header, Input header, Limit input header, Jogging input header, CTRL header.

To create and add a specific LED indicator to toolbar user writes its dedicated short code into Status LEDs input bar.

ES: Creates Estop LED indicator.

SL: Creates Soft Limit LED indicator.

LM: Creates Hard Limits LED indicator.

MT: Creates Motor Enable LED indicator.

AL: Creates Axis Lock LED indicator.

ER: Creates Error pin LED indicator.

On: Creates Output header pin LED indicator. O3 would create indicator for output pin 3.

In: Creates Input header pin LED indicator. I3 would create indicator for input pin 3.

Ln: Creates Limit header pin LED indicator. L3 would create indicator for limit input pin 3.

Jn: Creates Jog header pin LED indicator. J3 would create indicator for jogging input pin 3.

Cn: Creates CTRL header pin LED indicator. C3 would create indicator for CTRL pin 3.

Example:

We would like to create LED indicator for Input pin 1 and Output pin 3.

In such case we write O3 and I1 into input bar:



Status LEDs:

Indicators are created in the bottom left corner:



2.9.9 Jog

The screenshot shows the 'Jog' configuration window. It is divided into two main sections: 'Colors' and 'Properties'.
The 'Colors' section contains a 'Find Match' button and four color selection fields: 'Background', 'Value', 'Button', and 'Arrows'. Each field has a star icon to its right.
The 'Properties' section contains three radio buttons: 'Hide', 'Show' (which is selected), and 'Fixed'. Below these is a 'Size' field with the value '42' and a '- + pt' control. At the bottom, there are two checked radio buttons: 'XY Cross' and 'UV Cross'.

2.9.9.1 Colors

2.9.9.1.1 Find Match

Based on selected *Main* color, color generator will generate and adjust suitable color shade for *Jog* segment color parameters.

2.9.9.1.2 Background

Background color of *Jog* segment. This color can be set automatically using color generator or using color palette.

2.9.9.1.3 Value

Color of *Jog* segment value. Value is jog speed. This color can be set automatically using color generator or using color palette.

2.9.9.1.4 Button

Color of jog segment button. This color can be set automatically using color generator or using color palette.

2.9.9.1.5 Arrows

Color of jog segment jogging arrow keys. This color can be set automatically using color generator or using color palette.

2.9.9.2 Properties

Hide:

Disables display of Jog segment.

Example:

Jog segment set to *Hidden*



Show:

Enables display of Jog segment. Jogging keys panel will appear when user clicks Jog button. When user clicks on any other part than jogging panel, jogging panel will disappear.

Example:

Jog segment set to *Show*, however, *Fixed* or *XY/UV Cross* options are not enabled



Fixed:

Jog arrow keys panel is fixed and it will be permanently displayed.

Size:

Inserted value sets size of jog speed display.

XY Cross:

Cross formation of XY axis jogging keys.

UV Cross:

Cross formation of UV axis jogging keys.

Example:

Jog segment set to *Fixed*, neither of the XY or UV Cross options is enabled

**Example:**

Background set to yellow, *value* set to black, *button* set to blue, *arrows* set to green.

Jogging keys are set to *Fixed* and using *XY Cross* layout.



2.9.10 3D

2.9.10.1 Colors

2.9.10.1.1 Find Match

Based on selected *Main* color, color generator will generate and adjust suitable color shades for 3D segment color parameters.

Colors

Find Match

Background: ☆

Axes: ☆

Grid: ☆

Limits: ☆

Extents: ☆

Extents Feed: ☆

Gauges: ☆

Traverse: ☆

Line: ☆

Arc: ☆

Sync: ☆

Probe: ☆

Selected: ☆

Hover: ☆

Completed: ☆

History: ☆

Position: ☆

Simulation: ☆

G28: ☆

G30: ☆

Wire: ☆

Wire Skin: ☆

Background

Axes

Grid

Limits

Extents

Extents Feed

Gauges

Traverse

Line

Arc

Sync

Probe

Selected

Hover

Completed

History

Position

Simulation

G28

G30

Wire

Wire Skin

2.9.10.2 Properties

Properties

Alpha: - + Traverse: - +

Thickness: - +

Resolution: - + mm

Refresh: - + ms Fast

Hide Sub Level: - + Subs MCode

Tool Size: - + Diameter: - +

Show Offset Length Diameter

History Size: - +

2.9.10.2.1 Alpha & Traverse

This parameter will affect displayed toolpath in such way, that toolpath at highest Z level will be less transparent than the one at the lowest Z level. This way user gets better sense of depth of displayed toolpath. This also helps with better overall presentation of toolpath. With **Traverse** value you can set the same for traverse toolpath moves.

Example:

Displayed toolpath with *Alpha* parameter set at 1:

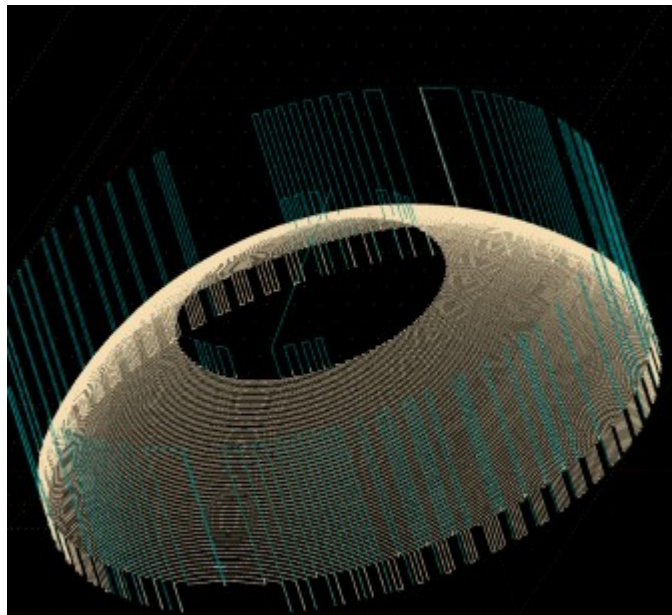

Displayed toolpath with *Alpha* parameter set at 0.1:

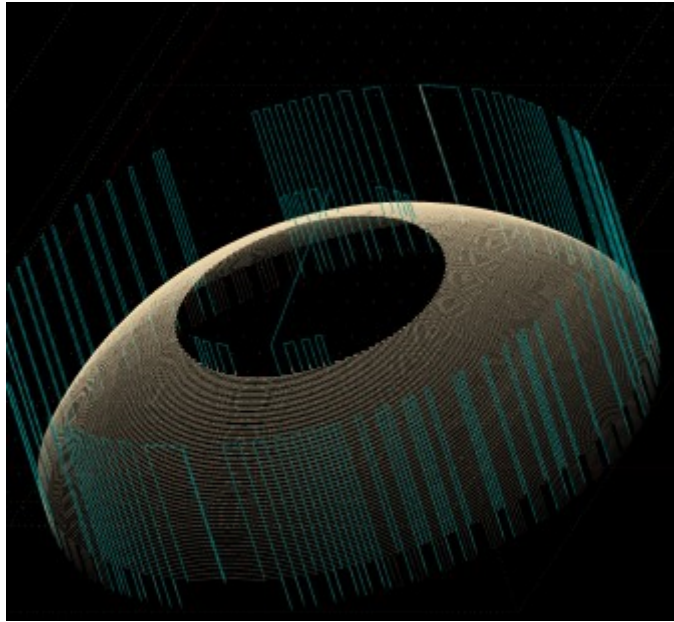

2.9.10.2.2 Thickness

With this parameter you can set thickness of displayed toolpath.

Example:

Displayed toolpath with *Thickness* parameter set at 1:

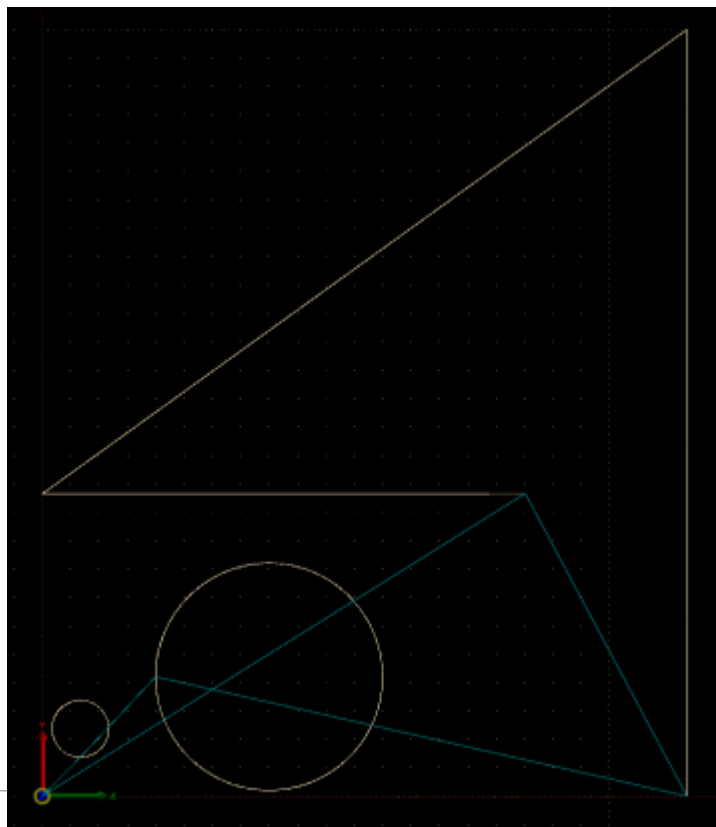

Displayed toolpath with *Thickness* parameter set at 5:

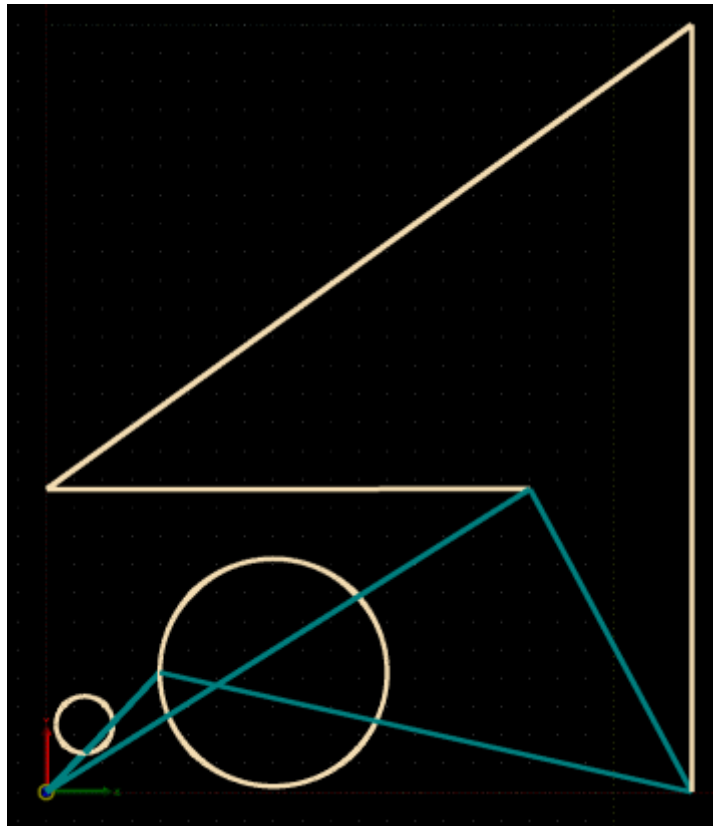

2.9.10.2.3 Resolution:

This parameter sets tolerance for which displayed toolpath is allowed to deviate from actual toolpath. Units for this parameters are millimeters.

Please note that this parameter will only affect the displayed toolpath.

Example:

Display resolution set to: 0.01mm

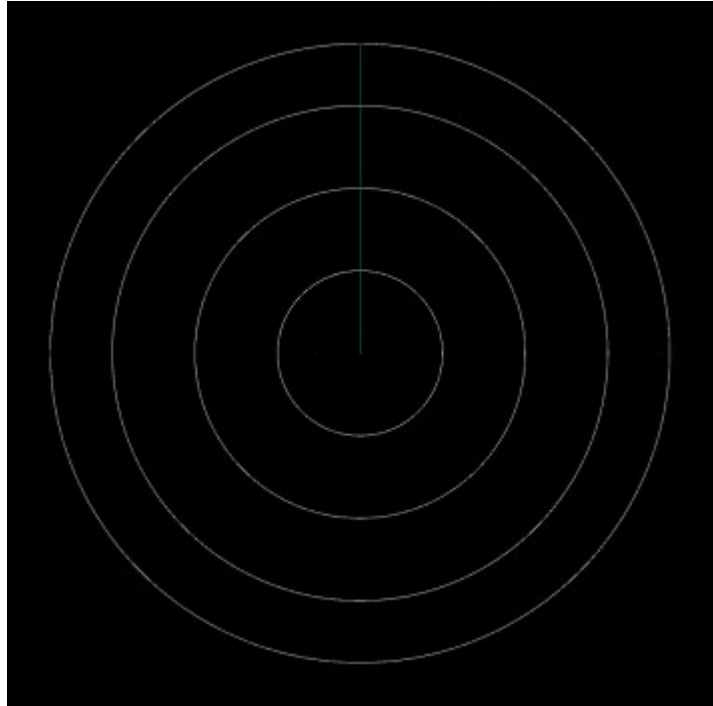

Display resolution set to: 0.8mm

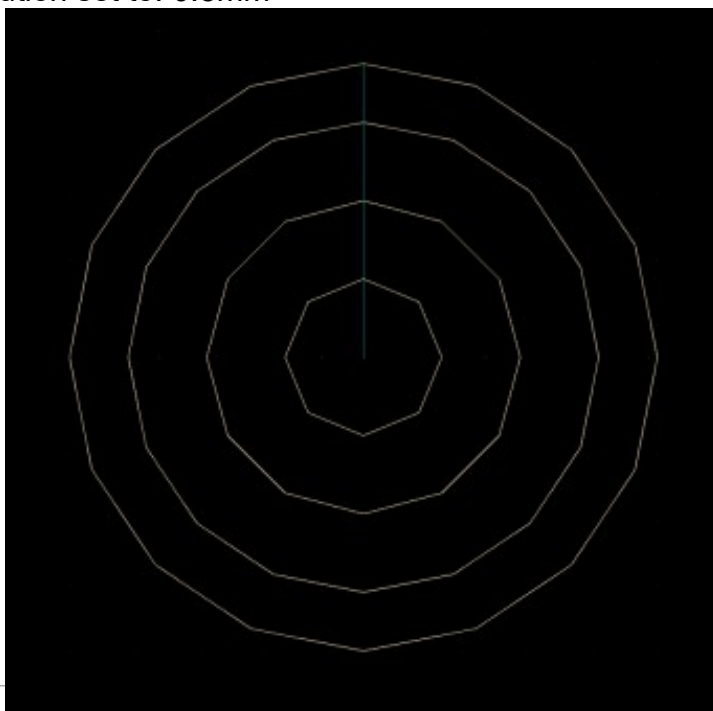

2.9.10.2.4 Refresh

This parameter sets 3D display refresh time. Value inserted is time in milliseconds, after which 3D display of PlanetCNC TNG will refresh.

Fast:

2.9.10.2.5 Hide Sub Level

Gcode programs can include sub-procedures, external sub-procedure files as also g-codes using scripted behaviour. With this setting parameter user can enable/disable display of sub-procedure, external sub-procedure or scripted g-code toolpaths.

Hide Sub Level value represents the sub level of sub-routine from which on toolpath will not be displayed. So if we use a 4 sub level g-code program and inserted value is 2, this means that toolpath for levels 3-5 will not be displayed.

Example:

Gcode program below uses o-word sub-procedures. If we look closer at the g-code we can see that this is a 4 level sub procedure g-code program, with main program being level 0.

```
1: %
2: G00 Z30
3: G00 X0 Y0
4: G00 Z0
5: o100 call
6: G01 X0
7:
8: o100 sub
9:   G03 I-10 J-10
10:  G00 X-10 Y-10
11:  G00 X0 Y0
12:  o200 call
13: o100 endsub
14:
15: o200 sub
16:   G01 Y50
17:   G03 I-10 J10
18:   G91
19:   G00 X-10 Y10
20:   G90
21:   G00 Y50 X0
22:   O300 call
23: o200 endsub
24:
25: o300 sub
26:   G01 X50
27:   G03 I10 J10
28:   G91
29:   G00 X10 Y10
30:   G90
31:   G00 X50 Y50
32:   o400 call
33: o300 endsub
34:
35: o400 sub
36:   G01 Y0
37:   G03 I10 J-10
38:   G91
39:   G00 X10 Y-10
40:   G90
41:   G00 X50 Y0
42: o400 endsub
43:
44: %
```

Toolpath for program above, displayed in its entirety (each sub level is represented with circle):

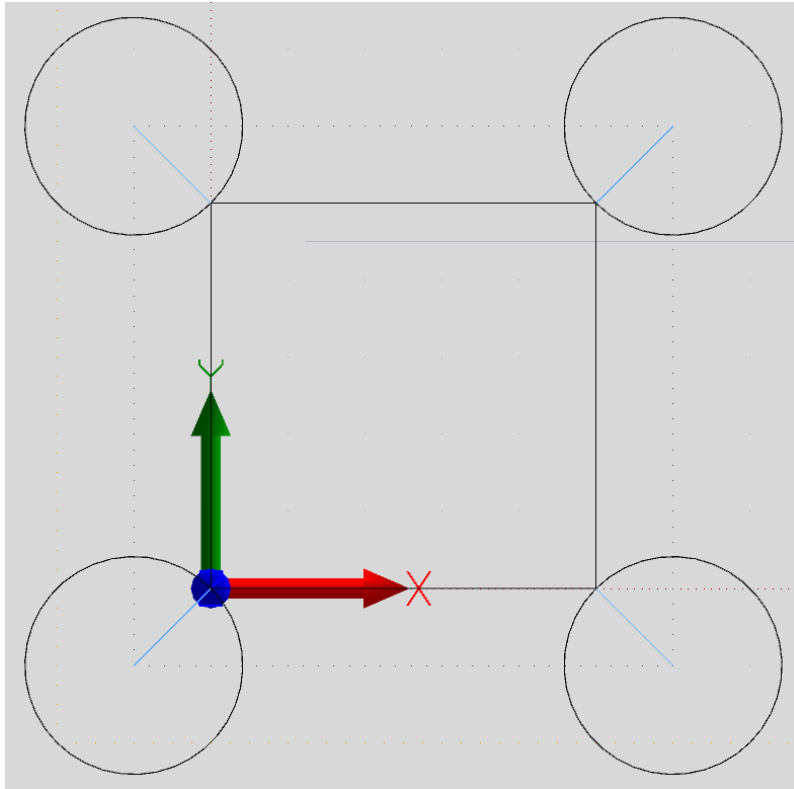

If we set *Hide Sub Level* value to 3, then toolpath for sub levels 3 and further, will not be displayed (only sub procedures levels 1 and 2 are displayed):

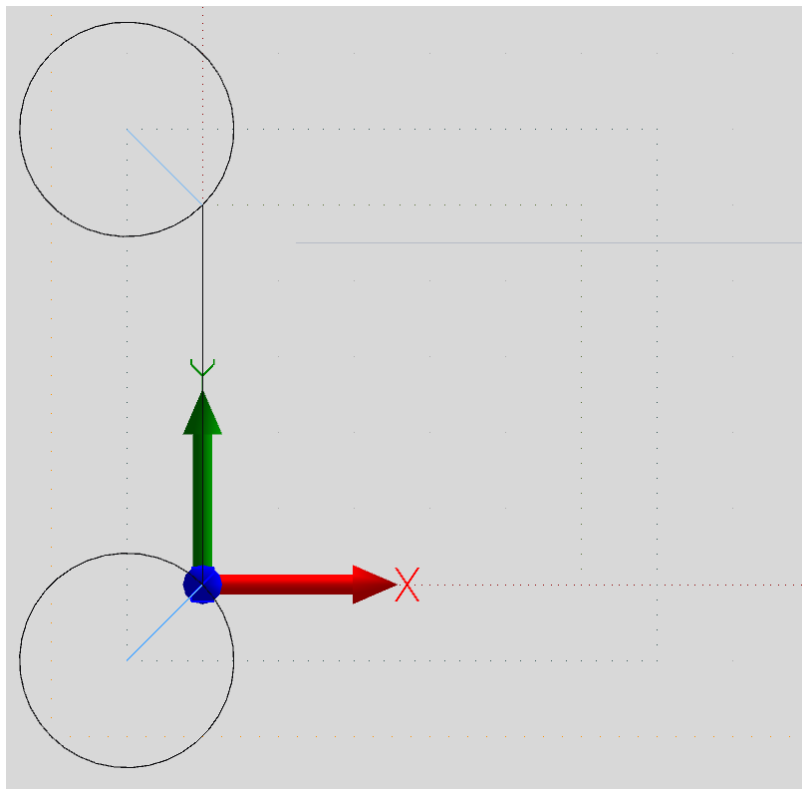

2.9.10.2.6 Subs

Sub procedures can also be standalone gcode files which are called from main program. This option disables display of external file sub-procedure toolpath.

Example:

Gcode program below calls external standalone sub-procedures:

```
1 %  
2 G00 Z30|  
3 G00 X0 Y0  
4 G00 Z0  
5 G00 X-5 Y-5  
6 G01 X40  
7 G01 Y10  
8 G01 X-5  
9 G01 Y-5  
10 G00 X0 Y0  
11 o<num1> call  
12 G00 Y-5  
13 G01 X10  
14 G00 Y0  
15 o<num2> call  
16 G00 Y-5  
17 G01 X20  
18 G00 Y0  
19 o<num3> call  
20 G00 Y-5  
21 G01 X30  
22 G00 Y0  
23 o<num4> call  
24 %
```

Toolpath for program above, displayed in its entirety (each sub procedure is represented with a number):

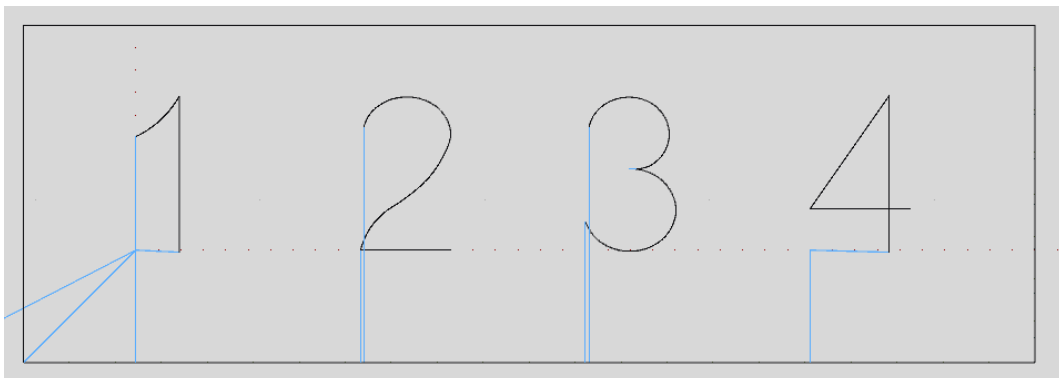

If we enable *Subs* option, then toolpath for standalone sub procedures will not be displayed:

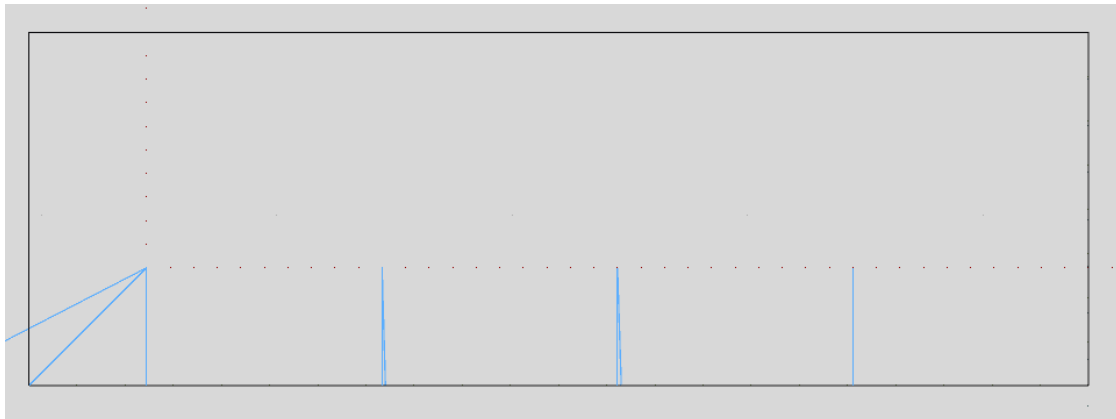

2.9.10.2.7 Mcode

This option will enable/disable display of M gcode script code.

Example:

If your machine uses automatic tool change, your M6 script uses script code for correct motion behaviour, output pin manipulation etc.... with Mcode option enabled you can hide all toolpath related to tool change procedure (M6 script code).

2.9.10.2.8 Tool Size & Diameter:

Yellow cone represents the tool position. You can change its length and size with *Tool Size* and *Diameter* parameters.

Example:

Tool size at value 10:

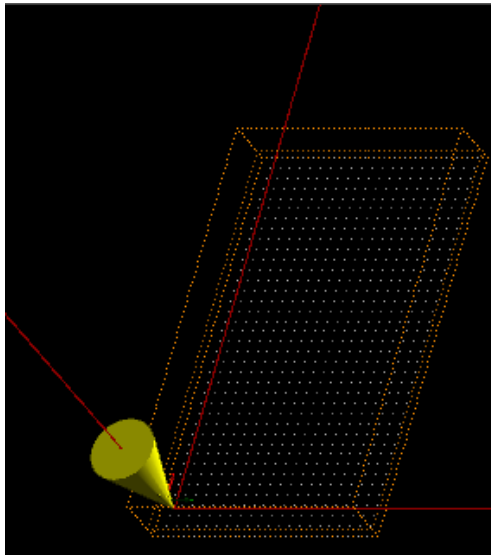

Tool size at value 15:

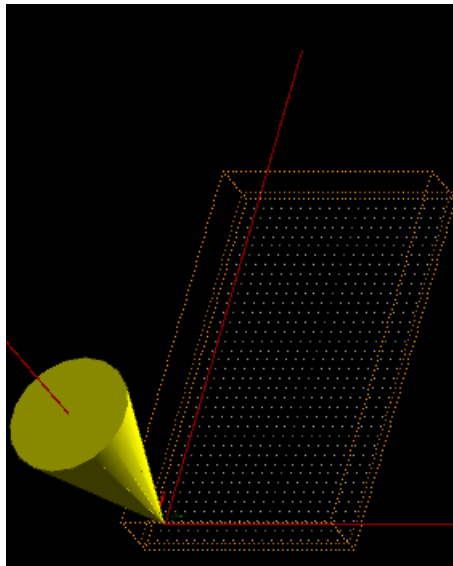

2.9.10.2.9 Show: Offset, Length, Diameter

With these options enabled, displayed tool will mimic the offset, length and diameter of active tool from tool table.

Example:

Selected active tool from tool change has offset Z set to 50mm and diameter of 2mm.

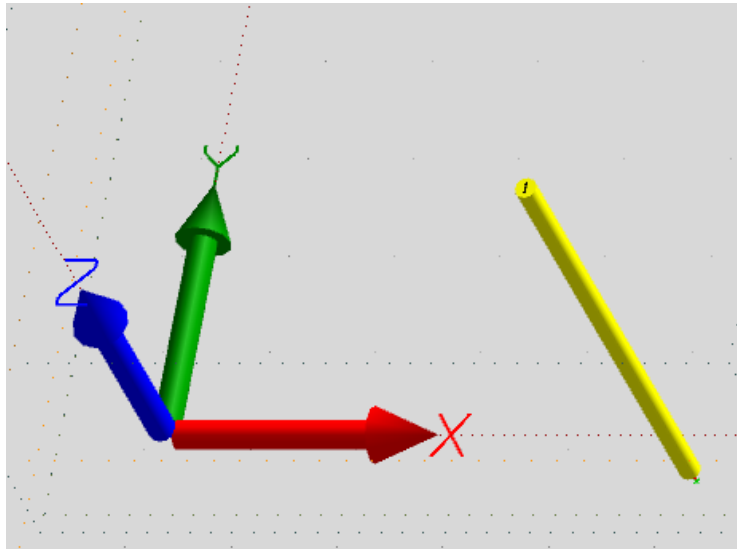

2.9.10.2.10 History Size

Value inserted is length of tool trace which software will still display as *Toolpath History*.

2.9.10.3 User Interface/Geometry

Parameters under 'Geometry' tab allow customization of 3D axis and tool display to fit most types of machines.

Presets for most common machine types are available for your convenience.

NOTE: These parameters do not have any effect on axis motion itself, only on axis 3D display.

Geometry

Select Preset:

Rotate & Mirror X: Y: Z:

Axis System: Link

XYZ

Axis: X Y Z

Origin: X: Y: Z:

Orientation: X: Y: Z:

Rotation: A B C

Rotation Offset: X: Y: Z:

Rotation Interpolation: Enable

ABC

Axis: A B C

Origin: X: Y: Z:

Orientation: X: Y: Z:

UVW

Axis: U V W

Origin: X: Y: Z:

Orientation: X: Y: Z:

You can choose between 4 presets: *Normal*, *Mirror*, *Lathe* and *Foam Cutter*.

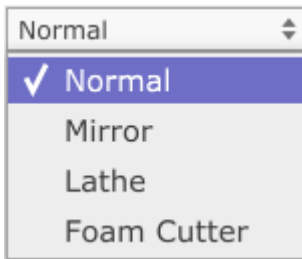

Each preset automatically adjusts *Rotate&Mirror*, *Axis* and *Orientation* parameters so that 3D axis and tool display suit to corresponded machine type(E.g.: Lathe and Foam Cutter).

2.9.10.3.1 Rotate & Mirror:

Rotate:

Rotate parameter will rotate 3D display of coordinate system. Rotate parameter units are degrees. Rotation will be applied over selected axis in clockwise direction.

Rotation in all axes is set to 0:

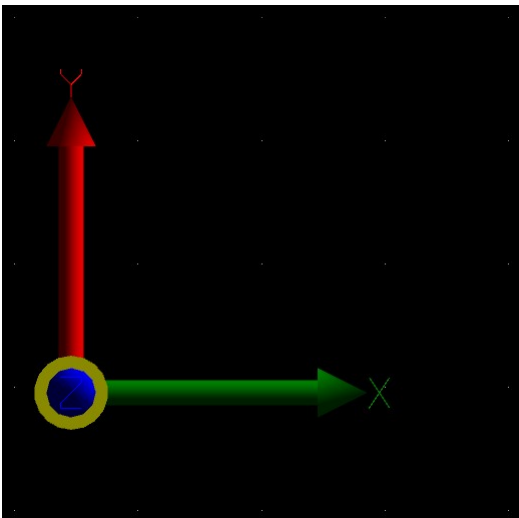

Rotation over Z axis set to 90 degrees:

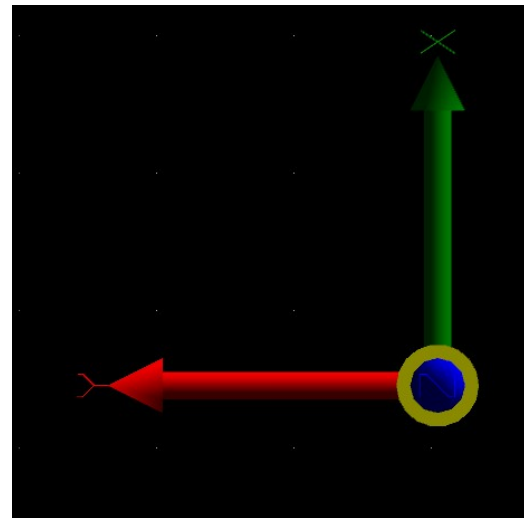

Mirror:

Enabled radio button enables mirror option for selected axis. Displayed axis of 3D coordinate system will be mirrored.

Mirror options for all axes are disabled:

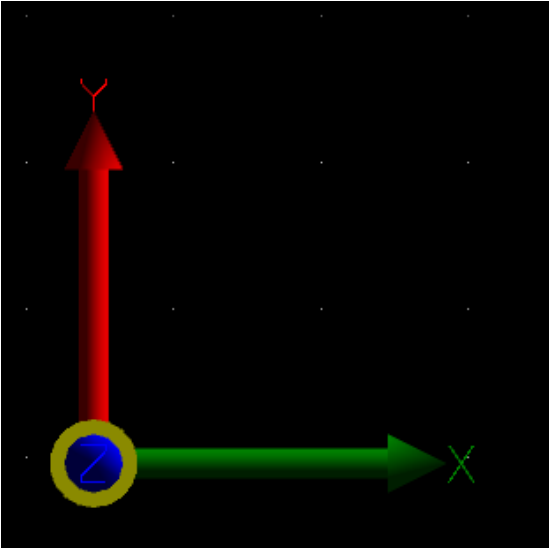

Mirror options for X and Y axes enabled:

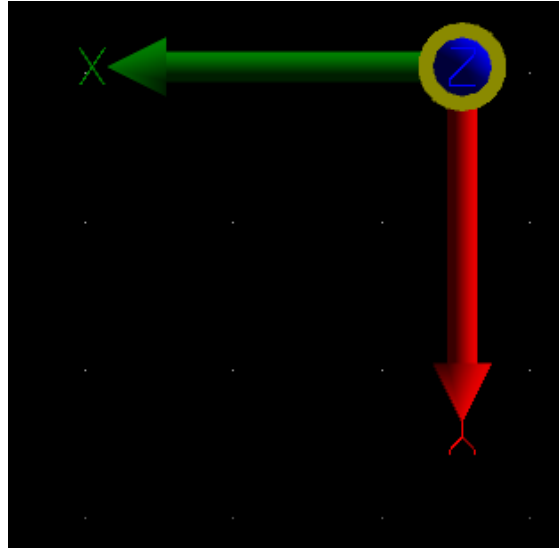

2.9.10.3.2 Axis System:

When enabled, axis system tools will be “connected” with displayed line (E.g.: hot wire of foam cutter machine $XY \rightarrow UV$).

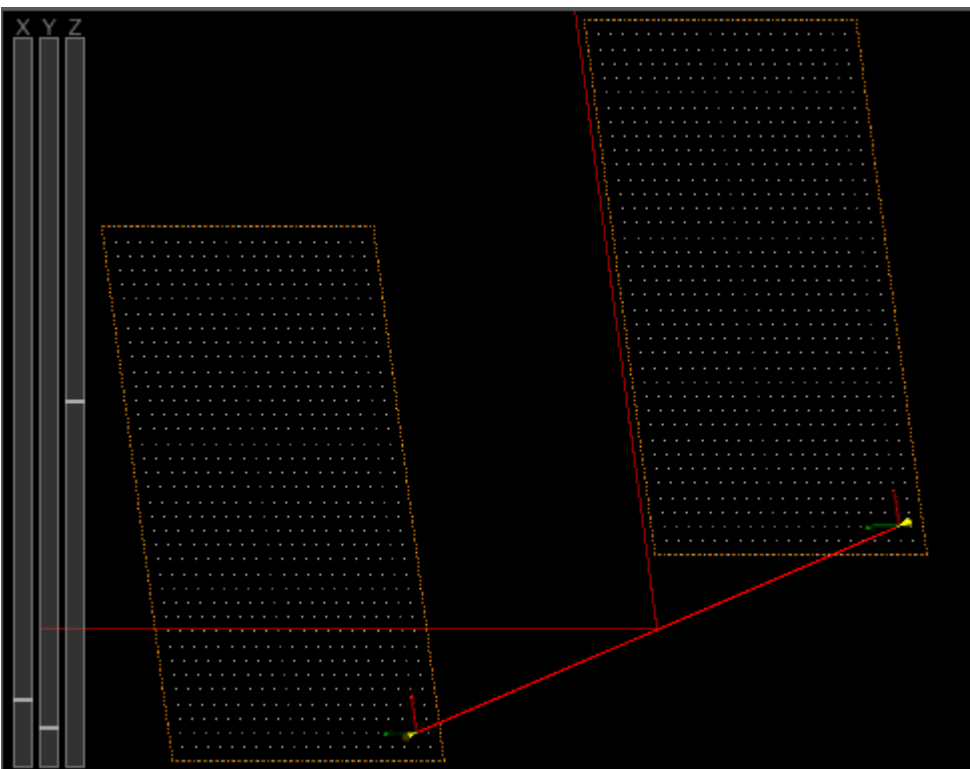

2.9.10.3.3 XYZ:

Display settings for XYZ axes of 3D coordinate system. You can enable or disable 3D display of selected axis. Set origin of axes and tool orientation.

Axis:

Radio button enables or disables display of selected axis of 3D coordinate system.

All axes display is enabled:

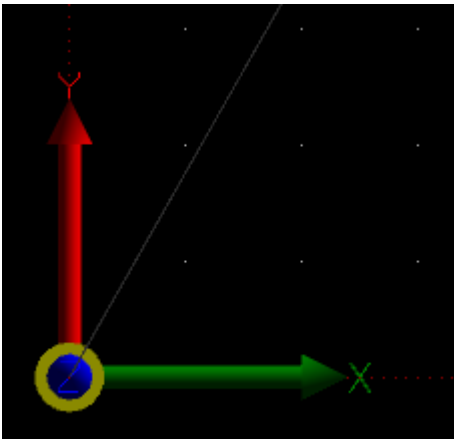

X axis display is disabled:

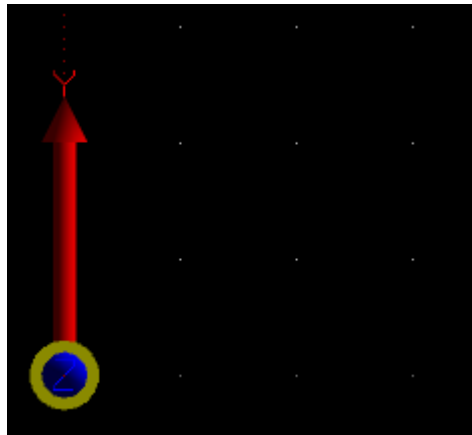

2.9.10.3.4 Origin

Sets offset of displayed axis origin for selected axis.

Origin parameter set to 0,0:

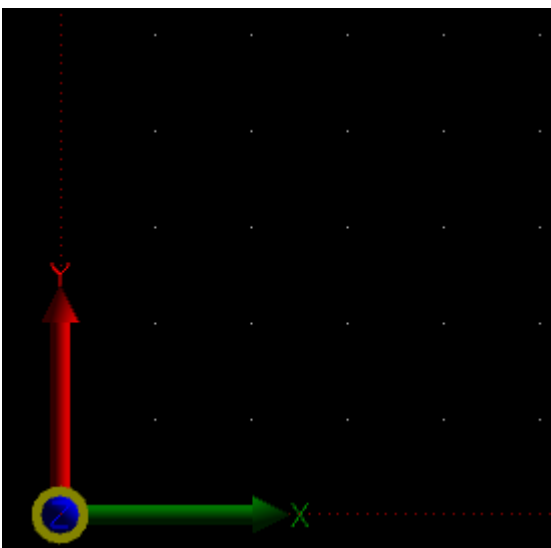

Origin parameter set to -20,-20:

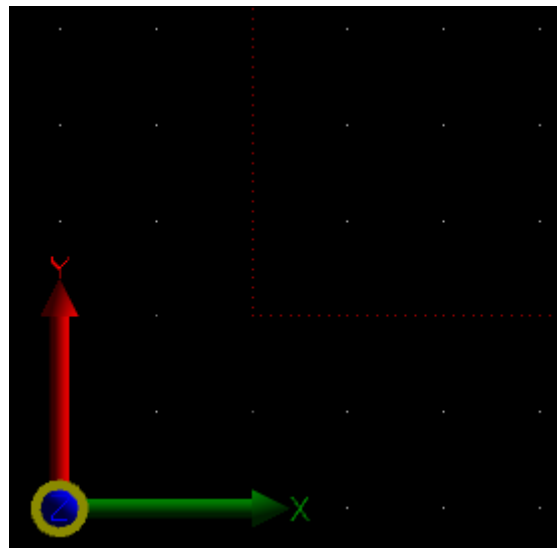

2.9.10.3.5 Orientation

Sets orientation of 3D tool. Orientation parameter unit are degrees. Orientation of 3D tool display will be applied for selected axis in counter clockwise direction.

You can change the 3D tool orientation so that it suits your machine, E.g.: Lathe, where tool is mounted in horizontal direction.

Orientation X set to: 0,0,0

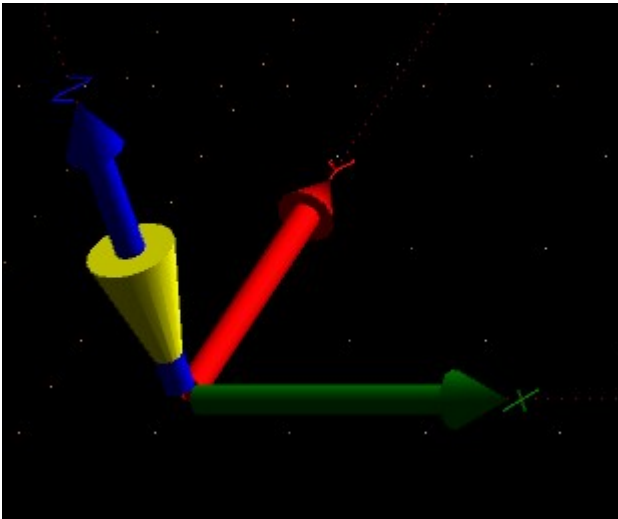

Orientation X set to: 90,0,0

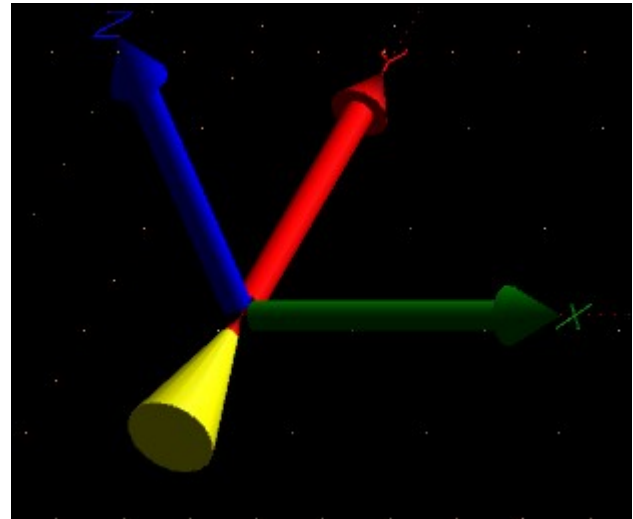

2.9.10.3.6 Rotation

These settings are used to assist visualization of A,B,C rotational axes.

By enabling it for specific rotational axis, displayed toolpath and tool position will include rotations.

A: Displayed toolpath and tool position will include rotations for A axis.

B: Displayed toolpath and tool position will include rotations for B axis.

C: Displayed toolpath and tool position will include rotations for C axis.

Example:

Displayed toolpath of Gcode program using A axis, with Rotation option disabled for A axis:

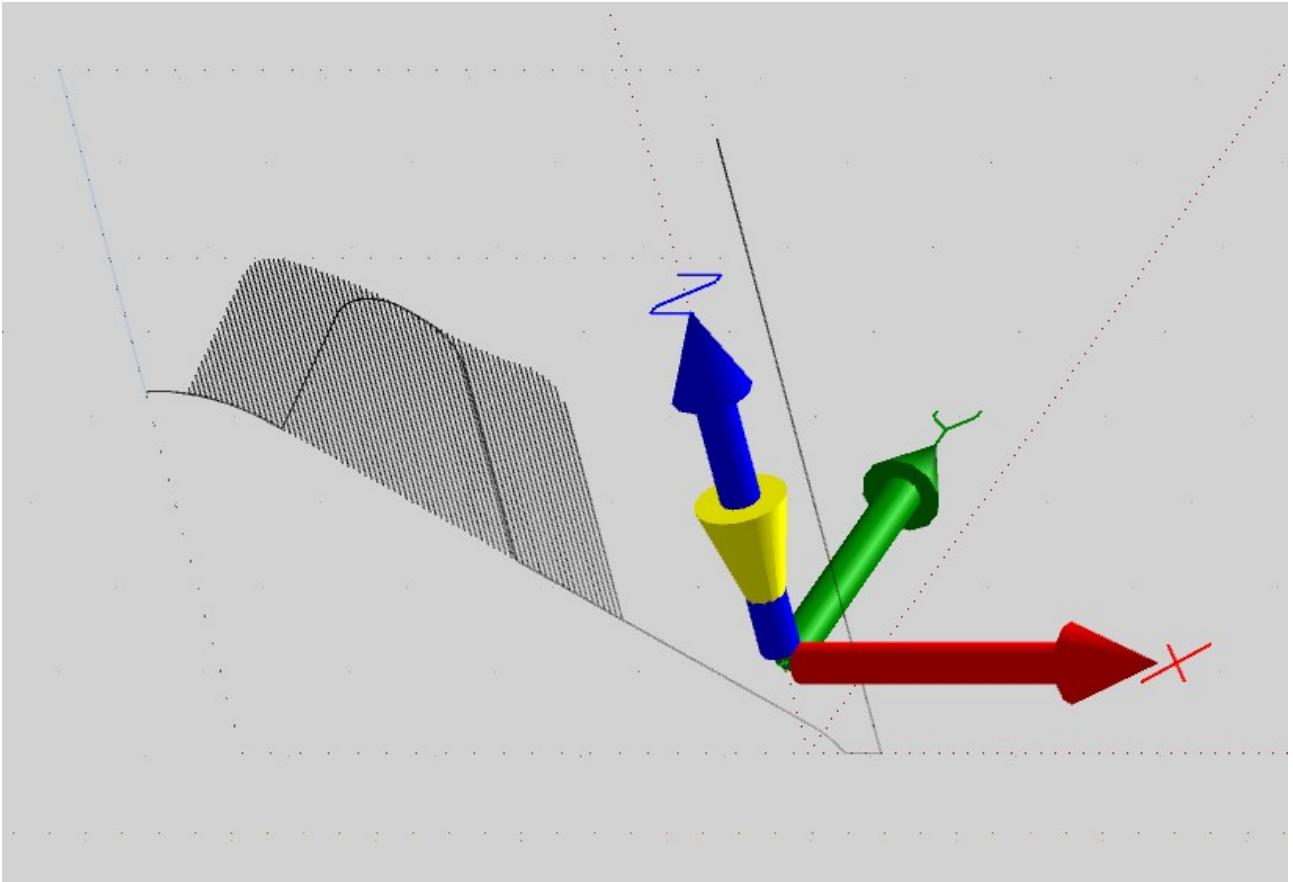

Displayed toolpath of Gcode program using A axis, with Rotation option enabled for A axis:

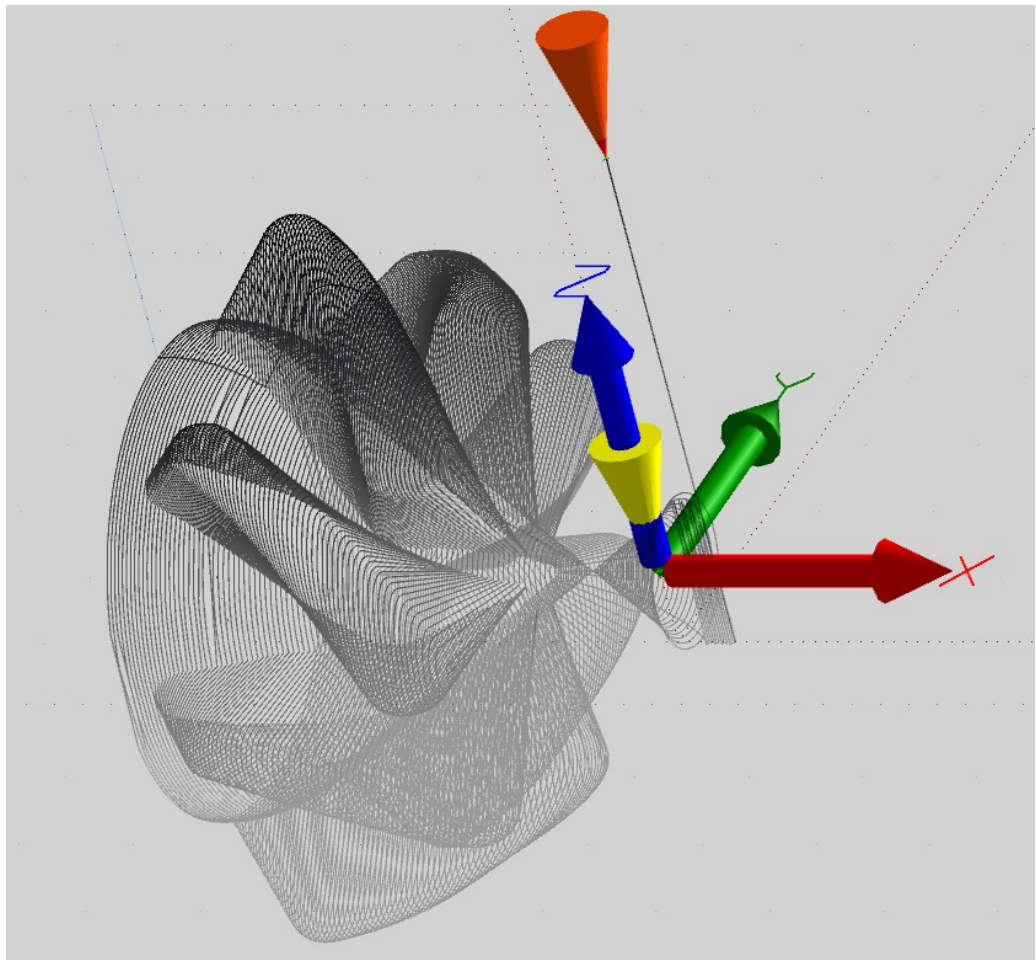

2.9.10.3.7 Rotation Offset

In case that working zero is not in the centre of rotation of rotational axis, you can set rotation offset.

2.9.10.3.8 Rotation Interpolation

To increase level of displayed details of rotation toolpath you enable this option.

2.9.10.4 *ABC:*

Display settings for ABC axes of 3D coordinate system. You can enable or disable 3D display of selected axis. Set origin of axes and tool orientation.

2.9.10.4.1 *Axis*

Radio button enables or disables display of selected axis of 3D coordinate system.

2.9.10.4.2 *Origin*

Sets offset of displayed axis origin for selected axis.

2.9.10.4.3 *Orientation*

Sets display orientation of 3D tool. Orientation parameter units are degrees. Orientation of 3D tool display will be applied for selected axis in counter clockwise direction.

2.9.10.5 *UVW:*

Display settings for UVW axes of 3D coordinate system. You can enable or disable 3D display of selected axis. Set origin of axes and tool orientation.

2.9.10.5.1 *Axis*

Radio button enables or disables display of selected axis of 3D coordinate system.

2.9.10.5.2 *Origin*

Sets offset of displayed axis origin for selected axis.

2.9.10.5.3 *Orientation*

Sets display orientation of 3D tool. Orientation parameter units are degrees. Orientation of 3D tool display will be applied for selected axis in counter clockwise direction.

2.9.11 Gcode

GCode

Colors

Background: ☆

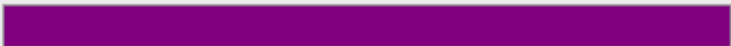
Line No:  ☆

G Word:  ☆

M Word:  ☆

Axis Word:  ☆

IJKR Word:  ☆

N Word:  ☆

O Word:  ☆

S Word:  ☆

T Word:  ☆

F Word:  ☆

Numbers:  ☆

Param:  ☆

Expression:  ☆

Comment:  ☆

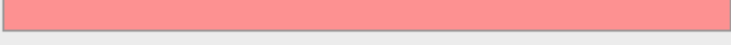
Script:  ☆

Other:  ☆

2.9.11.1 Colors

You can customize colors of G-Code program lines displayed in G-Code window.

You can set colors of g-code words such as G words, M words, MDI etc...

2.9.11.1.1 Find Match

Based on selected *Main* color, color generator will generate and adjust suitable color shade for *Gcode* segment color parameters.

You can set colors for:

Background

Line No

G Word

M word

Axis Words

IJKR Words

N Word

O Word

S Word

T Word

F Word

Numbers

Param

Expression

Comment

Script

Other

2.9.11.2 Properties

Properties

Text Size: - + pt

MDI

MDI Text Size: - + pt

MDI Background: ☆

MDI Focus: ☆

MDI Text: ☆

History: Enable

2.9.11.2.1 Text Size

Size of Gcode text.

Example:

Text size set to 18:

```
16: G1 Z1. F1800.  
17: G2 X141.083 Y79.001 Z0.895 I-0.132 J-0.29  
18: G1 X141.418 Y78.294 Z0.53  
19: G2 X141.266 Y77.869 Z0.296 I-0.289 J-0.13  
20: G1 X134.876 Y74.845 Z-3.  
21: X133.15 Y74.029 F1800.  
22: G2 X132.724 Y74.181 I-0.137 J0.289  
23: G1 X132.39 Y74.889  
24: G2 X132.542 Y75.314 I0.289 J0.137  
25: G1 X140.658 Y79.153  
26: G2 X141.083 Y79.001 I0.137 J-0.289  
27: G1 X141.418 Y78.294  
28: G2 X141.266 Y77.869 I-0.289 J-0.137  
29: G1 X134.876 Y74.845  
30: G3 X133.377 Y72.351 I1.122 J-2.371
```

Text size set to 30:

```
16: G1 Z1. F1800.  
17: G2 X141.083 Y79.001 Z0.895 I-0.132 J-0.291  
18: G1 X141.418 Y78.294 Z0.53  
19: G2 X141.266 Y77.869 Z0.296 I-0.289 J-0.137  
20: G1 X134.876 Y74.845 Z-3.  
21: X133.15 Y74.029 F1800.  
22: G2 X132.724 Y74.181 I-0.137 J0.289  
23: G1 X132.39 Y74.889  
24: G2 X132.542 Y75.314 I0.289 J0.137  
25: G1 X140.658 Y79.153  
26: G2 X141.083 Y79.001 I0.137 J-0.289  
27: G1 X141.418 Y78.294  
28: G2 X141.266 Y77.869 I-0.289 J-0.137  
29: G1 X134.876 Y74.845  
30: G3 X133.377 Y72.351 I1.122 J-2.371
```

2.9.11.3 MDI

2.9.11.3.1 MDI Text Size

Size of MDI text.

Example:

MDI text size set to 25:

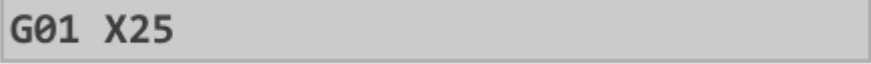

G01 X25

MDI text size set to 45:



G01 X25

2.9.11.3.2 MDI Background

Background color of MDI window when in idle mode. This color can be set automatically using color generator or using color palette.

Example:

Color of MDI background set to orange:

A horizontal rectangular bar with an orange background. The text "G01 X25" is displayed in black on the left side of the bar.

G01 X25

2.9.11.3.3 MDI Focus

Background color of MDI window when in focused mode. This color can be set automatically using color generator or using color palette.

Example:

Color of MDI background set to green:

A horizontal rectangular bar with a green background. The text "G01 X25" is displayed in black on the left side of the bar.

G01 X25

2.9.11.3.4 MDI Text

Color of MDI text. This color can be set automatically using color generator or using color palette.

Example:

Color of MDI text set to blue

A horizontal rectangular bar with a grey background. The text "M3 S8000" is displayed in blue on the left side of the bar.

M3 S8000

2.9.11.3.5 History

When enabled, software tracks history of previously used Menu (File, Program, Machine etc...) items such as Open, Close, Shift, Scale, EStop etc...

You can see list of commands used in chronological order if you focus MDI bar and then press Up keyboard arrow key.

You are able to navigate through the command history list with Up or Down keyboard arrow keys.

With Enter keyboard key you select command from the history list and again with Enter keyboard key you execute it.

Example:

With *History* option disabled:



A screenshot of a CNC control interface showing the MDI bar. The bar contains three lines of G-code: M3 S8000, G00 Z100, and G01 X10. The first line is highlighted in black, indicating it is the current command.

```
M3 S8000
G00 Z100
G01 X10
```

With *History* option enabled:

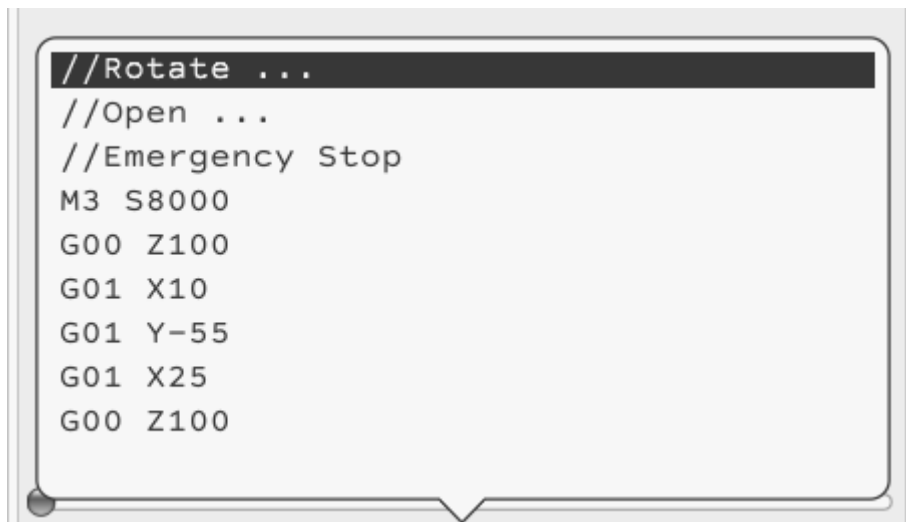

A screenshot of a CNC control interface showing the MDI bar. The bar contains a list of commands in chronological order: //Rotate ..., //Open ..., //Emergency Stop, M3 S8000, G00 Z100, G01 X10, G01 Y-55, G01 X25, and G00 Z100. The first line is highlighted in black, indicating it is the current command.

```
//Rotate ...
//Open ...
//Emergency Stop
M3 S8000
G00 Z100
G01 X10
G01 Y-55
G01 X25
G00 Z100
```

2.9.12 Utilities

The screenshot shows the 'Utilities' configuration panel. It is divided into three sections: 'Colors', 'Panels', and 'Background'. The 'Colors' section has a 'Find Match' button and three color selection fields: 'Background' (white), 'Text' (black), and 'Button' (black). Each field has a star icon to its right. The 'Panels' section has three options: 'Edit: ✓ Embed', 'Camera: ✓ Embed', and 'Log: ✓ Embed'.

2.9.12.1 Colors

2.9.12.1.1 Find Match

Based on selected *Main* color, color generator will generate and adjust suitable color shade for *Utilities* segment color parameters.

2.9.12.1.2 Background

Background color of Utilities segment. This color will be used for all Utilities panels. This color can be set automatically using color generator or using color palette.

Example:

Background color of Output panel set to rose color.

**2.9.12.1.3 Text**

Color of *Utilities* text. This color will be used for all Utilities panels. This color can be set automatically using color generator or using color palette.

Example:

Background color of Output panel set to white color.

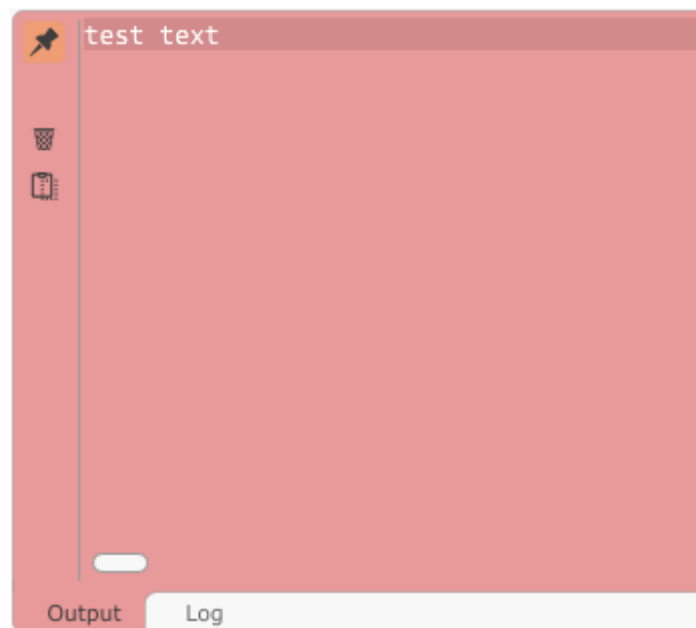

2.9.12.1.4 Button

Utilities button colors. This color will be used for all Utilities panels. These colors can be set automatically using color generator or using color palette.

Example:

Button color set to yellow color.

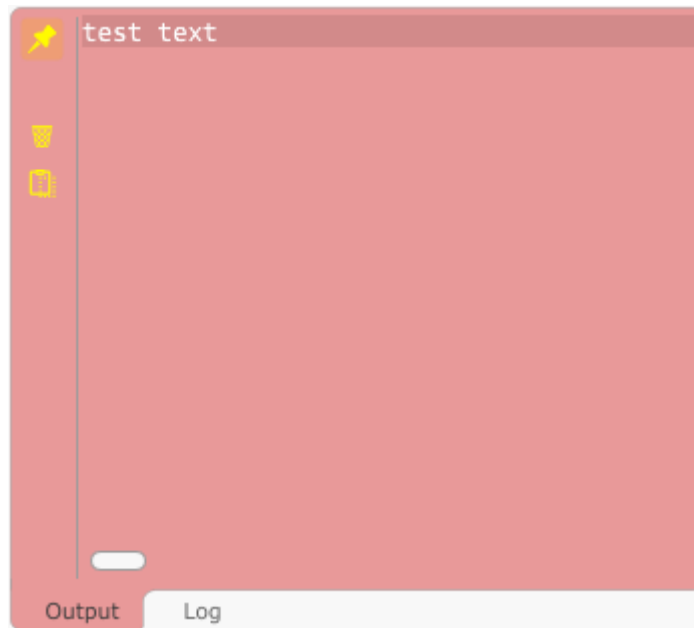

2.9.12.2 Panels

2.9.12.2.1 Edit

When enabled, *Edit* panel will be permanently embedded under *Utilities* segment.

2.9.12.2.2 Camera

When enabled, *Camera* panel will be permanently embedded under *Utilities* segment.

2.9.12.2.3 Log

When enabled, *Log* panel will be permanently embedded under *Utilities* segment.

Example:

All utilities panels permanently embedded. User can use tabs in order to select desired panel.



2.9.13 Shortcuts

Use of shortcuts can greatly reduce time when configuring machine for certain job and overall helps with more fluent work with PlanetCNC TNG.

You can set keyboard shortcuts for program features included in *File*, *View*, *Program*, *Machine* and *Help* menus. *Jogging* set of shortcuts is also available.

With PlanetCNC TNG you can map your controller digital inputs to manipulate desired features, such as work positions etc..

Shortcuts				
Action	Code	MDI	Pin	
File				
Close				↕
Open ...				↕
Open Last File				↕
Open File				↕
Open Code				↕
Import G-Code ...				↕
Import DXF ...				↕
Import PLT, HPGL ...				↕
Import Gerber ...				↕
Import NC Drill ...				↕
Import CSV ...				↕
Import Image ...				↕
Import Python Script ...				↕
Generate				
Export G-Code ...				↕
Export DXF ...				↕
Export CSV ...				↕
Export STL ...				↕
Run Python Script ...				↕
Settings ...	S			↕
Import Settings ...				↕
Export Settings ...				↕
Import Profile ...				↕
Export Profile ...				↕
Exit				↕
View				
Top View	F1			↕
Side View	F2			↕
Front View	F3			↕
Perspective View	F4			↕
Zoom In	F5			↕
Zoom Out	F6			↕
Zoom Position	F7			↕

You can set **Code**, **MDI** and **Pin** shortcuts for specific **Action**.

2.9.13.1 Action

Here are listed all features that are included in *File*, *View*, *Program*, *Machine* and *Help* menus. Actions are organized in chapters: **File**, **View**, **Program**, **Machine** and **Help**

2.9.13.2 Code

Here you can set unique code for each selected Action.

This can be either one single code (for example keyboard key for letter S as shortcut code for Action: Settings; settings dialogue will open when we press keyboard key S) or combination of multiple keyboard keys (for example combinations of keyboard keys Shift + T).

Example:

Let say we want to create code for showing *Machine/Tools/Edit Tool Table* dialog. Find *Edit Tool Table* in *Machine* section of *Action* chapter and enter desired MDI shortcode: E.g.: Shift + T



2.9.13.3 MDI

Sets unique MDI code for specific Action.

Example:

Let say we want to create MDI shortcode for showing *Log* panel. Find *Show Log* in *Help* section of *Action* chapter and enter desired MDI shortcode: E.g.: *Log*



When you try to execute desired MDI code from MDI window you need to insert symbol “/” before MDI code and click enter:



2.9.13.4 Pin

You can map your controllers digital input to activate specific Action.

Example:

Let say we want to map digital input 1 of controller to action Start.

Find Start in Machine section of Action chapter and under pin select Input 1 from the drop down menu.

When digital input is active, action mapped to that input will execute.



Controllers digital input 1 is set to execute Start action:

Machine		
Emergency Stop	Escape	↕
Start	Input 1	↕
Stop		↕

2.9.14 Motors

Under this group of settings you can configure settings important for compatibility with stepper/servo drives, enable signal configuration, controller axis output configuration, motor speeds and accelerations, axis backlash value, limitations of motors as also hardware limit switch configuration.

Motors

Step Width: - + μs

Enable Pin: Enable Invert On E-Stop Dynamic

Motor

Axis Output 1:	<input style="width: 100%;" type="text" value="X"/>	<input type="radio"/> Reverse	<input type="radio"/> Invert
Axis Output 2:	<input style="width: 100%;" type="text" value="Y"/>	<input type="radio"/> Reverse	<input type="radio"/> Invert
Axis Output 3:	<input style="width: 100%;" type="text" value="Z"/>	<input type="radio"/> Reverse	<input type="radio"/> Invert
Axis Output 4:	<input style="width: 100%;" type="text" value="---"/>	<input type="radio"/> Reverse	<input type="radio"/> Invert
Axis Output 5:	<input style="width: 100%;" type="text" value="---"/>	<input type="radio"/> Reverse	<input type="radio"/> Invert
Axis Output 6:	<input style="width: 100%;" type="text" value="---"/>	<input type="radio"/> Reverse	<input type="radio"/> Invert
Axis Output 7:	<input style="width: 100%;" type="text" value="---"/>	<input type="radio"/> Reverse	<input type="radio"/> Invert
Axis Output 8:	<input style="width: 100%;" type="text" value="---"/>	<input type="radio"/> Reverse	<input type="radio"/> Invert
Axis Output 9:	<input style="width: 100%;" type="text" value="---"/>	<input type="radio"/> Reverse	<input type="radio"/> Invert

2.9.14.1 *Step Width*

Width of STEP pulse. Units of parameter are micro seconds.

If step frequency is too high for inserted *Step Width* value, *Step Width* will be set to 50% of duty cycle.

2.9.14.2 *Enable Pin*

PlanetCNC controllers support *Enable* signal via enable pin located on controller axis output header.

Enable:

Enables use of Enable signal.

Invert:

Inverts enable signal(pulse) from 0V to 5V or from 5V to 0V to match your stepper driver requirements.

On E-Stop:

Enable signal is disabled when E-stop is active.

Dynamic:

Enable signal is enabled only when motion is applied to motors.

2.9.14.3 Motor

PlanetCNC controllers support up to 9* interpolated axis outputs, depending on controller used. Each axis output can generate steps for any of 9 linear or rotational axes.

Motors

Step Width: μs

Enable Pin: Enable Invert On E-Stop Dynamic

Motor

Axis Output 1:	<input type="text" value="X"/>	<input type="radio"/> Reverse	<input type="radio"/> Invert
Axis Output 2:	---	<input type="radio"/> Reverse	<input type="radio"/> Invert
Axis Output 3:	<input checked="" type="text" value="X"/>	<input type="radio"/> Reverse	<input type="radio"/> Invert
Axis Output 4:	Y	<input type="radio"/> Reverse	<input type="radio"/> Invert
Axis Output 5:	Z	<input type="radio"/> Reverse	<input type="radio"/> Invert
Axis Output 6:	A	<input type="radio"/> Reverse	<input type="radio"/> Invert
Axis Output 7:	B	<input type="radio"/> Reverse	<input type="radio"/> Invert
Axis Output 8:	C	<input type="radio"/> Reverse	<input type="radio"/> Invert
Axis Output 9:	U	<input type="radio"/> Reverse	<input type="radio"/> Invert
	V	<input type="radio"/> Reverse	<input type="radio"/> Invert
	W	<input type="radio"/> Reverse	<input type="radio"/> Invert

Axis Output 1-9*:

For each of 1-9* axis outputs you can select axis motor of your CNC.

If you need two axis outputs to generate synchronized steps (two axis outputs used for same machine axis -> slave axes) you just set same axis motor for both axis outputs:

Motor

Axis Output 1:	<input type="text" value="X"/>	<input type="radio"/> Reverse	<input type="radio"/> Invert
Axis Output 2:	<input type="text" value="Y"/>	<input type="radio"/> Reverse	<input type="radio"/> Invert
Axis Output 3:	<input type="text" value="Y"/>	<input type="radio"/> Reverse	<input type="radio"/> Invert
Axis Output 4:	<input type="text" value="Z"/>	<input type="radio"/> Reverse	<input type="radio"/> Invert

Reverse:

Reverses direction of motor rotation.

Invert:

Inverts step signal (pulse) from 0V to 5V or from 5V to 0V

**4 for Mk3/4 and Mk3ECO controllers*

2.9.14.4 Steps Per Unit

Steps per unit value (in further text SPU) defines how many step pulses controller needs to generate in order that machine axis moves for distance of one unit. Units can be in millimeters or in inches.

StepsPerUnit

StepsPerUnit

Motor X:	<input type="text" value="1600.00000"/>	- +	st/mm
Motor Y:	<input type="text" value="1600.00000"/>	- +	st/mm
Motor Z:	<input type="text" value="1600.00000"/>	- +	st/mm
Motor A:	<input type="text" value="100.00000"/>	- +	st/°
Motor B:	<input type="text" value="100.00000"/>	- +	st/°
Motor C:	<input type="text" value="100.00000"/>	- +	st/°
Motor U:	<input type="text" value="100.00000"/>	- +	st/mm
Motor V:	<input type="text" value="100.00000"/>	- +	st/mm
Motor W:	<input type="text" value="100.00000"/>	- +	st/mm

Motor settings for linear axes X,Y,Z, U ,V, W use steps per millimeter units (st/mm) or steps per inch (st/in), while motor settings for rotational axes A, B, C use steps per degree units (st/°).

2.9.14.5 Speed

You can set maximum speed of each axis motor. Motors will not exceed speed values set with these parameters.

Speed

Max Speed

Motor X:	<input type="text" value="2400.00"/>	<input type="button" value="-"/> <input type="button" value="+"/> mm/min
Motor Y:	<input type="text" value="2400.00"/>	<input type="button" value="-"/> <input type="button" value="+"/> mm/min
Motor Z:	<input type="text" value="2400.00"/>	<input type="button" value="-"/> <input type="button" value="+"/> mm/min
Motor A:	<input type="text" value="2400.00"/>	<input type="button" value="-"/> <input type="button" value="+"/> °/min
Motor B:	<input type="text" value="2400.00"/>	<input type="button" value="-"/> <input type="button" value="+"/> °/min
Motor C:	<input type="text" value="2400.00"/>	<input type="button" value="-"/> <input type="button" value="+"/> °/min
Motor U:	<input type="text" value="2400.00"/>	<input type="button" value="-"/> <input type="button" value="+"/> mm/min
Motor V:	<input type="text" value="2400.00"/>	<input type="button" value="-"/> <input type="button" value="+"/> mm/min
Motor W:	<input type="text" value="2400.00"/>	<input type="button" value="-"/> <input type="button" value="+"/> mm/min

2.9.14.6 Acceleration

You can set maximum acceleration and deceleration values of each axis motor.

Motors will not exceed acceleration and deceleration values set with these parameters.

Acceleration	
Max Acceleration	Max Deceleration
Motor X: <input type="text" value="250.00"/> <input type="button" value="-"/> <input type="button" value="+"/> mm/s ²	<input type="text" value="250.00"/> <input type="button" value="-"/> <input type="button" value="+"/> mm/s ²
Motor Y: <input type="text" value="250.00"/> <input type="button" value="-"/> <input type="button" value="+"/> mm/s ²	<input type="text" value="250.00"/> <input type="button" value="-"/> <input type="button" value="+"/> mm/s ²
Motor Z: <input type="text" value="250.00"/> <input type="button" value="-"/> <input type="button" value="+"/> mm/s ²	<input type="text" value="250.00"/> <input type="button" value="-"/> <input type="button" value="+"/> mm/s ²
Motor A: <input type="text" value="25.00"/> <input type="button" value="-"/> <input type="button" value="+"/> °/s ²	<input type="text" value="25.00"/> <input type="button" value="-"/> <input type="button" value="+"/> °/s ²
Motor B: <input type="text" value="25.00"/> <input type="button" value="-"/> <input type="button" value="+"/> °/s ²	<input type="text" value="25.00"/> <input type="button" value="-"/> <input type="button" value="+"/> °/s ²
Motor C: <input type="text" value="25.00"/> <input type="button" value="-"/> <input type="button" value="+"/> °/s ²	<input type="text" value="25.00"/> <input type="button" value="-"/> <input type="button" value="+"/> °/s ²
Motor U: <input type="text" value="25.00"/> <input type="button" value="-"/> <input type="button" value="+"/> mm/s ²	<input type="text" value="25.00"/> <input type="button" value="-"/> <input type="button" value="+"/> mm/s ²
Motor V: <input type="text" value="25.00"/> <input type="button" value="-"/> <input type="button" value="+"/> mm/s ²	<input type="text" value="25.00"/> <input type="button" value="-"/> <input type="button" value="+"/> mm/s ²
Motor W: <input type="text" value="25.00"/> <input type="button" value="-"/> <input type="button" value="+"/> mm/s ²	<input type="text" value="25.00"/> <input type="button" value="-"/> <input type="button" value="+"/> mm/s ²

2.9.14.7 Backlash

Set backlash compensation value if you machine has backlash.

Units of backlash compensation values for linear axes are in mm or inch, for rotational axes are in degrees.

Backlash

Backlash

Motor X:	<input type="text" value="0.00000"/>	<input type="button" value="-"/>	<input type="button" value="+"/>	mm
Motor Y:	<input type="text" value="0.00000"/>	<input type="button" value="-"/>	<input type="button" value="+"/>	mm
Motor Z:	<input type="text" value="0.00000"/>	<input type="button" value="-"/>	<input type="button" value="+"/>	mm
Motor A:	<input type="text" value="0.00000"/>	<input type="button" value="-"/>	<input type="button" value="+"/>	°
Motor B:	<input type="text" value="0.00000"/>	<input type="button" value="-"/>	<input type="button" value="+"/>	°
Motor C:	<input type="text" value="0.00000"/>	<input type="button" value="-"/>	<input type="button" value="+"/>	°
Motor U:	<input type="text" value="0.00000"/>	<input type="button" value="-"/>	<input type="button" value="+"/>	mm
Motor V:	<input type="text" value="0.00000"/>	<input type="button" value="-"/>	<input type="button" value="+"/>	mm
Motor W:	<input type="text" value="0.00000"/>	<input type="button" value="-"/>	<input type="button" value="+"/>	mm

Backlash

Backlash: Disable External Internal

Simulation: Disable Enable

2.9.14.7.1 Backlash

Disable: Disables backlash compensation.

External: Controller receives external command for backlash compensation. **Currently not supported.**

Internal: Enables backlash compensation. Software will generate additional steps necessary for backlash compensation.

2.9.14.7.2 Simulation

If *Simulation* is enabled in settings under chapter *Connection* (Chapter 2.7.2), you can enable or disable the backlash compensation in simulation mode.

Disable: Disables the backlash compensation in simulation mode.

Enable: Enable the backlash compensation in simulation mode.

2.9.14.8 Limits

You can set movement limitations for each axis motor.

Limits		
	Limit -	Limit +
Motor X:	<input type="text" value="-20.0000"/> <input type="button" value="-"/> <input type="button" value="+"/> mm <input checked="" type="checkbox"/>	<input type="text" value="200.0000"/> <input type="button" value="-"/> <input type="button" value="+"/> mm <input checked="" type="checkbox"/>
Motor Y:	<input type="text" value="-20.0000"/> <input type="button" value="-"/> <input type="button" value="+"/> mm <input checked="" type="checkbox"/>	<input type="text" value="350.0000"/> <input type="button" value="-"/> <input type="button" value="+"/> mm <input checked="" type="checkbox"/>
Motor Z:	<input type="text" value="-10.0000"/> <input type="button" value="-"/> <input type="button" value="+"/> mm <input checked="" type="checkbox"/>	<input type="text" value="40.0000"/> <input type="button" value="-"/> <input type="button" value="+"/> mm <input checked="" type="checkbox"/>
Motor A:	<input type="text" value="0.0000"/> <input type="button" value="-"/> <input type="button" value="+"/> ° <input type="radio"/>	<input type="text" value="0.0000"/> <input type="button" value="-"/> <input type="button" value="+"/> ° <input type="radio"/>
Motor B:	<input type="text" value="0.0000"/> <input type="button" value="-"/> <input type="button" value="+"/> ° <input type="radio"/>	<input type="text" value="0.0000"/> <input type="button" value="-"/> <input type="button" value="+"/> ° <input type="radio"/>
Motor C:	<input type="text" value="0.0000"/> <input type="button" value="-"/> <input type="button" value="+"/> ° <input type="radio"/>	<input type="text" value="0.0000"/> <input type="button" value="-"/> <input type="button" value="+"/> ° <input type="radio"/>
Motor U:	<input type="text" value="0.0000"/> <input type="button" value="-"/> <input type="button" value="+"/> mm <input type="radio"/>	<input type="text" value="0.0000"/> <input type="button" value="-"/> <input type="button" value="+"/> mm <input type="radio"/>
Motor V:	<input type="text" value="0.0000"/> <input type="button" value="-"/> <input type="button" value="+"/> mm <input type="radio"/>	<input type="text" value="0.0000"/> <input type="button" value="-"/> <input type="button" value="+"/> mm <input type="radio"/>
Motor W:	<input type="text" value="0.0000"/> <input type="button" value="-"/> <input type="button" value="+"/> mm <input type="radio"/>	<input type="text" value="0.0000"/> <input type="button" value="-"/> <input type="button" value="+"/> mm <input type="radio"/>

Limit- value sets limitation of motor movement in negative direction.

Limit+ value sets limitation of motor movement in positive direction.

If we want motors to stop when these limit values are reached, we must enable motor limitation.

To enable Motor limits for specified axis, enable the radio button.

2.9.14.9 Limit Switches

Using these parameters we can dedicate each axis motor its limit switch input.

We can assign limit switch input for each direction of motor movement.

Limit Switches		
	Limit -	Limit +
Motor X:	---	---
Motor Y:	---	---
Motor Z:	---	---
Motor A:	---	---
Motor B:	---	---
Motor C:	---	---
Motor U:	---	---
Motor V:	---	---
Motor W:	---	---
Limit Pin 1:	<input type="radio"/> Invert	<input type="radio"/> EStop
Limit Pin 2:	<input type="radio"/> Invert	<input type="radio"/> EStop
Limit Pin 3:	<input type="radio"/> Invert	<input type="radio"/> EStop
Limit Pin 4:	<input type="radio"/> Invert	<input type="radio"/> EStop
Limit Pin 5:	<input type="radio"/> Invert	<input type="radio"/> EStop
Limit Pin 6:	<input type="radio"/> Invert	<input type="radio"/> EStop
Limit Pin 7:	<input type="radio"/> Invert	<input type="radio"/> EStop
Limit Pin 8:	<input type="radio"/> Invert	<input type="radio"/> EStop
Limit Pin 9:	<input type="radio"/> Invert	<input type="radio"/> EStop

There are many methods of limit switch connection, and their corresponding limit setting configuration. Here are few examples.:

-One limit switch per axis motor, e.g. for axis X motor (positive direction), connected to controllers limit input 1:

	Limit -	Limit +
Motor X:	---	1
Motor Y:	---	---
Motor Z:	---	---
Motor A:	---	---
Motor B:	---	---
Motor C:	---	---
Motor U:	---	---
Motor V:	---	---
Motor W:	---	---

-Two limit switches for axis, e.g. for X motor (negative and positive direction), connected to same limit input of controller.

	Limit -	Limit +
Motor X:	1	1
Motor Y:	---	---
Motor Z:	---	---
Motor A:	---	---
Motor B:	---	---
Motor C:	---	---
Motor U:	---	---
Motor V:	---	---
Motor W:	---	---

-Two limit switches for axis, e.g. X motor (negative and positive direction), connected to separate limit inputs of controller, 1 and 2:

	Limit -	Limit +
Motor X:	1	2
Motor Y:	---	---
Motor Z:	---	---
Motor A:	---	---
Motor B:	---	---
Motor C:	---	---
Motor U:	---	---
Motor V:	---	---
Motor W:	---	---

Same principles that were shown above for X axis can be used for all other axes!

2.9.14.10 *Invert and Estop*

You can invert limit input located at *Limit* header and enable its Estop functionality.

Click the radio button to invert desired input.

In order that Estop is activated and machine stops during machine operation or jogging when limit switch is activated, you need to enable Estop radio button.

Limit Pin 1:	<input type="radio"/> Invert	<input type="radio"/> EStop
Limit Pin 2:	<input type="radio"/> Invert	<input type="radio"/> EStop
Limit Pin 3:	<input type="radio"/> Invert	<input type="radio"/> EStop
Limit Pin 4:	<input type="radio"/> Invert	<input type="radio"/> EStop
Limit Pin 5:	<input type="radio"/> Invert	<input type="radio"/> EStop
Limit Pin 6:	<input type="radio"/> Invert	<input type="radio"/> EStop
Limit Pin 7:	<input type="radio"/> Invert	<input type="radio"/> EStop
Limit Pin 8:	<input type="radio"/> Invert	<input type="radio"/> EStop
Limit Pin 9:	<input type="radio"/> Invert	<input type="radio"/> EStop

2.9.15 Motion

This settings tab deals with machine motion in 3D space (from effector (tool) point of view).

Short explanation:

With use of combined motors per axis and special mechanics you can achieve movement which doesn't follow the same kinematic rules as linear motion CNC's. At that moment we do not perceive each motor as independent axis but as a system, which movement is result of simultaneous motion of multiple motors. Examples of such machines are H-bot, Delta printer or multiple axis machines.

You can configure motion related parameters such as maximum machine/effector speeds, acceleration, deceleration. Machine motion range, blend and advanced settings.

Motion

Maximum Speed: - + mm/min

Max Acceleration: - + mm/s²

Max Deceleration: - + mm/s²

Motion XYZ: Enable

Motion ABC: Enable

Motion UVW: Enable

2.

9.15.1 Maximum Speed:

Sets maximum speed of tool/effector. Tool/effector will not exceed speed value set with this parameter.

2.9.15.2 Max Acceleration:

Sets maximum acceleration of tool/effector. Tool/effector will not exceed acceleration value set with this parameter.

2.9.15.3 Max Deceleration:

Sets maximum deceleration of your tool/effector. Tool/effector will not exceed deceleration value set with this parameter.

2.9.15.4 *Motion XYZ, ABC, UVW*

When coordinate system (XYZ...) is part of machine motion, it means that its speed and acceleration will cause forces acting on machine. When coordinate system is not part of machine motion, its speed and acceleration will not cause forces on machine. Typical example is tangential cutter or 3D printer extruder. This also affects G93 (inverse time mode) because non motion moves are not included in time calculation.

Note that motor accelerations and speeds are still considered.

2.9.15.5 Blend

This group of settings helps with tool-path optimization.

Blend

Blend Backlash: Disable Precise Loose

XYZ

Blend Tolerance: mm Enforce

Join Angle: Break Angle: °

ABC

Blend Tolerance: ° Enforce

Join Angle: Break Angle: °

UVW

Blend Tolerance: mm Enforce

Join Angle: Break Angle: °

2.9.15.5.1 Blend Backlash/Disable

When selected, blending of Backlash compensation moves is disabled.

2.9.15.5.2 Blend Backlash/Precise

When selected, blending of backlash moves is enabled, motion is well inside the CAM tolerance values.

2.9.15.5.3 Blend Backlash/Loose

When selected, blending of backlash moves is enabled, motion is not restricted by CAM tolerance values.

2.9.15.5.4 Enforce

If imported gcode program uses internal blend tolerance values, this option, when enabled, will enforce the use of blend tolerance value set here in settings.

2.9.15.5.5 XYZ/Blend Tolerance

XYZ axis tolerance(maximum distance) that blended toolpath can deviate from toolpath.

2.9.15.5.6 XYZ/Join Angle

Angle value of changed direction between machines current and next move. If angle is greater than this value, motion between these two moves will be blended.

Set at 0 by default.

2.9.15.5.7 XYZ/Break Angle

Angle value of changed direction between machines current and next move. If angle is greater than this value, motion between these two moves will not be blended.

Set at 135 by default.

2.9.15.5.8 ABC/Blend Tolerance

ABC axes tolerance (maximum distance) that blended toolpath can deviate from toolpath.

2.9.15.5.9 ABC/Join Angle

Angle value of changed direction between machines current and next move. If angle is greater than this value, motion between these two moves will be blended.

Set at 0 by default.

2.9.15.5.10 ABC/Break Angle

Angle value of changed direction between machines current and next move. If angle is greater than this value, motion between these two moves will not be blended.

Set at 135 by default.

2.9.15.5.11 UVW/Blend Tolerance

UVW axes tolerance (maximum distance) that blended toolpath can deviate from toolpath.

2.9.15.5.12 UVW/Join Angle

Angle value of changed direction between machines current and next move. If angle is greater than this value, motion between these two moves will be blended.

Set at 0 by default.

2.9.15.5.13 UVW/Break Angle

Angle value of changed direction between machines current and next move. If angle is greater than this value, motion between these two moves will not be blended.

Set at 135 by default.

More about path blending:

Blending is technique used to maximize cutting speed and minimizing machine stress. Machine stress that is discussed here is caused by forces that are result of accelerations.

Most are probably familiar with linear acceleration and deceleration limits that are set for each motor on machine. Settings "Motors/Acceleration". These settings prevent stress to machine motors. On machine with stepper motors this is known as "lost steps". But this is not only stress on machine.

When direction is changed, forces act on machine which cause stress and can ruin your workpiece. To prevent this it is possible to set maximum allowable acceleration that machine can handle.

Any sudden direction change at speed causes huge acceleration spike, therefore creating huge forces. That is why machine must slow down or even stop before such change. This causes longer machining time. Lower speed is also not good for tools which can overheat.

To deal with this issues we use path blending. Small arc is added to sharp corners and as a result, toolpath is much smoother and machine can run faster. We call this arcs "blends" because that is what they do. They blend toolpath segments to single smooth toolpath.

Here are 3 examples of direction change.

For first one, direction is changed for 5° , for second one for 45° and third one for 135° .

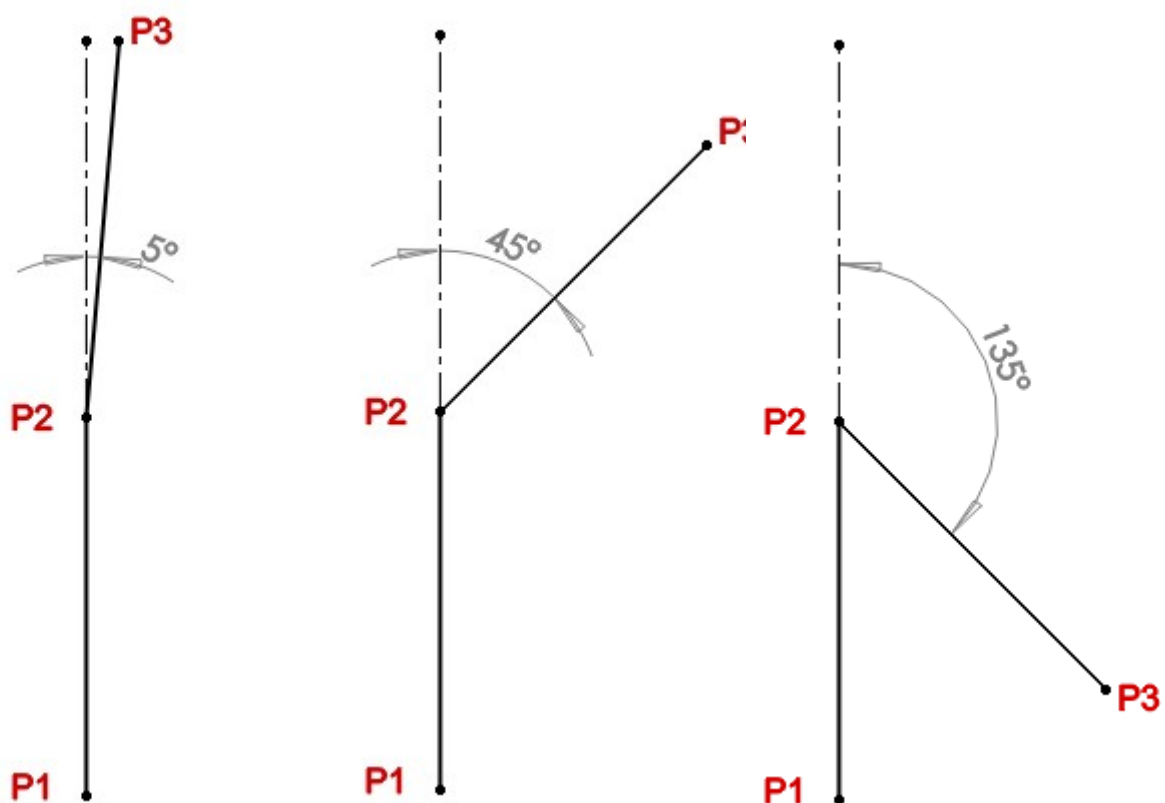

It is not beneficial to add blends to all direction changes. So it is possible to specify range of direction changes where blends are added by setting "Join angle" and "Break Angle". Only direction changes that are between these values are blended. By default "Join Angle" is 0 and "Break Angle" is 165.

Because blends alter toolpath, it is important to set allowable toolpath deviation from programmed toolpath. This is called "Blend Tolerance". Tolerance is maximal allowable deviation from programmed toolpath.

Here are three examples.

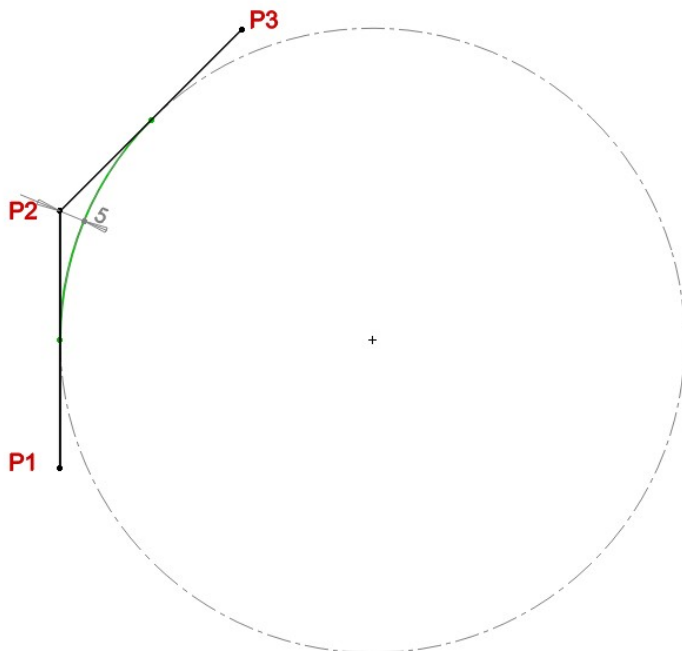
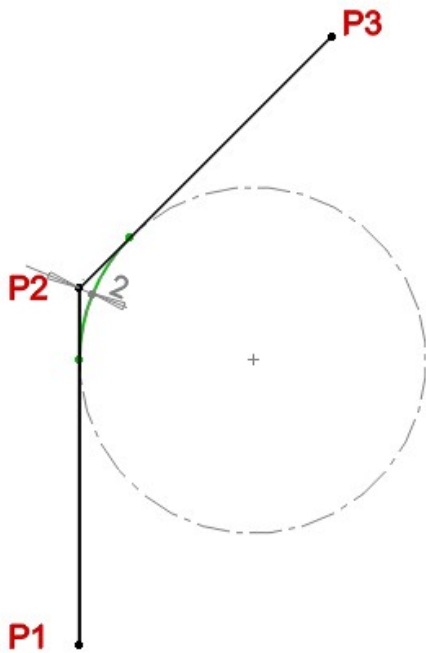

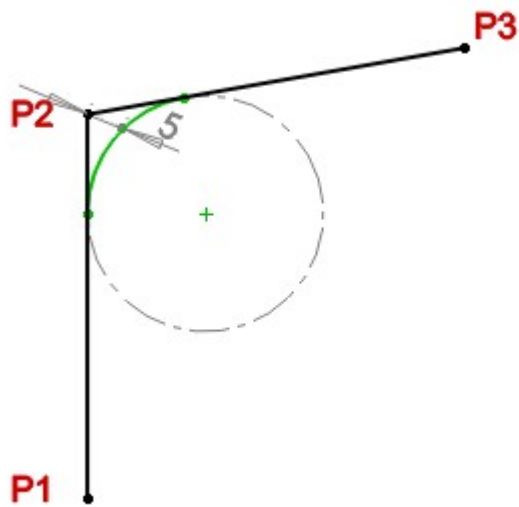

You can see that greater tolerance and/or smaller angle generates larger blend arcs. Moving on those arcs generates forces because of radial accelerations. Maximum radial acceleration is limited with settings “Motion/Max Acceleration” and “Motion/Max Deceleration”.

In most cases, specially with smaller angles, machine speed is not high enough that such big blends are needed. In these cases blends are smaller. Just big enough to allow maximum possible speed. This means that deviance from programmed toolpath is much smaller.

Blends are enabled by default and can be controlled with g-codes G61 and G64. For roughing operation blends are usually enabled with G64. For finishing operations blends can be disabled with G61 or tolerance can be set tighter with G64.

Here are two examples showing deviance with red color. Programmed toolpath is black, blend arc is green:

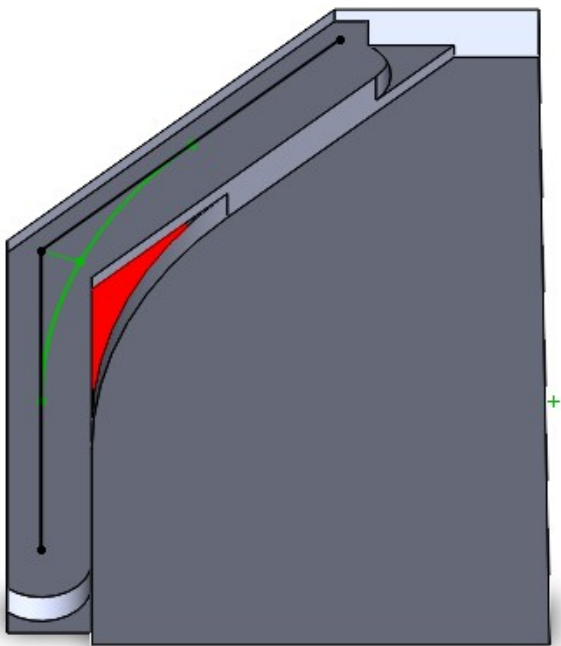
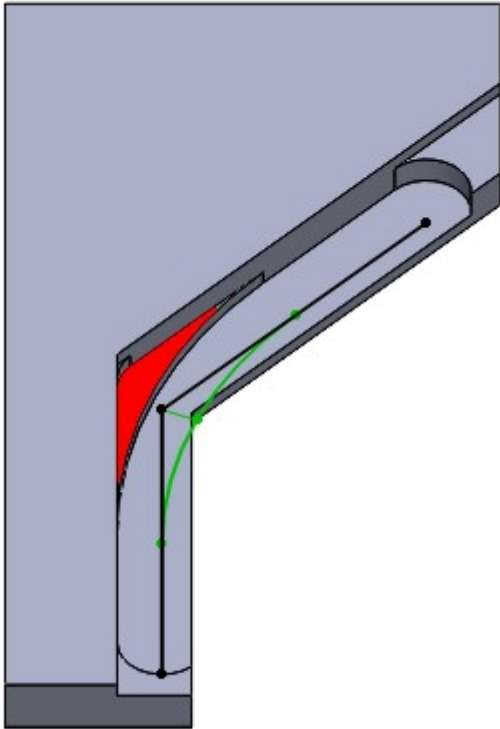

2.9.15.6 **Advanced**

Advanced

Cycle Time: - + sec

Motion Engine Buffer: - +

Device Buffer: - + - +

Device Max Packet: - +

Read Ahead: - +

Curve Tolerance: - + mm

2.9.15.6.1 **Cycle Time**

Motion interpolator cycle time.

Leave this at default value, otherwise controller will not function correctly.

2.9.15.6.2 **Motion Engine buffer**

Motion interpolator buffer size.

Leave this value at default value, otherwise controller will not work correctly.

2.9.15.6.3 **Device Buffer**

Controller buffer size. Lowering this value increases controller response time but also reduces fault tolerance. Using default value 128 is highly recommended.

Second field is used for Device Buffer value when software executes time critical tasks such as spindle synchronisation during thread cutting or rigid tapping. Value is lower for the sake of better response time.

2.9.15.6.4 **Device Max Packets**

Max size of data packets sent to controller.

Lowering this value reduces response time but also reduces fault tolerance.

Default value 5 is optimal balance between the response time and fault tolerance.

2.9.15.6.5 **Curve tolerance**

Motion interpolator curve interpolation parameter.

2.9.16 Jogging

With PlanetCNC TNG software you can use PC keyboard, jogging keyboard and MPG pendant to jog your machine. Under this group of settings you can configure jogging parameters.

Jogging

Default Speed: mm/min

Default Step: mm

Default Round: mm

Probe Lock: Enable

Jog Pin 1: Invert

Jog Pin 2: Invert

Jog Pin 3: Invert

Jog Pin 4: Invert

Jog Pin 5: Invert

Jog Pin 6: Invert

Jog Pin 7: Invert

Jog Pin 8: Invert

Jog Pin SHIFT: Invert

Jog Pin ALT1: Invert

Jog Pin ALT2: Invert

2.9.16.1 Default Speed

Default value of jogging speed. This speed value is used when jogging PC keyboard is used. The same value will be considered and displayed in jog segment. When PlanetCNC TNG is launched this value will be used.

Example:

Default speed set to 720 mm/min in settings.



2.9.16.2 Default Step

Distance of step when you jog your machine in “Step” mode. Units are millimeters/inch. When PlanetCNC TNG is launched this value will be used.

Example:

Step jogging comes very useful when you need short distance increments of motion. Usually when you need to move tool tip towards the material surface to set working position Z=0.

Jog inputs of controller are configured in Settings/User Interface/Shortcuts/Jogging -> Pin.

2.9.16.3 Default Round

Position rounding value. When jog motion stops, machine position value will be rounded value divisible with entered value.

Example:

Default round set to 0.5 mm. Bottom position values are final position values after jog motion. Position values are either rounded at 0.5 or 0.

Work	Machine	Motors	GCode
X	99.000		
Y	264.000		
Z	0.500		
A	0.000		

2.9.16.4 Probe Lock

When jogging, corresponding axis movement is locked if probe is activated. As soon as probe input is inactive, axis lock of dedicated axis is disabled.

When *Probe Lock* is enabled, in order to release the axis lock state, user needs to jog the axis in the opposite direction for short distance.

You can invert input pins of controllers *Jog* header.
Click the radio button to invert desired input.

Jog Pin 1:	<input type="radio"/> Invert
Jog Pin 2:	<input type="radio"/> Invert
Jog Pin 3:	<input type="radio"/> Invert
Jog Pin 4:	<input type="radio"/> Invert
Jog Pin 5:	<input type="radio"/> Invert
Jog Pin 6:	<input type="radio"/> Invert
Jog Pin 7:	<input type="radio"/> Invert
Jog Pin 8:	<input type="radio"/> Invert
Jog Pin SHIFT:	<input type="radio"/> Invert
Jog Pin ALT1:	<input type="radio"/> Invert
Jog Pin ALT2:	<input type="radio"/> Invert

2.9.16.5 Jogging Keyboard

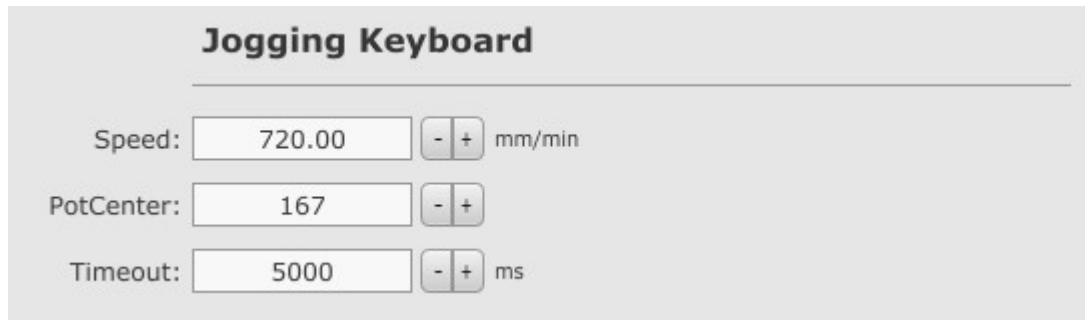

The screenshot shows a control panel titled "Jogging Keyboard". It contains three rows of controls:

- Speed:** A text input field containing "720.00", followed by a minus button, a plus button, and the unit "mm/min".
- PotCenter:** A text input field containing "167", followed by a minus button and a plus button.
- Timeout:** A text input field containing "5000", followed by a minus button, a plus button, and the unit "ms".

2.9.16.5.1 Speed

Default value of jogging speed when jogging keyboard is used. When PlanetCNC TNG is launched, this value will be used.

2.9.16.5.2 PotCenter

This parameter sets logarithmic/exponential behaviour of potentiometer response.

NOTE: To obtain this value, connect jogging keyboard to PlanetCNC controller and rotate jogging potentiometer. You can observe this value with *JogPot* parameter.

2.9.16.5.3 Timeout

Keyboard timeout if no keyboard change event is detected. After this time jogging stops.

2.9.16.6 Handwheel

PlanetCNC TNG software supports two types of Handwheel:

- PlanetCNC Handwheel, wireless
- PlanetCNC Handwheel, connected with PlanetCNC controller using CTRL header.

With this group of settings your configure jogging modes for both types of Handwheel.

Handwheel

Mode 1: Step <input type="radio"/>	Speed: <input style="width: 80px;" type="text" value="100.00"/>	- +	Round: <input style="width: 80px;" type="text" value="0.050"/>	- +
Mode 2: Step <input type="radio"/>	Speed: <input style="width: 80px;" type="text" value="800.00"/>	- +	Round: <input style="width: 80px;" type="text" value="0.100"/>	- +
Mode 3: Step <input type="radio"/>	Speed: <input style="width: 80px;" type="text" value="1500.00"/>	- +	Round: <input style="width: 80px;" type="text" value="1.000"/>	- +
Mode 4: Step <input type="radio"/>	Speed: <input style="width: 80px;" type="text" value="2400.00"/>	- +	Round: <input style="width: 80px;" type="text" value="1.000"/>	- +
Mode 5: Step <input checked="" type="radio"/>	Speed: <input style="width: 80px;" type="text" value="2400.00"/>	- +	Step: <input style="width: 80px;" type="text" value="1.000"/>	- +

Reverse:

Wireless Handwheel

Enable

Ctrl Handwheel

Enable

PPR: - + Reverse

2.9.16.6.1 Mode 1-5:

You can configure and use five jogging modes when using MPG pendant with PlanetCNC TNG. To select between modes you use Handwheel hardware switch (see handwheel user manual).

Each mode can be configured either as *Normal* or *Step*.

If radio button is left unchecked, Speed mode will be used, if you enable the radio button, Step mode will be used.

Handwheel

Mode 1: Step <input type="radio"/>	Speed: <input style="width: 80px;" type="text" value="100.00"/>	- +	Round: <input style="width: 80px;" type="text" value="0.050"/>	- +	
Mode 2: Step <input type="radio"/>	Speed: <input style="width: 80px;" type="text" value="800.00"/>	- +	Round: <input style="width: 80px;" type="text" value="0.100"/>	- +	
Mode 3: Step <input type="radio"/>	Speed: <input style="width: 80px;" type="text" value="1500.00"/>	- +	Round: <input style="width: 80px;" type="text" value="1.000"/>	- +	
Mode 4: Step <input type="radio"/>	Speed: <input style="width: 80px;" type="text" value="2400.00"/>	- +	Round: <input style="width: 80px;" type="text" value="1.000"/>	- +	
Mode 5: Step <input checked="" type="radio"/>	Speed: <input style="width: 80px;" type="text" value="2400.00"/>	- +	Step: <input style="width: 80px;" type="text" value="1.000"/>	- +	

Reverse:

Wireless Handwheel

Enable

Ctrl Handwheel

Enable

PPR: - + Reverse

Step Mode:

If you enable the *Step* radio button, corresponding jogging mode will be configured as Step mode. Rotation of encoder will jog machine in discrete short distance increments that are set with “Step” value.

Speed:

Speed of step jog moves.

Step:

In Step mode this value is interpreted as step distance increment.

Normal Mode:

If radio button is left unchecked, corresponding jogging mode will be configured as Normal mode. Rotation of encoder wheel will be translated into motion.

Speed:

Speed of jogging motion.

Round:

Position rounding value. When jog motion stops, machine position value will be rounded value divisible with entered value.

2.9.16.6.2 Reverse

Radio buttons represent reverse options for all 9 axes. From left to right: x,y,z,a....v,w.

When reverse option enabled, its corresponding axis will have reverse direction of jogging travel.

2.9.16.6.3 Wireless Handwheel

Enable:

Enables use of wireless Handwheel.

Radio button will be checked/unchecked automatically, depending if connection* between PlanetCNC TNG software and wireless MPG is established.

*USB driver needs to be installed, USB dongle transceiver must be connected with computer and Handwheel needs to be turned ON.

2.9.16.6.4 Ctrl Handwheel

Enable:

Enables use of Handwheel connected to controller CTRL header.

PPR:

Enter PPR value (parts per revolution) of Handwheel encoder. Usually around 100PPR.

Reverse:

Reverses direction of jogging when Handwheel is used for jogging.

Note: These settings apply to encoder connected to CTRL pins: EN1A and EN1B

2.9.17 Input/Output

Input/Output

E-Stop Pin: Enable Invert

Error Pin: Enable Invert

Input Pin 1: Invert

Input Pin 2: Invert

Input Pin 3: Invert

Input Pin 4: Invert

Input Pin 5: Invert

Input Pin 6: Invert

Input Pin 7: Invert

Input Pin 8: Invert

Output Pin 1: Invert

Output Pin 2: Invert

Output Pin 3: Invert

Output Pin 4: Invert

Output Pin 5: Invert

Output Pin 6: Invert

Output Pin 7: Invert

Output Pin 8: Invert

2.9.17.1 ***E-Stop Pin***

2.9.17.1.1 **Enable**

Enables E-stop input pin of controller.

2.9.17.1.2 **Invert**

Inverts E-stop input pin of controller.

2.9.17.2 ***Error Pin***

2.9.17.2.1 **Enable**

Enables Error input pin of controller(supported only with Mk3).

2.9.17.2.2 **Invert**

Inverts Error input pin of controller.

For more info on Error pin, please read Mk3 controller user manual.

2.9.17.3 ***Input Pin 1-8***

Click the radio button to invert desired input pin of controller.

2.9.17.4 ***Output Pin 1-8***

Click the radio button to invert desired output pin controller.

2.9.18 Spindle

This group of settings configures output pins for *Spindle* and *Coolant* control and input pins for encoder used for spindle synchronization.

NOTE: If you use Planet CNC Output board, you can follow this link to help you properly set output pins and connect output board to your controller.

Spindle

Output Pin - On/Off: CW/CCW

Output Pin - Direction:

Output Pin - Speed: Min: Max:

Start Delay: s Stop Delay: s

Frequency

Use Frequency:

Freq Min: Hz Freq Max: Hz

Step Width: μ s

PWM

Use PWM:

Frequency: Hz

RC

Use RC Servo:

RC Servo Lo: ms RC Servo Hi: ms

Encoder

PPR: Reverse

Index PPR: / Invert

Debounce: ms

Synchronization

Spindle RPM: As Set From Index From Encoder

Sync Signal: None From Index From Encoder

2.9.18.1 *Output Pin – CW*

Assigns output pin for spindle ON/OFF clockwise control (g-code commands M3/M5) .
Digital output pin is selected trough drop down menu.

2.9.18.2 *Output Pin – CCW*

Assigns output pin for spindle ON/OFF counter clockwise control (g-code commands M4/M5).
Digital output pin is selected trough drop down menu.

2.9.18.3 *Output Pin – Speed*

Some controller output pins can generate Frequency, PWM and RC servo signal.
If neither of the latter two is selected, spindle speed pin will generate frequency modulated signal.

2.9.18.3.1 *Min*

Inserted value is min value of spindle RPM. Meaning, when g-code e.g. S1200 will be executed in program, controller speed pin will be generating min value of either output frequency, PWM modulated signal or RC Servo signal.

2.9.18.3.2 *Max*

Inserted value is max value of spindle RPM. Meaning, when g-code e.g. S24000 will be executed in program, controller speed pin will be generating max value of either output frequency, PWM modulated signal or RC Servo signal.

2.9.18.4 *Start Delay*

Delay period allowing the spindle to ramp up to its RPM value. This value is in seconds.

2.9.18.5 *Stop Delay*

Delay period allowing the spindle to stop rotating. This value is in seconds.

2.9.18.6 *Frequency*

2.9.18.6.1 **Use Frequency**

When enabled, *Speed Pin* will generate frequency signal.

Freq. Min, Freq. Max and Step Width parameters will be considered.

2.9.18.6.2 **Freq Min**

Frequency value of generated speed signal when S gcode *Min. value* of Speed signal is used in program.

2.9.18.6.3 **Freq Max**

Frequency value of generated speed signal when S gcode *Max. value* of Speed signal is used in program.

2.9.18.6.4 **Step Width**

Entered value is pulse width of generated speed signal.

When set at 0, duty cycle of generated speed signal is at 50%.

2.9.18.7 *PWM*

When enabled, *Speed Pin* will generate PWM signal.
PWM frequency will be considered.

2.9.18.7.1 **Frequency**

Value of PWM base frequency.

2.9.18.8 *RC*

2.9.18.8.1 **Use RC Servo**

When enabled, *Speed Pin* will generate RC Servo signal.
RC Servo Lo-HI parameters will be considered.

2.9.18.8.2 **RC Servo Lo**

Minimum value of RC servo speed range.

2.9.18.8.3 **RC Servo Hi**

Maximum value of RC servo speed range

2.9.18.9 Encoder

These settings apply to encoder connected to CTRL pins: EN4A and EN4B for Mk3 controller and ENC A and ENC B for Mk3/4 controller.

2.9.18.9.1 PPR

PPR value of your encoder. We recommend 100 PPR encoder for best results.

Reverse: Enables reverse direction of encoder.

2.9.18.9.2 Index PPR

First / Second input window define ratio between index signal and spindle revolution.

Example without reduction:

Most commonly we have one index signal per one revolution: **1/1**

The screenshot shows the 'Encoder' settings panel. It includes three rows of controls: 'PPR' with a text input field containing '100' and a numeric spinner; 'Index PPR' with two text input fields containing '1' and '1' separated by a slash, each with a numeric spinner; and 'Debounce' with a text input field containing '1000' and a numeric spinner followed by 'ms'. On the right side, there are two radio buttons: 'Reverse' (which is selected) and 'Invert'.

Sometimes we have multiple index sensors, typically on lathes, for example three index sensors will give you signal every 120deg of revolution. So the ratio in such case would be: **3/1**

This screenshot is similar to the previous one but shows a different Index PPR ratio. The 'Index PPR' section now has two text input fields containing '3' and '1' separated by a slash, each with a numeric spinner. The 'PPR' field remains '100' and 'Debounce' remains '1000 ms'. The 'Reverse' radio button is still selected.

Example with reduction:

If we use *reductor* i.e. gears between spindle motor and spindle.

a) Spindle motor and spindle **ratio: 1 : 2.5** (400RPM on motor = 1000 RPM on spindle):

Because it is not possible to know the position of 2.5 revolution, we need to round our ratio to nearest integer. In this case this is 2 index signals per 5 revolutions.

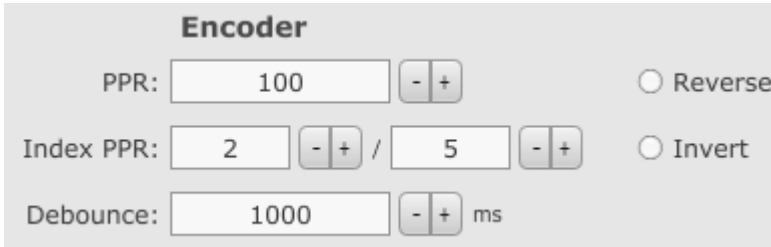

The image shows a software interface for configuring an encoder. It is titled "Encoder" and contains three rows of controls. The first row is labeled "PPR:" and has a text input field containing "100", followed by a pair of minus and plus buttons, and a radio button labeled "Reverse". The second row is labeled "Index PPR:" and has two text input fields: the first contains "2" and the second contains "5", separated by a slash. Each of these fields has a pair of minus and plus buttons. To the right of these fields is a radio button labeled "Invert". The third row is labeled "Debounce:" and has a text input field containing "1000", followed by a pair of minus and plus buttons, and the text "ms".

b) Spindle motor and spindle **ratio: 2.5 : 1** (1000RPM on motor = 400 RPM on spindle):

Similarly, counting two and a half index pulses, rounding is also required. This gives us 5 index signals per 2 revolutions:

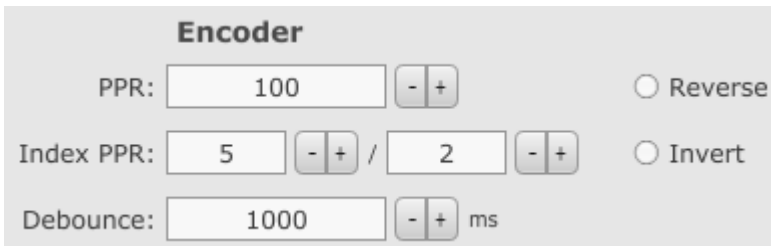

The image shows a software interface for configuring an encoder, similar to the one above. It is titled "Encoder" and contains three rows of controls. The first row is labeled "PPR:" and has a text input field containing "100", followed by a pair of minus and plus buttons, and a radio button labeled "Reverse". The second row is labeled "Index PPR:" and has two text input fields: the first contains "5" and the second contains "2", separated by a slash. Each of these fields has a pair of minus and plus buttons. To the right of these fields is a radio button labeled "Invert". The third row is labeled "Debounce:" and has a text input field containing "1000", followed by a pair of minus and plus buttons, and the text "ms".

Invert: Inverts Index signal.

2.9.18.9.3 Debounce

Debounce time value for encoder signals.

2.9.18.10 Synchronisation

2.9.18.10.1 Spindle RPM

As Set:

Value of spindle speed (RPM) used for synchronisation move speed will be the one using current spindle speed value.

From Index:

Value of spindle speed (RPM) used for synchronisation move speed will be calculated using Index signal.

From Encoder:

Value of spindle speed (RPM) used for synchronisation move speed will be calculated using Encoder signals.

2.9.18.10.2 Sync Signal

Sync Signal:

If *None* is enabled, then machine does not use neither, index signal or encoder signals for spindle synchronisation. Sync signal is not used.

From Index:

Index signal will be used for determining starting point of first synchronisation move, e.g. threading cycle.

From encoder:

Encoder signals will be used for determining starting point of first synchronisation move, e.g. threading cycle.

2.9.19 Coolant

Here you can set digital output pins of controller for coolant control such as Mist and Flood.



The screenshot shows a configuration window titled "Coolant". It is divided into two sections: "Mist" and "Flood". Under the "Mist" section, there is a label "Output Pin - Mist:" followed by a dropdown menu with the number "7" selected. Under the "Flood" section, there is a label "Output Pin - Flood:" followed by a dropdown menu with the number "8" selected.

2.9.19.1 Mist

Assigns output pin for coolant 'Mist' ON/OFF control. (g-code commands M7/M9).

Digital output pin is selected through drop down menu.

2.9.19.2 Flood

Assigns output pin for coolant 'Flood' ON/OFF control. (g-code commands M8/M9).

Digital output pin is selected through drop down menu.

2.9.20 I2C, TX, Ext

You can connect and control external devices with PlanetCNC TNG software and hardware. I2C, serial or SPI communication protocols are supported.

I2C, TX, Ext

I2C

Frequency:

TX

Baudrate:

Encoder

PPR: Reverse

Ext

Frequency:

SEL1

SEL1 Pin: Invert

In Size Out Size Timer

SEL2

SEL2 Pin: Invert

In Size Out Size Timer

2.9.20.1 I2C

2.9.20.1.1 Frequency

Base frequency value of I2C communication protocol.

2.9.20.2 TX

2.9.20.2.1 Baudrate

Baudrate value of serial communication.

2.9.20.3 Encoder

2.9.20.3.1 PPR

PPR value of encoder.

Note: These settings apply to encoder connected to Mk3 controller CTRL pins: EN2A and EN2B

2.9.20.3.2 Reverse

Enables reverse direction of encoder.

2.9.20.4 Ext

2.9.20.4.1 Frequency

Frequency value of SPI communication protocol.

2.9.20.4.2 SEL1 Pin

Invert: Polarity of SSEL pin. Unchecked = active high, checked = active low

In Size:

Size of received data (number of bytes) from external SPI device that uses SEL1 pin.

Out size:

Size of sent data (number of bytes) to external SPI device that uses SEL1 pin.

Timer:

Time period of data re-sending and/or re-reading.

2.9.20.4.3 SEL2 Pin

Invert: Polarity of SSEL pin. Unchecked = active high, checked = active low

In Size:

Size of received data (number of bytes) from external SPI device that uses SEL2 pin.

Out size:

Size of sent data (number of bytes) to external SPI device that uses SEL2 pin.

Timer:

Time period of data re-sending and/or re-reading.

2.9.21 THC

Options available for THC device control.

The screenshot shows the 'THC' control panel with the following settings:

- Axis: ---
- Dec Pin: ---
- Inc Pin: ---
- OK Pin: ---
- Range Min: 0.0 mm
- Max: 0.0 mm
- Speed: 10.0 mm/s

2.9.21.1 Axis

User selects machine axis from drop down menu. Selected axis will be height compensated.

The screenshot shows the 'THC' control panel with the 'Axis' dropdown menu open. The selected axis is 'Z'. The menu options are: ---, X, Y, Z (checked), A, B, C, U, V, W. Other settings visible include:

- Dec Pin: ---
- Inc Pin: ---
- Max: 0.0 mm

2.9.21.2 *Dec Pin*

Dec input pin number, located at INPUT header of controller.

When this input pin is active, machine move/compensate in negative direction.

2.9.21.3 *Inc Pin*

Inc input pin number, located at INPUT header of controller.

When this input pin is active, machine move/compensate in positive direction.

2.9.21.4 *OK Pin*

OK input pin number, located at INPUT header of controller.

If set, machine waits until this input is active.

2.9.21.5 *Range Min*

Low limit compensation travel.

2.9.21.6 *Range Max*

High limit compensation travel.

2.9.21.7 *Speed*

Speed of compensation moves. Units are mm/s or inch/s.

2.9.22 Program Options

Program options values are meant for initialization of main interpreter states/values in order to prevent any unpredicted machine behaviour on software start.

Program Options

Mode

Units:

Plane:

Distance Mode:

Distance Mode IJK:

Distance Mode ABC:

Cycle Return Mode:

Lathe Mode:

Speed

Traverse Speed: mm/min

Traverse Speed ABC: °/min

Feed Speed: mm/min

Spindle Speed: RPM

Transformation

A0: <input type="text" value="1.0000"/> <input type="button" value="-"/> <input type="button" value="+"/>	B0: <input type="text" value="0.0000"/> <input type="button" value="-"/> <input type="button" value="+"/>	C0: <input type="text" value="0.0000"/> <input type="button" value="-"/> <input type="button" value="+"/>
A1: <input type="text" value="0.0000"/> <input type="button" value="-"/> <input type="button" value="+"/>	B1: <input type="text" value="1.0000"/> <input type="button" value="-"/> <input type="button" value="+"/>	C1: <input type="text" value="0.0000"/> <input type="button" value="-"/> <input type="button" value="+"/>
A2: <input type="text" value="0.0000"/> <input type="button" value="-"/> <input type="button" value="+"/>	B2: <input type="text" value="0.0000"/> <input type="button" value="-"/> <input type="button" value="+"/>	C2: <input type="text" value="1.0000"/> <input type="button" value="-"/> <input type="button" value="+"/>
A3: <input type="text" value="0.0000"/> <input type="button" value="-"/> <input type="button" value="+"/>	B3: <input type="text" value="0.0000"/> <input type="button" value="-"/> <input type="button" value="+"/>	C3: <input type="text" value="0.0000"/> <input type="button" value="-"/> <input type="button" value="+"/>

2.9.22.1 Mode

2.9.22.1.1 Units

Measurement unit mode.

User can choose between G20 or G21.

2.9.22.1.2 Plane

Plane mode.

User can choose between G17,G18 or G19.

2.9.22.1.3 Distance Mode

Distance mode.

User can choose between G90 or G91

2.9.22.1.4 Distance Mode IJK

Distance mode IJK.

User can choose between G90.1 or G91.1.

2.9.22.1.5 Distance Mode ABC

Distance mode ABC.

User can choose between G90.2 or G91.2.

2.9.22.1.6 Cycle Return Mode

Cycle Return Mode.

User can choose between G98 or G99.

2.9.22.1.7 Lathe Mode

Lathe mode.

User can choose between G07 or G08.

2.9.22.2 *Speed*

2.9.22.2.1 *Traverse Speed*

G-code programs include traverse(aka rapid) machine moves. During these moves, machine is not cutting the material, instead it is moving above the material usually moving to next cutting position.

These moves are executed with G00 g-code command.

You cannot set speed value of traverse moves with corresponding g-code command (unlike feed speed with F-word).

With this parameter you can set default speed value of traverse machine moves when G00 command is executed in program.

2.9.22.2.2 *Traverse Speed ABC*

G-code programs include traverse(aka rapid) machine moves. During these moves, machine is not cutting the material, instead it is moving above the material usually moving to next cutting position.

These moves are executed with G00 g-code command.

You cannot set speed value of traverse moves with corresponding g-code command (unlike feed speed with F-word).

With this parameter you can set default speed value of traverse machine moves when G00 command is executed in program.

2.9.22.2.3 *Feed Speed*

G-code programs include feed machine moves. These moves are executed with G01 g-code command. During these moves machine is cutting the material.

Speed of feed moves is set with F-word g-code command. If g-code program does not include F-word g-code, then value of this parameter will be used in program.

2.9.22.2.4 *Spindle Speed*

Spindle speed is value of RPM(Rotations Per Minute) of Spindle. In g-code program, this is set by S-word g-code command. If your g-code program does not include S-word command, then value of this parameter will be taken into the account.

2.9.22.3 *Transformation*

Default transformation coefficient values. If you manually change these values or set them via Program/Transformation/Set As Default, this transformation configuration will be used each time you start PlanetCNC TNG sw.

2.9.23 Paths

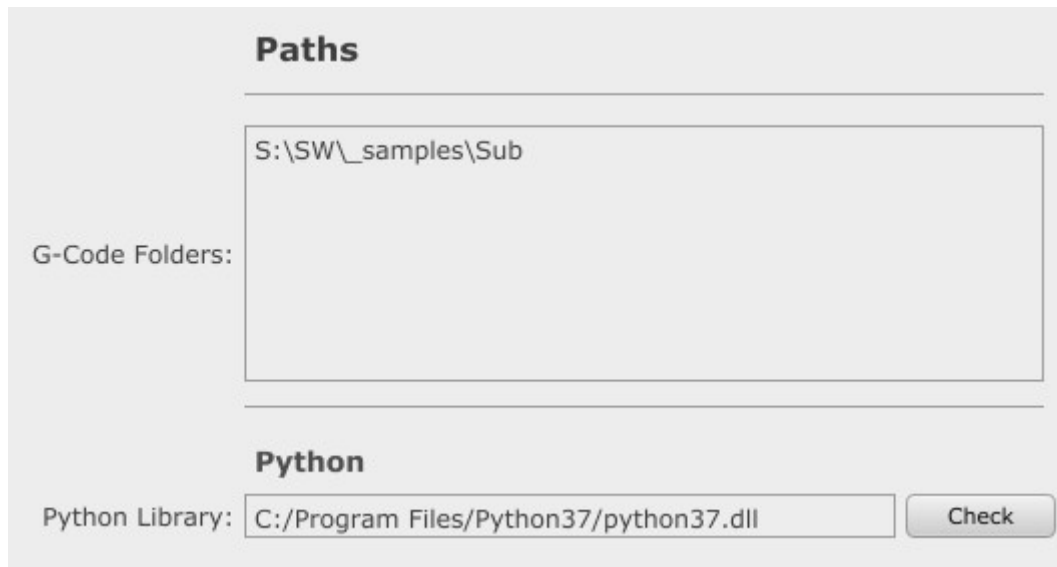

The screenshot shows a configuration window titled "Paths". It is divided into two sections. The top section, "G-Code Folders:", contains a text input field with the path "S:\SW_samples\Sub". The bottom section, "Python", contains a text input field for the "Python Library:" with the path "C:/Program Files/Python37/python37.dll" and a "Check" button to its right.

2.9.23.1 G-Code folders

Path to folders that contain sub procedure files.

2.9.23.2 Python

2.9.23.2.1 Python Library

Path to Python library.

2.9.24 Scripts

PlanetCNC TNG software supports use of scripts. Scripts are essentially g-code programs that run in the background of PlanetCNC TNG procedures(such as homing, tool change etc...).

You select procedure script file from drop down menu. To open script file in text editor click button Edit Script.

Scripts

Tools
Command: ---

Move
Command: ---

Machine Position
Command: ---

Work Position
Command: ---

Work Position - Offset
Command: ---

Coordinate System
Command: ---

Coordinate System - Offset
Command: ---

Tool Offset
Command: ---

Home & Measure
Command: ---

M-Code
Command: ---

You can edit scripts for:

2.9.24.1.1 Tools:

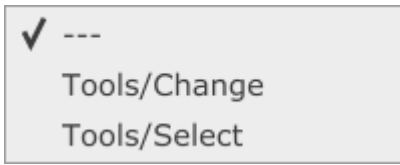

Tools/Change

Tools/Select

2.9.24.1.2 Move:

✓ ---
Move/To Zero
Move/To ...
Move/Axis To Zero/X
Move/Axis To Zero/Y
Move/Axis To Zero/Z
Move/Axis To Zero/A
Move/Axis To Zero/B
Move/Axis To Zero/C
Move/Axis To Zero/U
Move/Axis To Zero/V
Move/Axis To Zero/W
Move/Axis To Zero/XY
Move/Axis To Zero/UV
Move/To G28
Move/To G30
Move/To Selected Line
Move/To Selected Line XY
Move/Position To Camera
Move/Camera To Position
Move/Camera To Selected Line XY

Move/To Zero

Move/To...

Move/Axis to Zero/X

Move/Axis to Zero/Y

Move/Axis to Zero/Z

Move/Axis to Zero/A

Move/Axis to Zero/B

Move/Axis to Zero/C

Move/Axis to Zero/U

Move/Axis to Zero/V

Move/Axis to Zero/W

Move/Axis to Zero/XY

Move/Axis to Zero/UV
 Move/To G28
 Move/To G30
 Move/To Selected Line
 Move/To Selected Line XY
 Move/Position to Camera
 Move/Camera To Position

2.9.24.1.3 Machine Position

- ✓ ---
- Machine Position/To Zero
- Machine Position/To ...
- Machine Position/Axis To Zero/X
- Machine Position/Axis To Zero/Y
- Machine Position/Axis To Zero/Z
- Machine Position/Axis To Zero/A
- Machine Position/Axis To Zero/B
- Machine Position/Axis To Zero/C
- Machine Position/Axis To Zero/U
- Machine Position/Axis To Zero/V
- Machine Position/Axis To Zero/W
- Machine Position/Axis To Zero/XY
- Machine Position/Axis To Zero/UV
- Machine Position/As G28
- Machine Position/As G30

Machine Position/To Zero
 Machine Position/To...
 Machine Position/Axis To Zero/X
 Machine Position/Axis To Zero/Y
 Machine Position/Axis To Zero/Z
 Machine Position/Axis To Zero/A
 Machine Position/Axis To Zero/B
 Machine Position/Axis To Zero/C
 Machine Position/Axis To Zero/U

Machine Position/Axis To Zero/V
Machine Position/Axis To Zero/W
Machine Position/Axis To Zero/W
Machine Position/Axis To Zero/XY
Machine Position/Axis To Zero/UV
Machine Position/To G28
Machine Position/To G30
Machine Position/As G28
Machine Position/As G30

2.9.24.1.4 Work Position

✓ ---
Work Position/To Zero
Work Position/To ...
Work Position/Axis To Zero/X
Work Position/Axis To Zero/Y
Work Position/Axis To Zero/Z
Work Position/Axis To Zero/A
Work Position/Axis To Zero/B
Work Position/Axis To Zero/C
Work Position/Axis To Zero/U
Work Position/Axis To Zero/V
Work Position/Axis To Zero/W
Work Position/Axis To Zero/XY
Work Position/Axis To Zero/UV
Work Position/Measure Height
Work Position/Selected Line
Work Position/Selected Line XY
Work Position/Camera XY

Work Position/To Zero
Work Position/To...
Work Position/Axis to Zero/X
Work Position/Axis to Zero/Y

Work Position/Axis to Zero/Z
 Work Position/Axis to Zero/A
 Work Position/Axis to Zero/B
 Work Position/Axis to Zero/C
 Work Position/Axis to Zero/U
 Work Position/Axis to Zero/V
 Work Position/Axis to Zero/W
 Work Position/Axis to Zero/XY
 Work Position/Axis to Zero/UV
 Work Position/Measure
 Work Position/Selected Line
 Work Position/Selected Line XY
 Work Position/Camera XY

2.9.24.1.5 Work Position - Offset

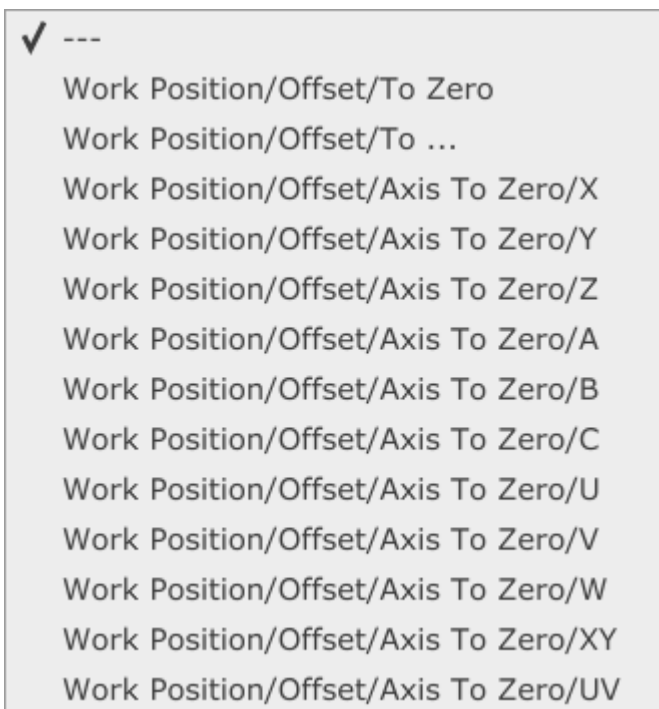

Work Position/Offset/To Zero
 Work Position/Offset/To
 Work Position/Offset/Axis To Zero/X
 Work Position/Offset/Axis To Zero/Y

Work Position/Offset/Axis To Zero/Z
 Work Position/Offset/Axis To Zero/A
 Work Position/Offset/Axis To Zero/B
 Work Position/Offset/Axis To Zero/C
 Work Position/Offset/Axis To Zero/U
 Work Position/Offset/Axis To Zero/V
 Work Position/Offset/Axis To Zero/W
 Work Position/Offset/Axis To Zero/XY
 Work Position/Offset/Axis To Zero/UW

2.9.24.1.6 Tool Offset



Tool Offset/To Zero
 Tool Offset/To...
 Tool Offset/Axis To Zero/X
 Tool Offset/Axis To Zero/Y
 Tool Offset/Axis To Zero/Z
 Tool Offset/Axis To Zero/A
 Tool Offset/Axis To Zero/B
 Tool Offset/Axis To Zero/C

Tool Offset/Axis To Zero/U
Tool Offset/Axis To Zero/V
Tool Offset/Axis To Zero/W
Tool Offset/Axis To Zero/XY
Tool Offset/Axis To Zero/UV
Tool Offset/Measure Tool Length
Tool Offset/From Tool Table

2.9.24.1.7 Coordinate System

✓ ---
Coordinate System/Select/1
Coordinate System/Select/2
Coordinate System/Select/3
Coordinate System/Select/4
Coordinate System/Select/5
Coordinate System/Select/6
Coordinate System/Select/7
Coordinate System/Select/8
Coordinate System/Select/9
Coordinate System/To Zero
Coordinate System/To ...
Coordinate System/Axis To Zero/X
Coordinate System/Axis To Zero/Y
Coordinate System/Axis To Zero/Z
Coordinate System/Axis To Zero/A
Coordinate System/Axis To Zero/B
Coordinate System/Axis To Zero/C
Coordinate System/Axis To Zero/U
Coordinate System/Axis To Zero/V
Coordinate System/Axis To Zero/W
Coordinate System/Axis To Zero/XY
Coordinate System/Axis To Zero/UV
Coordinate System/Measure Height

Coordinate System/Select/1

Coordinate System/Select/2
Coordinate System/Select/3
Coordinate System/Select/4
Coordinate System/Select/5
Coordinate System/Select/6
Coordinate System/Select/7
Coordinate System/Select/8
Coordinate System/Select/9
Coordinate System/To Zero
Coordinate System/To...
Coordinate System/Axis To Zero/X
Coordinate System/Axis To Zero/Y
Coordinate System/Axis To Zero/Z
Coordinate System/Axis To Zero/A
Coordinate System/Axis To Zero/B
Coordinate System/Axis To Zero/C
Coordinate System/Axis To Zero/U
Coordinate System/Axis To Zero/V
Coordinate System/Axis To Zero/W
Coordinate System/Axis To Zero/W
Coordinate System/Axis To Zero/XY
Coordinate System/Axis To Zero/UV

2.9.24.1.8 Home & Measure

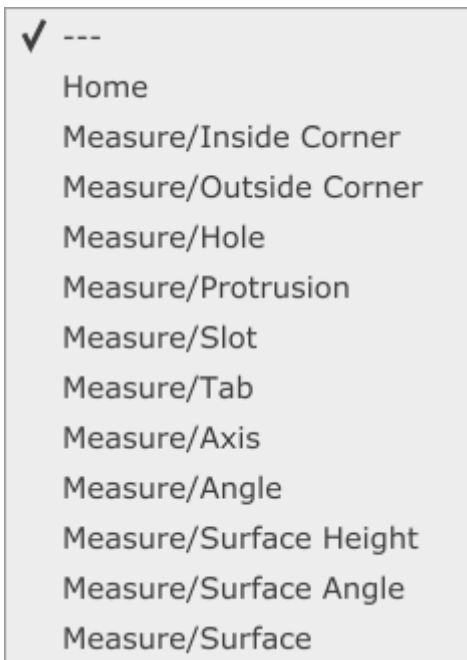

Home

Measure/Inside Corner

Measure/Outside Corner

Measure/Hole

Measure/Protrusion

Measure/Slot

Measure/Tab

Measure/Axis

Measure/Angle

Measure/Surface Height

Measure/Surface Angle

Measure/Surface

2.9.24.1.9 M-Code

<input checked="" type="checkbox"/>	---
<input type="checkbox"/>	M2
<input type="checkbox"/>	M3
<input type="checkbox"/>	M4
<input type="checkbox"/>	M5
<input type="checkbox"/>	M6
<input type="checkbox"/>	M7
<input type="checkbox"/>	M8
<input type="checkbox"/>	M9

- M3
- M4
- M5
- M6
- M7
- M8
- M9

2.9.25 Events

Events

Start From Line

Restore State: Enable

Restore Mist: Enable

Restore Flood: Enable

Restore Spindle: Enable

Restore Position: Enable

EStop

Outputs Off: Enable

Stop Mist: Enable

Stop Flood: Enable

Stop Spindle: Enable

OnStart

Script: [Edit Script](#)

OnEnd

Script: [Edit Script](#)

OnStop

Script: [Edit Script](#)

2.9.25.1 Start From Line

User can define if Spindle, Flood and Mist outputs are restored when using program feature Start From Selected Line.

2.9.25.1.1 Restore State

When enabled, complete state will be restored. Software will consider last state to the point of selected program line.

2.9.25.1.2 Restore Mist

When enabled, Mist output will be restored. Software will consider last Mist output state (M7/M9) to the point of selected program line.

2.9.25.1.3 Restore Flood

When enabled, Flood output will be restored. Software will consider last Flood output state (M8/M9) to the point of selected program line.

2.9.25.1.4 Restore Spindle

When enabled, Spindle output will be restored. Software will consider last Spindle output state (M3/M5) to the point of selected program line.

2.9.25.2 Estop

User can define if controller outputs and Spindle, Flood and Mist outputs are turned off when using Estop is activated.

2.9.25.2.1 Outputs Off

When enabled, all controller outputs will be turned off.

2.9.25.2.2 Stop Mist

When enabled, Mist output will be turned off when Estop is activated.

2.9.25.2.3 Stop Flood

When enabled, Flood output will be turned off when Estop is activated.

2.9.25.2.4 Stop Spindle

When enabled, Spindle output will be turned off when Estop is activated.

2.9.25.3 *On Start*

User can edit script code which will execute on Start event.

2.9.25.4 *On End*

User can edit script code which will execute on program end event.

2.9.25.5 *On Stop*

User can edit script code which will execute on Stop event.

2.9.26 Probe & Measure

Here you can set probe parameters regarding Measure procedures under Machine/Measure.

Probe & Measure

Probe 1 Pin:

Probe 2 Pin:

Probe Speed: mm/min Low: mm/min

Probe Size Z: mm

Probe Size XY: mm

Safe Height: mm

Probe EStop: Enable

2.9.26.1 Probe 1 Pin

Assigns digital input pin as Probe 1. Input pin is selected from drop down menu.

2.9.26.2 Probe 2 Pin

Assigns digital input pin as Probe 2. Input pin is selected from drop down menu.

2.9.26.3 Probe speed

Probe speed is speed at which machine measures different geometries under Machine/Measure menu.

2.9.26.4 Low

After initial first probe activation, machine will repeat measurement again, but this time at *Low* speed.

2.9.26.5 *Probe Size Z*

Length of probe.

2.9.26.6 *Probe Size XY*

Radius of the stylus ball of touching probe.

2.9.26.7 *Safe Height*

Height value to which machine ascends in-between measurement procedure.

With *Copy Motor Limits* button user can insert the field with value of Z axis motor limit value.

2.9.26.8 *Probe Estop*

With this option enabled, during program run(gcode, MDI command...), if probe will be tripped, Estop will be activated.

2.9.27 Home

Under this tab user can configure parameters for Homing procedure.

Home

Speed: mm/min Low: mm/min

Order: X: Y: Z:

A: B: C:

U: V: W:

Direction: X: - + Y: - + Z: - +

A: - + B: - + C: - +

U: - + V: - + W: - +

Switch Position: X: Y: Z: mm

A: B: C: °

U: V: W: mm

Move To: X: Y: Z: mm

A: B: C: °

U: V: W: mm

Switch Click Distance: mm

2.9.27.1 Speed

With this parameter you can set at which speed machine will reference its axes when homing procedure will be executed.

E.g.: We set Speed at 1000mm/min

Homing of each axis will be performed at 1000mm/min.

2.9.27.2 Low

After initial reference sensor(limit switch) activation, machine will repeat measurement again, but this time at *Low* speed.

2.9.27.3 Order

User can set homing order of machine axes. Select homing order number for each axis from drop down menu.

E.g. If number is 1 for desired axis, then that axis will be homed first.

2.9.27.3.1 Direction

User can set reference direction of desired axis.

Radio button “-” references machine axis in negative direction.

Radio button “+” references machine axis in positive direction.

2.9.27.4 Switch Position

Value inserted for each axis reference switch is machine position when reference switch is activated during homing procedure.

User can quickly fill in the limit switch machine position values via *Copy Motor Limits* button.

These values are copy/pasted from Settings/Motors/Limits.

2.9.27.4.1 Move To

User can set home position of axes after homing procedure is completed. These are machine position coordinates.

E.g.: Position values are X=0 ; Y=0 and Z=50

After homing procedure of each axis is completed , X and Y axes will be positioned at 0 and Z axis at height 50mm.

2.9.28 Offsets

Here you can set sensor parameters regarding Measure procedures under Machine/Work Position/Measure Height and Machine/Tool Offset/Measure Length.

Offsets

Work Position/Measure Height

Speed Z: mm/min Low: mm/min

Size Z: mm

Switch Click Distance: mm

Tool Offset/Measure Length

Speed: mm/min Low: mm/min

Safe Height: mm

Rapid Height: mm

Sensor Position: X: Y: Z:

Switch Click Distance: mm

2.9.28.1 Work Position/Measure Height

Here you can set sensor parameters regarding Measure procedures under Machine/Work Position/Measure Height

2.9.28.1.1 Speed Z

Speed Z is speed at which machine will measure height.

2.9.28.1.2 Low

After initial first sensor activation, machine will repeat measurement again, but this time at *Low* speed.

2.9.28.1.3 Size Z

Thickness of sensor. If the tool sensor is a simple piece of copper board of thickness 1.6mm, then this value = 1.6mm

2.9.28.1.4 Switch Click Distance

Distance between the moment when limit switch is activated and when limit switch is released. Value is usually around 2-5mm.

User tests switch hysteresis value on his machine prior setting it here.

2.9.28.2 Tool Offset /Measure Length

Here you can set sensor parameters regarding Measure procedures under Machine/Tool Offset/Measure Length.

2.9.28.2.1 Speed

Speed at which machine will measure tool length.

2.9.28.2.2 Low

After initial first tool length measurement, machine will repeat measurement again, but this time at *Low* speed.

2.9.28.2.3 Safe Height

Distance to which machine Z axis ascends after tool length measurement.

2.9.28.2.4 Rapid Height

When machine is directly above the XY sensor position it will descend from Safe Height in order to measure tool offset. Rapid Height value is machine Z coordinate value, to which machine will descend with traverse speed. Remaining distance will perform at Speed value.

2.9.28.2.5 Copy Motor Limits

Copies value of Z axis motor limit.

2.9.28.2.6 Sensor Position

Machine X,Y and Z coordinates of the fixed sensor position.

2.9.28.2.7 Switch Click Distance

Distance between the moment when limit switch is activated and when limit switch is released. Value is usually around 2-5mm.

User tests switch hysteresis value on his machine prior setting it here.

2.9.29 Tool Change

Here you can set tool change related parameters.

Tool Change

Tool Change: Enable

Skip Same Tool: Enable

Spindle Check: Enable

Safe Height: mm

Position: Enable

X: Y: Z: mm

Action: Message Pause

Tool Offset

Measure Offset: None Set Offset Set Tooltable

Enable Offset: Enable

AutoReturn: Enable

2.9.29.1 Tool Change

Enable:

Enables tool change.

2.9.29.2 Skip Same Tool:

Enable:

If current tool number is the same as selected tool number, tool change will be ignored.

2.9.29.3 Spindle Check

Enable:

At the beginning of tool change procedure, spindle will be turned OFF (if it was ON prior) and when tool change procedure is completed, spindle will be turned ON.

2.9.29.4 *Safe Height*

Height to which machine Z axis ascends when tool change occurs.

2.9.29.4.1 *Copy Motor Limits*

Copies value of Z axis motor limit.

2.9.29.5 *Position*

Enable:

Enables user defined X,Y,Z position values at which manual tool change will take place.

X,Y,Z:

Machine X,Y, and Z axis position values of manual tool change.

2.9.29.6 *Action*

Message:

When tool change occurs, tool change message will be displayed, informing user of current and new tool number. Until user confirms with OK button, motion will be paused.

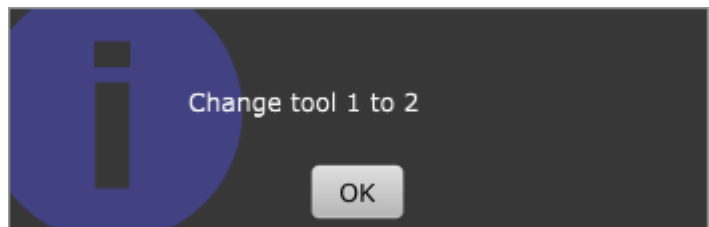

Pause:

When tool change occurs, pause will be activated.

Machine travels to tool change position and motion is paused. This way user can safely change the tool and resumes program execution.

Both enabled:

When tool change occurs, message will be displayed first, after message is confirmed, pause will be activated.

2.9.29.7 Tool Offset

Here you set tool change tool offset related parameters.

2.9.29.7.1 Measure Tool Offset

None:

After tool change, tool offset value will not be measured.

Set Tool Offset:

Tool offset value of current tool will be measured using fixed tool sensor and stored as current tool offset value.

Set Tooltable:

Tool offset value of current tool will be measured using fixed tool sensor and stored into tool table as also as current tool offset value.

2.9.29.7.2 Enable

If option *Measure Tool Offset/Set Tool Offset* or *Measure Tool Offset/Set ToolTable* is enabled, then this option need to be enabled, so that current tool offset value is set.

2.9.29.7.3 AutoReturn

When enabled, machine will automatically return to work position at which the initial tool change command was executed.

2.9.29.8 ATC

ATC

ATC: Enable

Speed For Move 1: mm/min 2: mm/min

Unload

Move In 2: X: Y: Z: mm

1: X: Y: Z: mm

Out Pin:

Not Set On Off Delay: s

Not Set On Off Delay: s

Out Pin:

Not Set On Off Delay: s

Not Set On Off Delay: s

Move Out 1: X: Y: Z: mm

2: X: Y: Z: mm

Load

Move In 2: X: Y: Z: mm

1: X: Y: Z: mm

Out Pin:

Not Set On Off Delay: s

Not Set On Off Delay: s

Out Pin:

Not Set On Off Delay: s

Not Set On Off Delay: s

Move Out 1: X: Y: Z: mm

2: X: Y: Z: mm

2.9.29.8.1 ATC

Enable:

Enables ATC options.

Speed For Move 1:

Speed value of Move In/Out 1 moves.

Speed For Move 2:

Speed value of Move In/Out 2 moves.

2.9.29.8.2 Unload

Bottom group of settings helps user to set machine motion when tool will be unloaded from spindle.

With **Move In 2,1** values, user can determine two step motion sequence which will be executed before tool is unloaded at its designated tool position. Final position where tool will be unloaded is taken from tool table.

Unload

Move In 2: X: Y: Z: mm

1: X: Y: Z: mm

With **Move Out 1,2** values, user can determine two step motion sequence which will be executed after tool is unloaded at its tool position.

Move Out 1: X: Y: Z: mm

2: X: Y: Z: mm

With **Out Pin** values, user can define controllers output pin activity during ATC procedure. Intended for external ATC equipment control (solenoid pneumatic valve control etc...).

Out Pin:

Not Set On Off Delay: s

Not Set On Off Delay: s

Out Pin:

Not Set On Off Delay: s

Not Set On Off Delay: s

Move In 2 (two steps before unload tool position):

Under this option you set *move-in* axis delta moves.

Machine axes will move **for** the distance of inserted value.

X: Delta move of X axis.

Y: Delta move of Y axis.

Z: Delta move of Z axis.

Move In 1(one step before unload tool position):

Under this option you set *move-in* axis delta moves.

Machine axes will move **for** the distance of inserted value.

X: Delta move of X axis.

Y: Delta move of Y axis.

Z: Delta move of Z axis.

After Move In 1 step is completed, machine is located at tool position and tool is ready to be unloaded!

Out Pin:

Out Pin: ---

Not Set On Off Delay: 0.0 s

Not Set On Off Delay: 0.0 s

Out Pin: ---

Not Set On Off Delay: 0.0 s

Not Set On Off Delay: 0.0 s

Out Pin: User can select controller output pin from drop down menu.

Not Set: No controller output pin will be used.

On: Selected output pin will be turned on.

Off: Selected output pin will be turned off.

Delay: Value of delay after pin is turned on/off.

Move Out 1 (first step after unload tool position):

Under this option you set *move-out* axis delta moves.

Machine axes will move **for** the distance of inserted value.

X: Delta move of X axis.

Y: Delta move of Y axis.

Z: Delta move of Z axis.

Move Out 2 (second step after unload tool position):

Under this option you set *move-out* axis delta moves.

Machine axes will move **for** the distance of inserted value.

X: Delta move of X axis.

Y: Delta move of Y axis.

Z: Delta move of Z axis.

2.9.29.8.3 Load

Bottom group of settings helps user to set machine motion when tool is being loaded to the spindle.

With **Move In 2,1** values user can determine two step motion sequence which will be executed before tool is loaded to spindle. Final position where tool will be loaded is taken from tool table.

Load

Move In 2: X: Y: Z: mm

1: X: Y: Z: mm

With **Move Out 1,2** values user can determine two step motion sequence which will be executed after tool is loaded to spindle.

Move Out 1: X: Y: Z: mm

2: X: Y: Z: mm

With **Out Pin** values, user can define controllers output pin activity during ATC procedure. Intended for external ATC equipment control (solenoid pneumatic valve control etc...).

Out Pin:

Not Set On Off Delay: s

Not Set On Off Delay: s

Out Pin:

Not Set On Off Delay: s

Not Set On Off Delay: s

Move In 2 (two steps before load tool position):

Under this option you set *move-in* axis delta moves.

Machine axes will move **for** the distance of inserted value.

X: Delta move of X axis.

Y: Delta move of Y axis.

Z: Delta move of Z axis.

Move In 1 (one step before load tool position):

Under this option you set *move-in* axis delta moves.

Machine axes will move **for** the distance of inserted value.

X: Delta move of X axis.

Y: Delta move of Y axis.

Z: Delta move of Z axis.

After Move In 1 step is completed, machine is located at tool position and tool is ready to be loaded!

Out Pin:

Out Pin: ---

Not Set On Off Delay: 0.0 s

Not Set On Off Delay: 0.0 s

Out Pin: ---

Not Set On Off Delay: 0.0 s

Not Set On Off Delay: 0.0 s

Out Pin: User can select controller output pin from drop down menu.

Not Set: No controller output pin will be used.

On: Selected output pin will be turned on.

Off: Selected output pin will be turned off.

Delay: Value of delay after pin is turned on/off.

Move Out 1 (first step after load tool position):

Under this option you set *move-out* axis delta moves.

Machine axes will move **for** the distance of inserted value.

X: Delta move of X axis.

Y: Delta move of Y axis.

Z: Delta move of Z axis.

Move Out 2 (second step after load tool position):

Under this option you set *move-out* axis delta moves.

Machine axes will move **for** the distance of inserted value.

X: Delta move of X axis.

Y: Delta move of Y axis.

Z: Delta move of Z axis.

Simple ATC configuration example:

This example will demonstrate how to configure ATC parameters for automatic tool change procedure as described below.

Initial ATC overview:

-Two tool holders are positioned in tool rack using tool clamps.

-Both tools exist in tool table: *Machine/Tools/Edit Tool Table*

-Tool 1 position: X=0, Y=-30, Z=5

-Tool 2 position: X=30, Y=-30, Z=5

-**Loading** of tool is performed in such way that tool holder is picked up by empty spindle from safe height. Spindle locks the tool holder and then machine slides out of the tool clamps in Y axis positive direction at tool position Z axis height.

-**Unloading** of tool is performed in such way that machine slides the tool holder into clamps in Y axis negative direction at tool position Z axis height. Machine then unlocks the tool holder and moves to safe height in order to pick up new tool.

-To **lock** and **unlock** tool holders, we will use controller output pin 1. Usually this pin controls external solenoid pneumatic valve.

-When ATC will be at the stage of locking or unlocking the tool holders, short **delay** will be added for safety reasons.

ATC

ATC: Enable

Speed For Move 1: mm/min 2: mm/min

Unload

Move In 2: X: Y: Z: mm

1: X: Y: Z: mm

Out Pin:

Not Set On Off Delay: s

Not Set On Off Delay: s

Out Pin:

Not Set On Off Delay: s

Not Set On Off Delay: s

Move Out 1: X: Y: Z: mm

2: X: Y: Z: mm

Load

Move In 2: X: Y: Z: mm

1: X: Y: Z: mm

Out Pin:

Not Set On Off Delay: s

Not Set On Off Delay: s

Out Pin:

Not Set On Off Delay: s

Not Set On Off Delay: s

Move Out 1: X: Y: Z: mm

2: X: Y: Z: mm

2.9.30 Gantry Square

Here you set parameters related to gantry squaring procedure.

Gantry Square

Speed: mm/min

Axis: Direction: - +

Move U: mm V: mm

PLEASE NOTE: Prior using gantry square procedure, user needs to configure master and slave motor outputs and their corresponding limit switch inputs.

2.9.30.1 Speed

Speed value of gantry squaring procedure.

2.9.30.2 Axis

Axis name that will be squared. This is the axis that uses master and slave motors.

2.9.30.3 Direction

Motor direction of master and slave motors during the gantry squaring procedure.

2.9.30.4 Move U

Retract distance for which axis will move once its corresponding switch is activated.

2.9.30.5 Move V

Retract distance for which axis will move once its corresponding switch is activated.

2.9.31 Motor Drivers

Group of settings for integrated motor drivers of Mk3DRV motion controller.

Please note that these settings are enabled only when Mk3DRV controller is connected and selected as Primary controller under Settings/Connection

2.9.31.1 Microstepping

User can choose between 1/1 step mode (full step) and 1/32 step mode (32 micro steps).

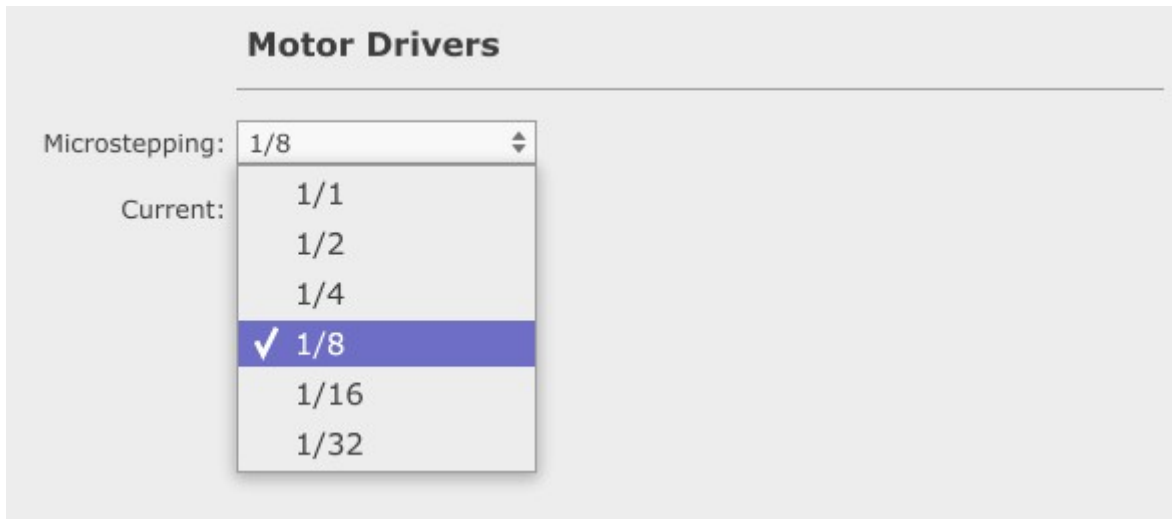

2.9.31.2 Current

User can set motor drivers current value using "+" or "-" buttons or typing current value directly into "Current" window.

Minimal recommended value is 0.5A, maximal value is 2.5A.

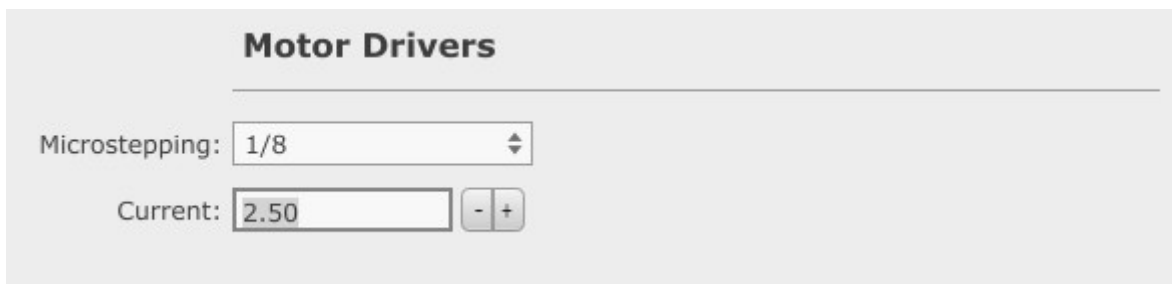

3 G-code

G-code is a programming language that is used by CNC machines. Motion controller interprets the g-code commands and arranges series of appropriate actions that result in coordinated machine motion.

G-code commands can be divided into multiple groups which differ from one another based on functionality and intended use.

Single G-code line, aka block, can include commands for machine motion, program and data manipulation, or peripheral control.

G-code will be described much more in detail in g-code reference manual.

3.1 Obtaining G-code

Simple g-code programs (i.e. simple toolpaths) can be easily written manually. For this purpose we recommend that users get at least familiar with g-code. Get to know groups of g-code commands, syntax, format and programming guidelines. Even if user does not have an intention of manually writing his g-code programs, it can be in great help when debugging and understanding program and machine behaviour.

It is also possible to use one of TNG Import program features such as *Import DXF* and *Import Gerber* . Meaning, user can directly import his DXF (CAD file) or Gerber(PCB CAD file) files into PlanetCNC TNG sw. PlanetCNC TNG will auto-generate g-code for imported file.

For more info on these program features please read chapters 2.4.5. and 2.4.7.

Another option would be to use third party CAM software. In this case part is designed in CAD(Computer-aided design) software. CAD file is imported into CAM (Computer-aided manufacturing) software. In CAM sw you consider tool radius offsets, tool change, feed speeds, pocket milling, cutouts etc... CAM software then generates toolpath based on the CAD drawing. Using post-processor, CAM software then generates g-code program.

4 Parameters

PlanetCNC TNG G-code language supports parameters. Through parameters we can query machine state and behaviour. Parameters are divided into groups based on their intended use, scope, mode and persistence.

Intended use:

Settings parameters carry information on how our machine is configured. This includes motion and motor limits, motor step per unit values, output pin configuration etc...

Interpreter parameters reflect machine state as per executed g-code program. So all commands from g-code program will influence interpreter parameters values, such as Spindle on/off state, spindle RPM, motion mode, position values etc...

It is important not to confuse these parameters with hardware parameters which reflect actual real-time machine status.

Hardware parameters give machine values in real time. They reflect actual values of motor position, output and input pin status etc...

User parameters are parameters that are created by user. Usually for the needs of script programs.

Scope:

Parameters can be **numbered** or **named**. **Named** parameters are further divided into *Named local* and *Named global* parameters.

Mode:

Some parameters are **read-only** while others can be assigned to new value(**read/write**).

Persistence:

Volatile parameters lose their values once you exit PlanetCNC TNG software, **Persistent** parameters will keep their values even when you close TNG software.

Persistent parameters are located in *Parameters.txt* file in PlanetCNC TNG profile folder.

Parameters will be described much more in detail in PlanetCNC G-code reference manual.

5 Scripts

PlanetCNC TNG software supports use of scripts. Scripts are basically g-code programs that are executed when called. For example, some program features, such as homing, tool change are implemented as scripts. All M g-codes, such as M3, M7, M8 are also implemented as scripts.

The main purpose of scripts is to offer user an option of changing the default behaviour of program features or g-code. In most cases this comes very useful when user needs to obtain custom machine motion sequence or special program/parameter manipulation.

Script files (using suffix .gcode) are located in Scripts folder of corresponding profile in PlanetCNC TNG installation folder.

5.1 Accessing script files

There are multiple ways on how to access specific script file:

1. Via Settings: In PlanetCNC TNG software click: File/Settings/Program Options/Scripts
Select command from drop down menu of corresponding program feature or M-code and click *Edit Script* button.
Script file of selected command will open in your default text editor.
2. Probably the fastest way of accessing script files is using combination of PC keyboard keys and Left mouse button.
All you need to do is press combination of Ctrl + Alt keyboard keys and then using left mouse button to click on desired program feature (this can be Machine menu item or toolbar button).
3. Script file of selected feature will open in your default text editor.
4. Locate PlanetCNC TNG software installation folder and open Profiles folder.
Locate Scripts folder and open desired script file. If script file is not present in the Scripts folder of your PlanetCNC TNG profile, then perform procedure described in point 1. of this chapter. Also note, some program features and g-code are not script-able.

5.2 Example of script file customization

Scripts can be short programs that add short delay on spindle ramp up or they can be longer more complex programs such as automatic tool change procedure.

Customization is in other words editing scripts g-code.

5.2.1 Customization of “Move/To Zero” program feature script code

Default script g-code for *Move/To Zero* program feature initiates motion for all machine axes from their current position to absolute zero position of machine.

Because moving all axes simultaneously towards zero position is somewhat dangerous, we would like to move our Z axis first, before we start to move X and Y axis.

Safest height for Z axis would be its max position value. We can “borrow” this value from Settings/Motion/Range → *Range+* value for Axis Z. This value is saved in parameter *_motionrange_zp*.

So new motion sequence would be: Move Z axis to its safe height first, then move axes X and Y to its zero position and last move Z axis to zero.

1. We access “Move/To Zero” script file using one of listed options described in chapter 3.1
2. Once script file is opened in our default text editor we can add/remove lines of g-code that will change its original default behavior.
3. Original script code looks like this:

```
M70
G90 G15
G00 X0 Y0 Z0 A0 B0 C0 U0 V0 W0
M72
```

We edit this g-code in such way, so that axis Z is moved first to its safe height, then all other axes move to zero, and finally Z axis is moved to zero:

```
M70
G90 G15
G00 Z[#<_motionrange_zp>]
G00 X0 Y0 A0 B0 C0 U0 V0 W0
G00 Z0
M72
```

5.2.2 Customization of “M8” g-code script code

Default script g-code for M8(flood) g-code activates its corresponding output pin in order to turn on the coolant.

Let's say we would like to add a short delay after we turn ON coolant pump. This is useful when we need to provide a steady stream of coolant fluid before we begin with milling.

So new script behaviour will activate corresponding output of controller, wait for 5 seconds and then continue with main program execution.

1. We access “M8” script file using one of listed options described in chapter 3.1
2. Once script file is opened in our default text editor we can add/remove lines of g-code that will change its original default behavior.
3. Original script code looks like this:

```
M8
```

We will add a G4 g-code for *Dwell* which will delay main program execution for 5 seconds.

```
M8
```

```
G04 P5
```

Table of Contents

Disclaimer.....	2
1 Introduction.....	3
1.1 Overview.....	3
1.2 Features and specifications:.....	4
1.3 System Requirements.....	5
2 Software.....	6
2.1 Overview.....	6
2.2 Installation.....	7
2.2.1 Software installation on Windows.....	8
2.2.3 Software installation on Linux.....	12
2.3 Main Window.....	28
2.3.1 Menu bar.....	29
2.3.1.1 Buttons for panel display manipulation.....	29
2.3.2 Toolbars.....	33
2.3.2.1 Top toolbar:.....	33
2.3.2.2 Left toolbar:.....	34
2.3.2.3 Toolbar additional features.....	35
2.3.3 Position panel.....	37
2.3.3.1 Work.....	37
2.3.3.2 Machine.....	39
2.3.3.3 Motors.....	41
2.3.3.4 GCode.....	41
2.3.4 Speed Panel.....	42
2.3.4.1 Feed speed display:.....	42
2.3.4.2 Spindle speed display:.....	44
2.3.5 State panel.....	45
2.3.5.1 Gcode state tab.....	45
2.3.5.2 IO state tab.....	46
2.3.5.3 User state tabs.....	50
2.3.6 Jogging Panel.....	51
2.3.7 3D program visualization display.....	53
2.3.8 G-Code panel.....	54
2.3.8.1 Vertical Slider.....	54
2.3.8.2 Position Slider.....	54
2.3.8.3 Additional G-code panel options.....	55
2.3.9 Utilities panel.....	56
2.3.9.1 Output tab.....	56
2.3.9.2 Edit tab.....	58
2.3.9.3 Log tab.....	61
2.3.9.4 Camera tab.....	63
2.3.10 Manual data input (MDI) window.....	67
2.3.11 Indication Light.....	69
2.3.11.1 Indication light colour description:.....	69
2.4 File menu.....	70
2.4.1 Close.....	71

2.4.2	Open.....	71
2.4.3	Recent files.....	71
2.4.4	Import G-code.....	72
2.4.5	Import DXF.....	73
2.4.6	Import PLT, HPGL.....	73
2.4.6.1	Units.....	74
2.4.6.2	Scale.....	74
2.4.6.3	Origin.....	75
2.4.6.4	Loops.....	79
2.4.6.5	Interpolate.....	79
2.4.6.6	Sort.....	79
2.4.6.7	Feed Speed.....	79
2.4.6.8	Plunge Speed.....	79
2.4.6.9	Tool change and Offset.....	79
2.4.6.10	Outputs.....	80
2.4.6.11	<i>Import DXF</i> function library:.....	80
2.4.6.12	Mode.....	82
2.4.6.13	Height.....	83
2.4.6.14	Tabs.....	86
2.4.6.15	Tangent Knife.....	87
2.4.6.16	Bottom - Off.....	87
2.4.6.17	Top Off.....	88
2.4.6.18	Top On.....	89
2.4.6.19	Bottom On.....	89
2.4.7	Import Gerber.....	90
2.4.7.1	Feed Speed.....	91
2.4.7.2	Plunge Speed.....	91
2.4.7.3	Safe Height.....	91
2.4.7.4	Start Height.....	91
2.4.7.5	Tool change.....	91
2.4.7.6	Offset.....	91
2.4.7.7	Mirror.....	92
2.4.7.8	Size X.....	93
2.4.7.9	Size Y.....	93
2.4.7.10	Outputs.....	94
2.4.7.11	Use.....	95
2.4.7.12	Mark Pads.....	96
2.4.7.13	Cutting Path.....	97
2.4.7.14	Drill Pads.....	98
2.4.7.15	Clear Copper.....	99
2.4.7.16	Enable.....	99
2.4.7.17	Outline.....	101
2.4.7.18	Border.....	102
2.4.7.19	Cute Height.....	104
2.4.7.20	Pause.....	104
2.4.7.21	Tool.....	104
2.4.7.22	Diameter.....	104
2.4.8	Import NC drill.....	105
2.4.8.1	Feed Speed.....	106

2.4.8.2	Plunge Speed.....	106
2.4.8.3	Safe Height.....	106
2.4.8.4	Start Height.....	106
2.4.8.5	Cut Height.....	106
2.4.8.6	Tool change.....	106
2.4.8.7	Offset.....	106
2.4.8.8	Mirror.....	107
2.4.8.9	Size X.....	107
2.4.8.10	Size Y.....	107
2.4.8.11	Units.....	107
2.4.8.12	Format.....	107
2.4.8.13	Leading/Trailing Zeroes.....	107
2.4.9	Import CSV.....	108
2.4.10	Import Image.....	108
2.4.11	Import Python Script.....	109
2.4.12	Generate.....	109
2.4.13	Export G-code.....	110
2.4.14	Export DXF.....	110
2.4.15	Export CSV.....	110
2.4.16	Run Python Script.....	110
2.4.17	Settings.....	111
2.4.18	Import Settings.....	111
2.4.19	Export Settings.....	111
2.4.20	Import Profile.....	112
2.4.21	Export Profile.....	113
2.4.22	Language.....	114
2.4.23	Exit.....	114
2.5	View menu.....	115
2.5.1	Top view.....	116
2.5.2	Side View.....	117
2.5.3	Front View.....	117
2.5.4	Perspective view.....	118
2.5.5	Zoom In.....	118
2.5.6	Zoom Out.....	118
2.5.7	Zoom Position.....	118
2.5.8	Zoom Part.....	118
2.5.9	Follow Position.....	118
2.5.10	Center Zero.....	118
2.5.11	Show.....	119
2.5.11.1	Show grid.....	119
2.5.11.2	Show Axes Lines.....	119
2.5.11.3	Show Axes Center.....	119
2.5.11.4	Show Limits.....	120
2.5.11.5	Show Extents.....	120
2.5.11.6	Show Toolpath History.....	120
2.5.11.7	Show Gauges.....	120
2.5.11.8	Show Hover.....	120
2.5.11.9	Show Completed.....	120
2.5.11.10	Show Depthtest.....	121

2.5.11.11 Show Multisample.....	122
2.5.11.12 Show Objects.....	122
2.5.12 Panel.....	123
2.5.13 Reset Windows.....	123
2.6 Program menu.....	124
2.6.1 Redraw.....	125
2.6.2 Edit.....	125
2.6.3 Lines.....	127
2.6.3.1 Next.....	127
2.6.3.2 Next Page.....	127
2.6.3.3 Previous.....	127
2.6.3.4 Previous Page.....	127
2.6.3.5 Forward.....	127
2.6.3.6 Reverse.....	127
2.6.3.7 Find.....	128
2.6.3.8 Find Next.....	128
2.6.3.9 Find Comment.....	128
2.6.3.10 Find Tool-change.....	128
2.6.3.11 Find Spindle.....	128
2.6.3.12 Optional Block Enabled.....	128
2.6.4 MDI.....	129
2.6.4.1 Select.....	129
2.6.4.2 Show history.....	129
2.6.4.3 Clear history.....	129
2.6.5 Bookmarks.....	130
2.6.5.1 Select Next.....	130
2.6.5.2 Select previous.....	130
2.6.5.3 Select All.....	130
2.6.5.4 Toggle.....	130
2.6.5.5 Clear.....	130
2.6.5.6 Set.....	131
2.6.6 Transformation.....	132
2.6.6.1 Disable.....	132
2.6.6.2 Clear.....	132
2.6.6.3 Redraw.....	132
2.6.7 Shift.....	134
2.6.7.1 X,Y,Z:.....	134
2.6.7.2 Copy From.....	134
2.6.8 Scale.....	136
2.6.8.1 X,Y,Z:.....	136
2.6.9 Rotate.....	136
2.6.10 Mirror.....	137
2.6.11 Points.....	138
2.6.11.1 Source.....	139
2.6.11.2 Destination.....	140
2.6.12 Clear.....	142
2.6.13 Undo.....	142
2.6.14 Warp.....	142
2.6.14.1 Resolution.....	143

2.6.14.2 Enable/Disable.....	143
2.6.14.3 Clear.....	143
2.6.14.4 From File.....	143
2.6.14.5 From Points.....	143
2.6.15 Copy XYZ → UVW.....	145
2.6.16 Copy UVW → XYZ.....	145
2.6.17 Swap XYZ ↔ UVW.....	145
2.6.18 Copy to Clipboard.....	145
2.6.19 Paste from Clipboard.....	145
2.7 Machine Menu.....	146
2.7.1 Emergency stop.....	147
2.7.2 Start.....	147
2.7.3 Stop.....	147
2.7.4 Pause.....	147
2.7.5 Start.....	148
2.7.5.1 Start From Selected Line.....	149
2.7.5.2 Start From Bookmark To Bookmark.....	149
2.7.5.3 Beginning to Bookmark.....	149
2.7.5.4 Start From Bookmark to End.....	149
2.7.5.5 Start Loop.....	149
2.7.6 Overrides.....	150
2.7.6.1 Speed Override Enable.....	151
2.7.6.2 Traverse.....	151
2.7.6.3 Feed.....	152
2.7.6.4 Spindle Override Enable.....	153
2.7.6.5 Spindle.....	153
2.7.6.6 Pause Enable.....	154
2.7.6.7 Pause optional.....	154
2.7.6.8 Single Step.....	154
2.7.7 Mist.....	155
2.7.8 Flood.....	155
2.7.9 Spindle.....	155
2.7.10 Output.....	156
2.7.10.1 Output 1-8:.....	157
2.7.11 Motors, Limits, Probe.....	158
2.7.11.1 Motors Enable.....	159
2.7.11.2 Soft Limits Enable.....	159
2.7.11.3 Hard Limits Enable.....	159
2.7.11.4 Probe Trigger.....	159
2.7.12 Tools.....	160
2.7.12.1 Current Active Tool.....	161
2.7.12.2 Change.....	161
2.7.12.3 Select.....	162
2.7.12.4 Edit Tool Table.....	163
2.7.13 Move.....	170
2.7.13.1 To Zero.....	171
2.7.13.2 To.....	171
2.7.13.3 Axis to Zero.....	173
2.7.13.4 To G28.....	173

2.7.13.5 To G30.....	173
2.7.13.6 To Selected Line.....	173
2.7.13.7 To Selected Line XY.....	174
2.7.13.8 Position to Camera.....	174
2.7.13.9 Camera To Position.....	174
2.7.13.10 Camera To Selected Line XY.....	174
2.7.14 Machine Position.....	175
2.7.14.1 To Zero.....	176
2.7.14.2 To.....	176
2.7.14.3 Axis To Zero.....	178
2.7.14.4 Unwind ABC.....	178
2.7.14.5 As G28.....	179
2.7.14.6 As G30.....	179
2.7.15 Work Position.....	180
2.7.15.1 To Zero.....	181
2.7.15.2 To.....	181
2.7.15.3 Axis To Zero.....	183
2.7.15.4 Measure Height.....	184
2.7.15.5 Offset.....	185
2.7.15.6 Selected Line.....	187
2.7.15.7 Selected Line XY.....	187
2.7.15.8 Camera XY.....	187
2.7.16 Coordinate System.....	188
2.7.16.1 Current Coordinate System.....	189
2.7.16.2 Select.....	189
2.7.16.3 To Zero.....	189
2.7.16.4 To.....	190
2.7.16.5 Axis To Zero.....	191
2.7.16.6 Measure Height.....	191
2.7.16.7 Offset.....	192
2.7.17 Tool Offset.....	195
2.7.17.1 Enabled.....	196
2.7.17.2 To Zero.....	196
2.7.17.3 To.....	197
2.7.17.4 Axis to Zero.....	198
2.7.17.5 Measure Length.....	199
2.7.17.6 From Tool Table.....	199
2.7.18 Home.....	200
2.7.19 Measure.....	201
2.7.19.1 Inside Corner.....	202
2.7.19.2 Outside Corner.....	204
2.7.19.3 Hole.....	206
2.7.19.4 Protrusion.....	207
2.7.19.5 Slot.....	212
2.7.19.6 Tab.....	213
2.7.19.7 Axis.....	215
2.7.19.8 Angle.....	217
2.7.19.9 Surface Height.....	219
2.7.19.10 Surface Angle.....	220

2.7.19.11	Surface.....	221
2.7.19.12	Gantry Square.....	221
2.7.20	Points.....	222
2.7.20.1	Count.....	223
2.7.20.2	Load.....	223
2.7.20.3	Save.....	223
2.7.20.4	Save STL.....	223
2.7.20.5	Save DXF.....	223
2.7.20.6	To Output.....	223
2.7.20.7	Clear.....	223
2.7.20.8	Add from Position.....	223
2.7.20.9	Add from Camera.....	223
2.7.21	Camera.....	224
2.7.21.1	Show.....	225
	Set Offset.....	231
2.7.22	User Commands.....	233
2.7.23	Controller.....	235
2.7.23.1	Reconnect.....	236
2.7.23.2	Reset.....	236
2.7.23.3	Firmware Update.....	236
2.7.23.4	Advanced.....	236
2.8	Help.....	238
2.8.1	User Manual.....	238
2.8.2	G-code Manual.....	238
2.8.3	License management.....	239
2.8.3.1	Licenses.....	239
2.8.3.2	Activation Code Generator.....	241
2.8.4	Check For Updates.....	242
2.8.5	Show Log.....	242
2.8.6	About.....	242
2.9	Settings.....	243
2.9.1	General.....	244
2.9.1.1	Description.....	245
2.9.1.2	Units.....	245
2.9.1.3	Machine type.....	245
2.9.1.4	Notes.....	246
2.9.1.5	Password.....	246
2.9.1.6	Check For Updates.....	246
2.9.2	Connection.....	247
2.9.2.1	Connection.....	248
2.9.2.2	Adapter IP.....	253
2.9.2.3	Primary Controller.....	253
2.9.3	User Interface.....	254
2.9.3.1	Colors.....	255
2.9.3.2	Properties.....	257
2.9.3.3	Dialogs.....	261
2.9.3.4	Commands.....	264
2.9.4	Menu.....	265
2.9.4.1	Colors.....	265

2.9.4.2 Properties.....	266
2.9.5 Toolbars.....	267
2.9.5.1 Colors.....	267
2.9.5.2 Properties:.....	270
2.9.6 Position.....	272
2.9.6.1 Colors.....	273
2.9.6.2 Properties.....	275
2.9.6.3 Commands.....	277
2.9.7 Speed.....	278
2.9.7.1 Colors.....	279
2.9.7.2 Speed.....	282
2.9.7.3 Spindle.....	285
2.9.8 State.....	287
2.9.8.1 Colors.....	287
2.9.9 Jog.....	290
2.9.9.1 Colors.....	290
2.9.9.2 Properties.....	291
2.9.10 3D.....	294
2.9.10.1 Colors.....	294
2.9.10.2 Properties.....	296
2.9.10.3 User Interface/Geometry.....	307
2.9.10.4 ABC:.....	315
2.9.10.5 UVW:.....	315
2.9.11 Gcode.....	316
2.9.11.1 Colors.....	317
2.9.11.2 Properties.....	318
2.9.11.3 MDI.....	319
2.9.12 Utilities.....	322
2.9.12.1 Colors.....	322
2.9.12.2 Panels.....	325
2.9.13 Shortcuts.....	326
2.9.13.1 Action.....	327
2.9.13.2 Code.....	327
2.9.13.3 MDI.....	328
2.9.13.4 Pin.....	328
2.9.14 Motors.....	330
2.9.14.1 Step Width.....	331
2.9.14.2 Enable Pin.....	331
2.9.14.3 Motor.....	332
2.9.14.4 Steps Per Unit.....	334
2.9.14.5 Speed.....	335
2.9.14.6 Acceleration.....	336
2.9.14.7 Backlash.....	337
2.9.14.8 Limits.....	339
2.9.14.9 Limit Switches.....	340
2.9.14.10 Invert and Estop.....	343
2.9.15 Motion.....	344
2.9.15.1 Maximum Speed:.....	344
2.9.15.2 Max Acceleration:.....	344

2.9.15.3	Max Deceleration:.....	344
2.9.15.4	Motion XYZ, ABC, UVW.....	345
2.9.15.5	Blend.....	346
2.9.15.6	Advanced.....	353
2.9.16	Jogging.....	354
2.9.16.1	Default Speed.....	355
2.9.16.2	Default Step.....	355
2.9.16.3	Default Round.....	356
2.9.16.4	Probe Lock.....	356
2.9.16.5	Jogging Keyboard.....	358
2.9.16.6	Handwheel.....	359
2.9.17	Input/Output.....	363
2.9.17.1	E-Stop Pin.....	364
2.9.17.2	Error Pin.....	364
2.9.17.3	Input Pin 1-8.....	364
2.9.17.4	Output Pin 1-8.....	364
2.9.18	Spindle.....	365
2.9.18.1	Output Pin – CW.....	366
2.9.18.2	Output Pin – CCW.....	366
2.9.18.3	Output Pin – Speed.....	366
2.9.18.4	Start Delay.....	366
2.9.18.5	Stop Delay.....	366
2.9.18.6	Frequency.....	367
2.9.18.7	PWM.....	368
2.9.18.8	RC.....	368
2.9.18.9	Encoder.....	369
2.9.18.10	Synchronisation.....	371
2.9.19	Coolant.....	373
2.9.19.1	Mist.....	373
2.9.19.2	Flood.....	373
2.9.20	I2C, TX, Ext.....	374
2.9.20.1	I2C.....	374
2.9.20.2	TX.....	374
2.9.20.3	Encoder.....	375
2.9.20.4	Ext.....	375
2.9.21	THC.....	376
2.9.21.1	Axis.....	376
2.9.21.2	Dec Pin.....	377
2.9.21.3	Inc Pin.....	377
2.9.21.4	OK Pin.....	377
2.9.21.5	Range Min.....	377
2.9.21.6	Range Max.....	377
2.9.21.7	Speed.....	377
2.9.22	Program Options.....	378
2.9.22.1	Mode.....	379
2.9.22.2	Speed.....	380
2.9.22.3	Transformation.....	380
2.9.23	Paths.....	381
2.9.23.1	G-Code folders.....	381

2.9.23.2 Python.....	381
2.9.24 Scripts.....	382
2.9.25 Events.....	393
2.9.25.1 Start From Line.....	394
2.9.25.2 Estop.....	394
2.9.25.3 On Start.....	395
2.9.25.4 On End.....	395
2.9.25.5 On Stop.....	395
2.9.26 Probe & Measure.....	396
2.9.26.1 Probe 1 Pin.....	396
2.9.26.2 Probe 2 Pin.....	396
2.9.26.3 Probe speed.....	396
2.9.26.4 Low.....	396
2.9.26.5 Probe Size Z.....	397
2.9.26.6 Probe Size XY.....	397
2.9.26.7 Safe Height.....	397
2.9.26.8 Probe Estop.....	397
2.9.27 Home.....	398
2.9.27.1 Speed.....	399
2.9.27.2 Low.....	399
2.9.27.3 Order.....	399
2.9.27.4 Switch Position.....	399
2.9.28 Offsets.....	400
2.9.28.1 Work Position/Measure Height.....	400
2.9.28.2 Tool Offset /Measure Length.....	401
2.9.29 Tool Change.....	402
2.9.29.1 Tool Change.....	402
2.9.29.2 Skip Same Tool:.....	402
2.9.29.3 Spindle Check.....	402
2.9.29.4 Safe Height.....	403
2.9.29.5 Position.....	403
2.9.29.6 Action.....	403
2.9.29.7 Tool Offset.....	404
2.9.29.8 ATC.....	405
2.9.30 Gantry Square.....	414
2.9.30.1 Speed.....	414
2.9.30.2 Axis.....	414
2.9.30.3 Direction.....	414
2.9.30.4 Move U.....	414
2.9.30.5 Move V.....	414
2.9.31 Motor Drivers.....	415
2.9.31.1 Microstepping.....	415
2.9.31.2 Current.....	415
3 G-code.....	416
3.1 Obtaining G-code.....	416
4 Parameters.....	417
5 Scripts.....	418
5.1 Accessing script files.....	418
5.2 Example of script file customization.....	419

5.2.1 Customization of “Move/To Zero” program feature script code.....	419
5.2.2 Customization of “M8” g-code script code.....	420